



MONITOUCH V8 series

Introductory Manual



Preface

Congratulations on purchasing the drawing/editing software (V-SFT-5) for the MONITOUCH V series.
For your understanding, please read this manual and related manuals thoroughly.

Notes:

1. The copyright of the software is possessed by Hakko Electronics Co., Ltd.
2. Reproduction of the contents of the software and this manual, in whole or in part, without permission of Hakko Electronics Co., Ltd. is prohibited.
3. The specifications of the software and the information in this manual are subject to change without prior notice.
4. If the specifications of the software do not correspond with the contents of this manual, the software specifications have priority.
5. No liability is assumed by Hakko Electronics Co., Ltd. with respect to the influence brought by the result of using the software or this manual.
6. You may use this software on a single central processing unit.

About Trademarks

- Windows, Word and Excel are registered trademarks of Microsoft Corporation in the United States and other countries.
- All other company names or product names are trademarks or registered trademarks of their respective holders.
- The names of the products contained herein are trademarks or registered trademarks of their respective manufacturers.

About Manuals

This manual describes the basic operating procedures of the drawing/editing software “V-SFT” version 5 for the MONITOUCH V8 series, intended for users who use this software for the first time.

The following manuals are available for the MONITOUCH V8 series:

Manual Name	Reference No.	Contents
V8 Series Reference Manual	1055NEx	Functions of the MONITOUCH V8 series are explained in detail.
V Series Macro Reference	1056NEx	An overview of macros of V-SFT version 5 as well as macro editor operations and macro command descriptions are explained in detail.
V8 Series Introductory Manual (This manual)	1057NEx	An overview of the MONITOUCH V8 series as well as basic operating procedures of the configuration software are explained in detail.
V8 Series Operation Manual	1058NEx	The information related to the operations of the V-SFT version 5, such as software composition, editing procedure or limitations, is explained in detail.
V8 Series Reference Additional Functions	1060NEx	The functions that are added from the V-SFT version 5.1.0.0 to the MONITOUCH V8 series are explained in detail.
V8 Series Hardware Specifications	2016NEx	Hardware specifications and handling procedures of the MONITOUCH V8 series are explained.
V806 Series Hardware Specifications	2017NEx	Hardware specifications and handling procedures of the MONITOUCH V806 series are explained.
V815 Hardware Specifications	2018NEx	Hardware specifications and handling procedures of the MONITOUCH V815 are explained.
V808CH Hardware Specifications	2019NEx	Hardware specifications and handling procedures of the MONITOUCH V808CH are explained.
V8 Series Connection Manual	2201NEx	Connections with respective devices and wiring diagrams of the MONITOUCH V8 series are explained.
V Series DLL Function Specifications	1059NEx	An overview and contents of DLL files used for Ethernet (HKEtn20.DLL) and CF card (VCFacs.DLL) are explained in detail.

V8 Series Models

The following MONITOUCH V8 series models are available:

Generic Name	Series	Model	V8 Classification
V series	V8 series	V815iX	V8i or V8i series
		V812iS	V8i or V8i series
		V812S	V8
		V810iS	V8i or V8i series
		V810S	V8
		V810iT	V8i or V8i series
		V810T	V8
		V810iC	V8i or V8i series
		V810C	V8
		V808iS	V8i or V8i series
		V808S	V8
		V808iC	V8i or V8i series
		V808C	V8
		V806iT	V8i or V806i series
		V806iC	
		V806iM	
		V806T	V8 or V806 series
		V806C	
		V806M	
		V808iCH	
V808CH			

Please note that the V series model names are used as listed above in the manuals.

Notes on Safe Usage of MONITOUCH

In this manual, you will find various notes categorized under the following levels with the signal words "DANGER," and "CAUTION".



DANGER

Indicates an imminently hazardous situation which, if not avoided, will result in death or serious injury.



CAUTION

Indicates a potentially hazardous situation which, if not avoided, may result in minor or moderate injury and could cause property damage.

Note that there is a possibility that the item listed with CAUTION may have serious ramifications.



DANGER

- Never use the output function of MONITOUCH for operations that may threaten human life or damage the system, such as switches used in case of emergency. Please design the system so that it can cope with the malfunctions of a touch switch. A malfunction of a touch switch will result in machine accident or damage.
- Turn off the power supply when you set up the unit, connect new cables or perform maintenance or inspections. Otherwise, electrical shock or damage may occur.
- Never touch any terminals while the power is on. Otherwise, electric shock may occur.
- You must put a cover on the terminals on the unit when you turn the power on and operate the unit. Without the terminal cover in place, an electric shock may occur.
- The liquid crystal in the LCD panel is a hazardous substance. If the LCD panel is damaged, do not ingest the leaked liquid crystal. If the liquid crystal spills on skin or clothing, use soap and wash off thoroughly.
- For MONITOUCH using a lithium battery, never disassemble, recharge, deform by pressure, short-circuit, reverse the polarity of the battery, or dispose of the battery in fire. Failure to follow these conditions will lead to explosion or fire.
- For MONITOUCH using a lithium battery, never use a battery that is deformed, leaks, or shows any other signs of abnormality. Failure to follow these conditions will lead to explosion or fire.
- The power lamp flashes when the backlight is at the end of life or is faulty. However, the switches on the screen are operable at this time. Do not touch the screen when the screen becomes dark and the power lamp flashes. Otherwise, a malfunction may occur and result in machine accident or damage.

 **CAUTION**

- Check the appearance of the unit when it is unpacked. Do not use the unit if any damage or deformation is found. Failure to do so may lead to fire, damage, or malfunction.
- For use in a facility or for a system related to nuclear energy, aerospace, medical, traffic equipment, or mobile installations, please consult your local distributor.
- Operate (or store) MONITOUCH under the conditions indicated in this manual and related manuals. Failure to do so could cause fire, malfunction, physical damage, or deterioration.
- Understand the following environmental limits for use and storage of MONITOUCH. Otherwise, fire or damage to the unit may result.
 - Avoid locations where there is a possibility that water, corrosive gas, flammable gas, solvents, grinding fluids or cutting oil can come into contact with the unit.
 - Avoid high temperature, high humidity, and outside weather conditions, such as wind, rain or direct sunlight.
 - Avoid locations where excessive dust, salt, and metallic particles are present.
 - Avoid installing the unit in a location where vibration or physical shock may be transmitted.
- Equipment must be correctly mounted so that the main terminal of MONITOUCH cannot be touched inadvertently. Otherwise, an accident or electric shock may occur.
- Tighten the fixtures of the MONITOUCH with a torque in the specified range. Excessive tightening may distort the panel surface. Loose tightening may cause MONITOUCH to come off, malfunction, or be short-circuited.
- Check periodically that terminal screws on the power supply terminal block and fixtures are firmly tightened. Loosened screws may result in fire or malfunction.
- Tighten terminal screws on the power supply terminal block equally to a torque of 0.5 N•m. Improper tightening of screws may result in fire, malfunction, or other trouble.
- MONITOUCH has a glass screen. Do not drop or give physical shock to the unit. Otherwise, the screen may be damaged.
- Connect the cables correctly to the terminals of MONITOUCH in accordance with the specified voltage and wattage. Over-voltage, over-wattage, or incorrect cable connection could cause fire, malfunction or damage to the unit.
- Be sure to establish a ground of MONITOUCH. The FG terminal must be used exclusively for the unit with the level of grounding resistance less than 100Ω. Otherwise, electric shock or fire may occur.
- Prevent any conductive particles from entering into MONITOUCH. Failure to do so may lead to fire, damage or malfunction.
- After wiring is finished, remove the paper used as a dust cover before starting to operate MONITOUCH. Operation with the cover attached may result in accident, fire, malfunction, or other trouble.
- Do not attempt to repair MONITOUCH at your site. Ask Hakko Electronics or the designated contractor for repair.
- Do not disassemble or modify MONITOUCH. Otherwise, a malfunction may occur.
- Hakko Electronics Co., Ltd. is not responsible for any damages resulting from repair, overhaul or modification of MONITOUCH that was performed by an unauthorized person.
- Do not use a sharp-pointed tool when pressing a touch switch. Doing so may damage the screen.
- Only experts are authorized to set up the unit, connect the cables, or perform maintenance and inspections.
- For MONITOUCH using a lithium battery, handle the battery with care. The combustible materials such as lithium or organic solvent contained in the battery may generate heat, explode, or catch fire, resulting in personal injury or fire. Read related manuals carefully and handle the lithium battery correctly as instructed.
- When using a MONITOUCH that has an analog switch resolution with resistance film, do not press two or more points on the screen at the same time. If two or more positions are pressed at the same time, the switch located between the pressed positions will activate.
- Take safety precautions during such operations as setting change during running, forced output, start, and stop. Any misoperation may cause unexpected machine motions, resulting in machine accident or damage.
- In facilities where a failure of MONITOUCH could lead to accident threatening human life or other serious damage, be sure that the facilities are equipped with adequate safeguards.
- At the time of disposal, MONITOUCH must be treated as industrial waste.
- Before touching MONITOUCH, discharge static electricity from your body by touching grounded metal. Excessive static electricity may cause malfunction or other trouble.
- The LED lamp on the CF card interface cover illuminates in red when the power is supplied to the CF card. Never remove the CF card or turn off the power of MONITOUCH while the LED lamp is lit. Doing so may destroy the data on the CF card. Check that the LED lamp has gone off before removing the CF card or turning off the power of MONITOUCH.

[General Notes]

- Never bundle control cables nor input/output cables with high-voltage and large-current carrying cables such as power supply cables. Keep these cables at least 200 mm away from high-voltage and large-current carrying cables. Otherwise, malfunction may occur due to noise.
- When using MONITOUCH in an environment where a source of high-frequency noise is present, it is recommended that the FG shielded cable (communication cable) be grounded at its ends. However, the cable may be grounded only at one end if this is necessary due to unstable communication conditions or for any other reason.
- Plug connectors or sockets of MONITOUCH in the correct orientation. Failure to do so may lead to malfunction.
- If a LAN cable is inserted into the MJ1 or MJ2 connector on MONITOUCH, the counterpart device may be damaged. Check the indication on the unit and insert a cable into the correct position.
- Do not use thinners for cleaning because they may discolor the MONITOUCH surface. Use alcohol-based cleaner commercially available.
- If a data receive error occurs when MONITOUCH and the counterpart (PLC, temperature controller, etc.) are started at the same time, read the manual for the counterpart unit and handle the error correctly.
- Avoid discharging static electricity on the mounting panel of MONITOUCH. Static charges can damage the unit and cause malfunctions. Otherwise, malfunction may occur due to noise.
- Avoid prolonged display of any fixed pattern. Due to the characteristics of the liquid crystal display, an afterimage may occur. If a prolonged display of a fixed pattern is expected, use the auto OFF function of the backlight.

[Notes on LCD]

Note that the following conditions may occur under normal circumstances.

- The response time, brightness and colors of MONITOUCH may be affected by the ambient temperature.
- Tiny spots (dark or luminescent) may appear on the display due to the liquid crystal characteristics.
- There are variations in brightness and colors on each unit.
- Cold cathode tubes are incorporated into the LCD display for backlights. Optical properties (brightness, irregular colors, etc.) may change in a low-temperature environment or over time of operation.

Contents

Preface	1-1
About Manuals.....	1-2
V8 Series Models.....	1-3
1. Introduction	
1.1 Installation	
Before Installing V-SFT.....	1-1
Operating Environment.....	1-1
Copyright	1-1
Notes on Usage	1-1
Installation.....	1-2
Installation Procedure	1-2
1.2 Uninstallation	
Uninstalling V-SFT using Start Menu.....	1-6
Uninstalling V-SFT using Control Panel	1-8
1.3 Starting	
Opening a New File	1-10
Opening an Existing File.....	1-13
Saving the File	1-16
Save.....	1-16
Save As	1-17
Closing the File.....	1-18
1.4 Ending	
2. Guide to V8	
2.1 Features	
8-way Communication	2-1
Overview	2-1
Connection Configuration	2-2
Components	2-3
Two Built-in USB Ports	2-3
PictBridge Printer.....	2-3
CF Copy Function.....	2-4
Enhanced Sampling Function.....	2-4
Enhanced Switch Function	2-5
2.2 Screen Composition	
Screen Outline	2-6
What Is an ID?	2-8
ID Number Check	2-10
Screen Structure.....	2-11
Screen Resolution	2-11
Screen Capacity	2-12
Item Types and Placement	2-13
Types	2-13
Capacity for Parts Placement	2-15

3. Device Connection Setting

3.1	Setting Procedure	
3.2	About Device Connection Setting	
3.3	Setting Example	
	For 1:1 Connection	3-3
	Setting Procedure	3-3
	Read/Write Area Settings	3-5
	For 2-way Connection	3-6
	Setting Procedure	3-6
	Read/Write Area Settings	3-11
	About Device Memory Map	3-12
	Overview	3-12
	Setting Procedure	3-13

4. Screen Editing

4.1	Editing Procedure	
4.2	Setting Up Editing Environment	
	Background Color Setting	4-2
	Grid Setting	4-4
	What Is Grid?	4-4
	Grid Setting	4-4
	Display Environment Setting	4-8
	[Display] Tab Window	4-8
	[Others] Tab Window	4-10
4.3	Setting Menus	
	Menu Types	4-12
	Pull-down Type	4-12
	Option Button	4-12
	Numerical Data Entry Box Type	4-13
	Check Box	4-13
	List Type	4-14
	Command Button	4-14
	Underlined Type for Numerical Data Entry	4-15
	Underlined Type for Selection	4-15
	Memory Setting	4-16
	Entry Types	4-16
	Memory Types	4-19
4.4	Drawing	
	Drawing Toolbar	4-22
	How to Display	4-22
	Icons	4-22
	Drawing Method	4-23
	How to Draw a Line	4-23
	How to Draw a Box	4-24
	How to Enter or Place Text	4-25
	Changing the Graphic Properties	4-26
	How to Display the Item Dialog	4-26
	Example of Item Dialog	4-27
4.5	Parts	
	Placement Procedure	4-28
	From the Parts List	4-28
	From the [Parts] Menu	4-30
	From the Parts Toolbar	4-31
	From Catalog View	4-32

How to Modify the Placed Part (For Single Part)	4-34
Item Dialog	4-34
Changing Part Design	4-34
Changing Coordinate and Size	4-37
How to Modify the Placed Part (For Linked Part)	4-39
What Is Linked Part?	4-39
Example of Modification (For Alarm Tracking)	4-41
4.6 Library	
What Is the Library?	4-43
How to Edit the Library	4-44
Message	4-44
Overlap Library	4-45
4.7 Examples of Screen Editing	
Trend Sampling	4-47
Example Screen	4-47
Setting Procedure	4-47
Sampling Operation	4-54
Overlap Display	4-56
Example Screen	4-56
Setting Procedure	4-56
Multi-overlap (Call-overlap) Display	4-66
5. Transfer	
5.1 Transfer Methods	
Data Transfer Method List	5-1
Using a Communication Cable	5-1
V-CP (Serial Port)	5-1
Ethernet (LAN Port)	5-2
USB (USB-B Port)	5-2
Using a Card	5-3
CF Card	5-3
Memory Card	5-3
Using a Modem	5-4
5.2 Transfer Data	
Transfer Data List	5-5
System Program File	5-6
5.3 Preliminaries	
Preparation for MONITOUCH	5-7
New MONITOUCH	5-7
Existing MONITOUCH	5-8
Preparation for Peripheral Equipment	5-9
5.4 Transfer Procedure (Using a Communication Cable)	
V-CP	5-10
System Configuration	5-10
Transfer Procedure from the Editor to MONITOUCH	5-10
Ethernet	5-14
System Configuration	5-14
Transfer Procedure from the Editor to MONITOUCH	5-14
USB	5-19
System Configuration	5-19
Before Transfer via USB	5-19
Transfer Procedure from the Editor to MONITOUCH	5-23

5.5	Transfer Procedure (Using a Card)	
	CF Card	5-26
	System Configuration	5-26
	Transfer Procedure from the CF card to MONITOUCH	5-26
5.6	After Transfer (Communication with PLC)	
	Connection with PLC	5-33
	Preparation for MONITOUCH	5-33
	Switching to RUN (= Communicating) Mode	5-33
	Display Contents after Communication	5-34

6. Simulator

6.1	Overview	
6.2	Operation Procedure	
6.3	Preliminaries	
	Connecting a Computer and the V8 Series	6-3
	V-CP	6-3
	Ethernet	6-4
	USB	6-4
	Transferring Screen Data and the Simulator Program	6-5
	Transfer of Screen Data	6-5
	Setting at MONITOUCH	6-6
6.4	Starting and Ending	
	Starting	6-10
	Ending	6-11
6.5	Start and Stop Communication	
	Starting Communication	6-12
	Stopping Communication	6-12
	Communication Setting	6-13
	Serial Communication	6-13
	Ethernet	6-14
	USB	6-14
6.6	Configuration of Simulator	
	Menu Bar	6-16
	Icon Menu	6-19
	Configuration within a Sheet	6-20
	How to Change the Value (Word Address)	6-21
	[Untitled] Sheet	6-23
	Display Memory	6-25
6.7	Test Example	
	Testing Bit Access Device	6-26
	V8 Series → Simulator	6-26
	Simulator → V8 Series	6-27
	Testing Word Access Device	6-28
6.8	Error List	

1 Introduction

1.1 Installation

Before Installing V-SFT

Operating Environment

Make sure that your system meets the system requirements given in the following table before starting V-SFT version 5.

Computer	PC/AT compatible computer for Windows
OS	Windows 98 SE/Me/NT version 4.0/2000/XP/XP 64 Edition/Vista (32-bit)/ Vista (64-bit)/ 7 (32-bit)/ 7 (64-bit) *
CPU	Pentium III 800 MHz or above (Pentium IV 2.0 GHz or above recommended)
Memory	512 MB or above
Hard disk	Free disk space before installation: 1 GB or more
CD-ROM drive	24x or above recommended
Display	Resolution 1024 × 768 (XGA) or above recommended
Display colors	High color (16-bit) or above

* When installing the application in a Windows NT version 4.0, 2000, XP, XP 64 Edition, Vista (32-bit), Vista (64-bit), 7 (32-bit) or 7 (64-bit) system, you will need Administrator privileges.

Copyright

- The software as well as its copyrights or all other rights related to the software is the property of Hakko Electronics Co., Ltd.
- The software may not be used or copied, in whole or in part, without permission of Hakko Electronics Co., Ltd.
- The specifications and components of the software are subject to change without prior notification.
- Hakko Electronics Co., Ltd., bears no responsibility for the results of using the software.
- You must purchase one set of software for each computer in principle.
- Windows is the registered trademark of Microsoft Corporation in the United States.
- All other company names or product names are trademarks or registered trademarks of their respective holders.

Notes on Usage

- The software may not be correctly installed if resident programs such as a virus scanning program are running. Be sure to close all applications before installing the software.
- For the CD-ROM, the side on which the product name is written is the front face and the side on which nothing is written is the backside.
If the CD-ROM is scratched with a sharp object, it may not be read correctly. The computer reads backside of the CD-ROM. Touching backside of the CD-ROM and leaving fingerprints will result in malfunction. Handle both sides of the CD-ROM with care.
- When placing the CD-ROM in the CD-ROM drive, pay attention to the orientation of the disc and place the disc in the drive as instructed in the instruction manual of your computer.
- If the free space for memory becomes insufficient during running the configuration software, Windows may forcefully terminate the software.
To prevent data from being deleted due to forced termination, save the screen data file regularly.

Installation

Installation Procedure

Follow the procedure below to install V-SFT.

1. Boot computer with Windows operating system.
2. Place the "V-SFT Ver. 5" CD-ROM in the CD-ROM drive.
The display shown below automatically appears on the screen.

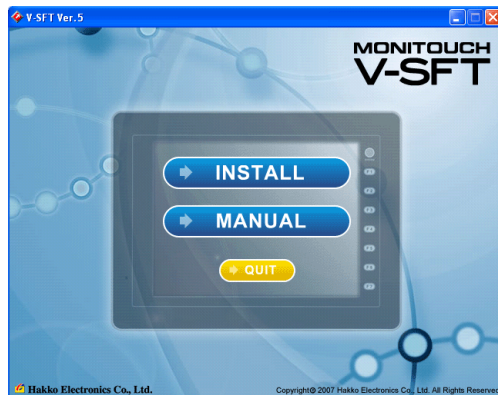

3. Click [INSTALL].

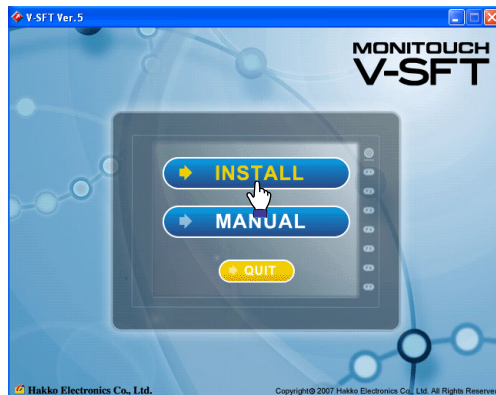

- The following dialog is displayed. Click the [Next] button.

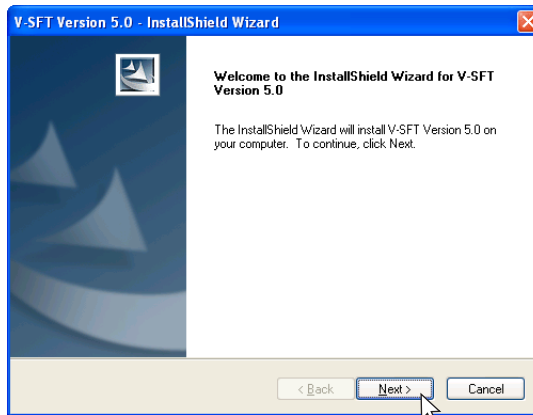

- The [License Agreement] dialog is displayed. Read the contents thoroughly. If you agree to the License Agreement, select [I accept the terms of the license agreement] and click the [Next] button.

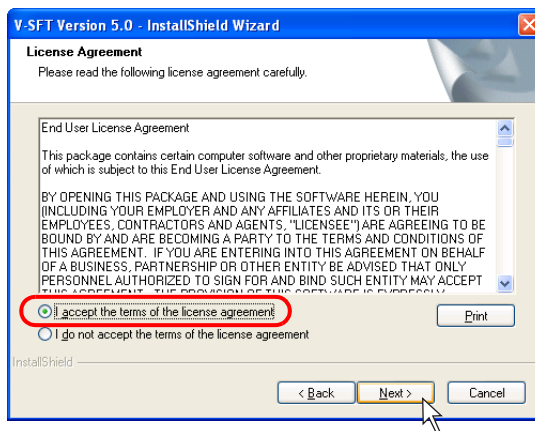

- The [Customer Information] dialog is displayed. Enter a user name and company name, and click the [Next] button.

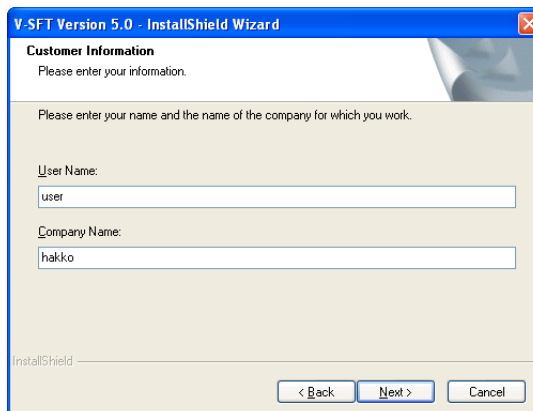

7. The [Choose Destination Location] dialog is displayed. If the designated folder is correct, click the [Next] button. To change the folder, click the [Change] button and select the desired folder. Then click the [Next] button. The default destination location is depending on your OS.
- When OS is Windows XP/2000/98/Me/NT → C:\Program Files\V-SFT V5
 - When OS is Windows Vista/7 → C:\MONITOUCH\V-SFT V5

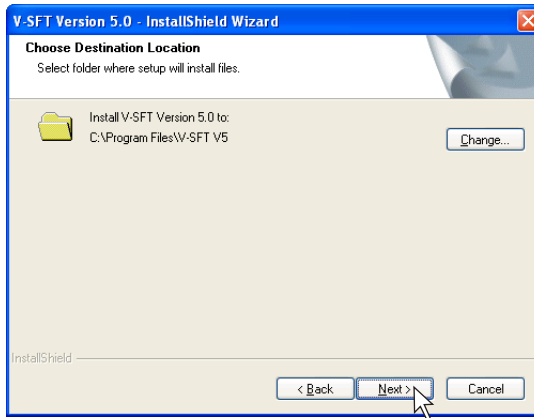

8. The [Ready to Install the Program] dialog is displayed. Click the [Install] button.

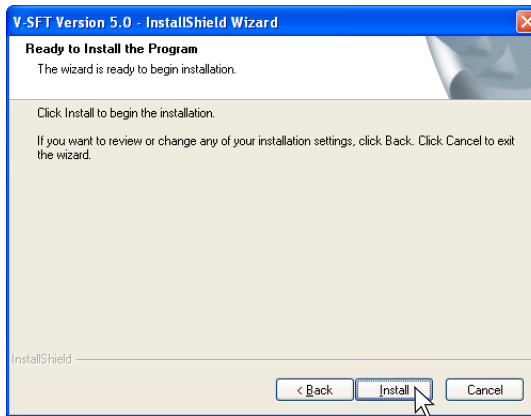

9. Installation starts automatically. To cancel installation, click the [Cancel] button.

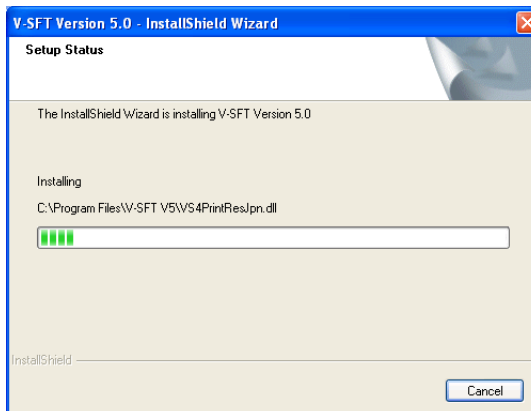

10. When installation is completed, the following dialog is displayed.
If you use dedicated tool to transfer PLC ladder programs via USB or Ethernet, click the [Yes] button. For more information on this tool, refer to the V8 series Reference Additional functions Manual.
When you do not use this tool, click the [No] button.

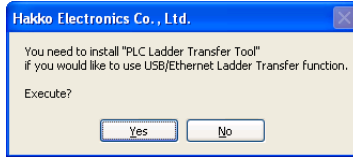

11. When the [No] button is clicked, the following dialog is displayed.

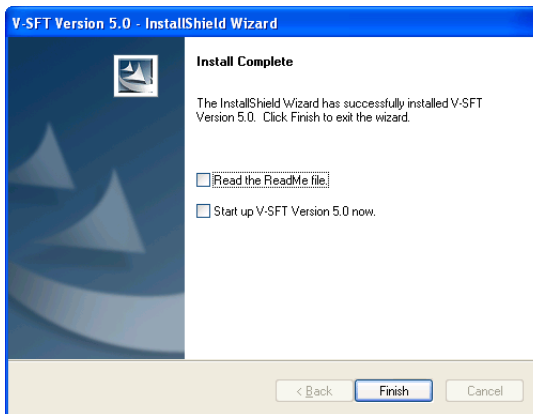

To read the "ReadMe" file, check Read the ReadMe file.
To start-up the editor immediately, check Start up V-SFT Version 5.0 now.
Installation wizard is closed by pressing the [Finish] button.

The installation has been completed.

1.2 Uninstallation

This section describes the procedure for uninstalling V-SFT version 5 installed on the hard disk.

Uninstalling V-SFT using Start Menu

1. Click [Start] → [Programs] → [V-SFTV5] → [Uninstall].

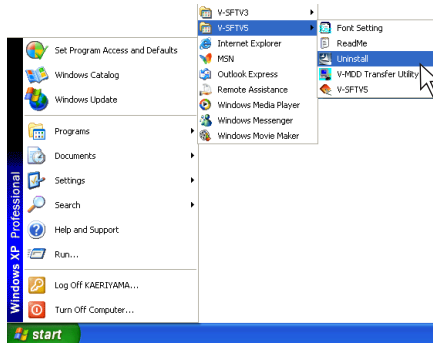

2. The following dialog is displayed.
Select [Remove] and click the [Next] button.

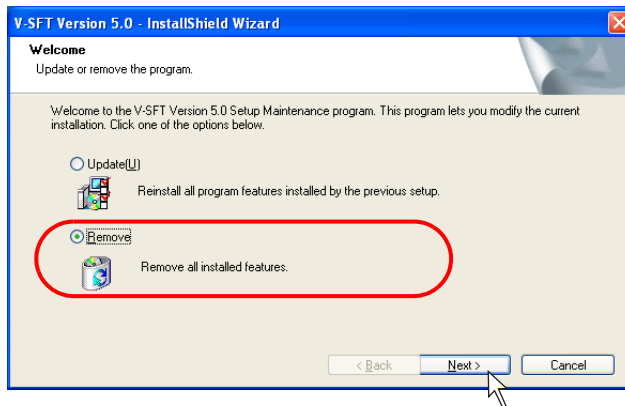

3. The following confirmation message is displayed.
Click [Yes].



4. Uninstallation begins.

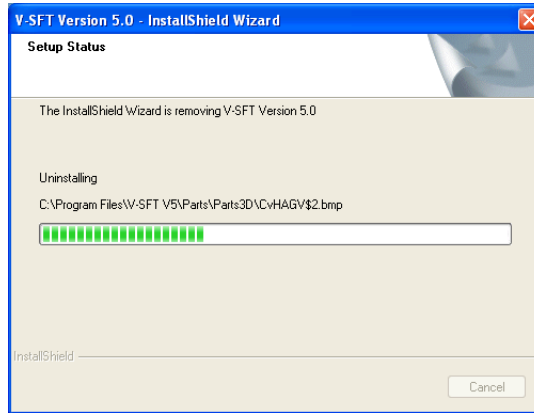

5. When uninstallation is completed, the following dialog is displayed. Click the [Finish] button.



The uninstallation has been completed.

Uninstalling V-SFT using Control Panel

1. Click [Add or Remove Programs] on [Control Panel].

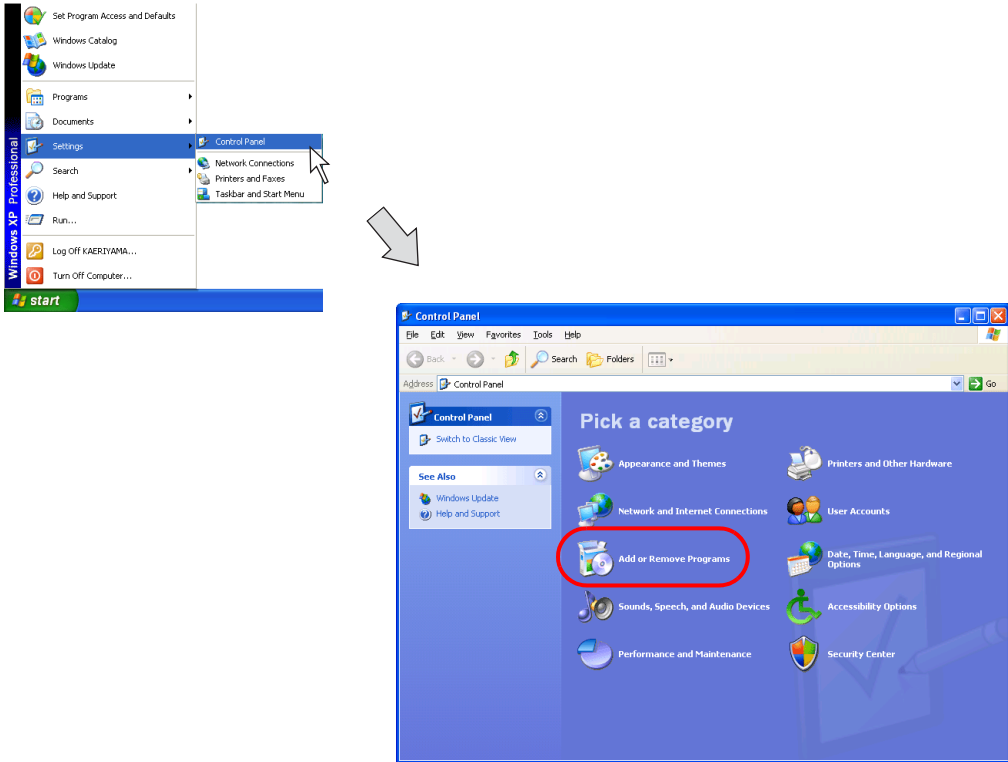

2. The [Add or Remove Programs] dialog is displayed. Select [V-SFT Version 5.0] and click the [Remove] button.

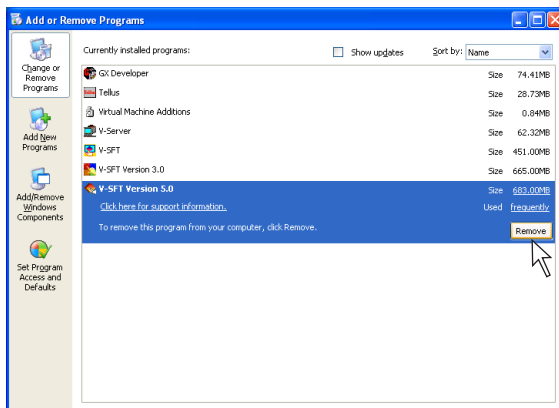

- The following confirmation message is displayed.
Click [Yes].

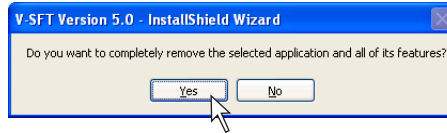

- Uninstallation begins.

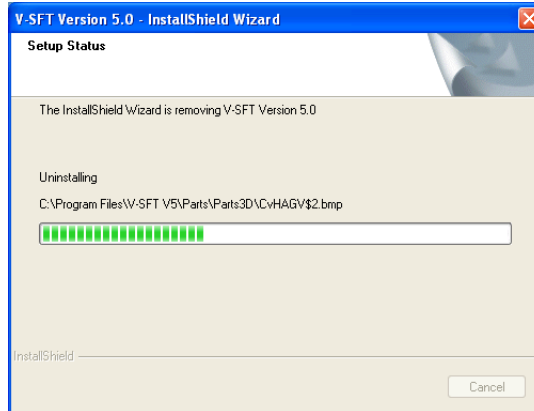

- When uninstallation is completed, the following dialog is displayed.
Click the [Finish] button.



- The [Add or Remove Programs] dialog is displayed again.
To finish uninstalling the software, click the [OK] button.

The uninstallation has been completed.

1.3 Starting

Opening a New File

Start-up the editor and open a new screen file following the procedure below.

1. Click [Start] → [Programs] → [V-SFTV5] → [V-SFTV5].

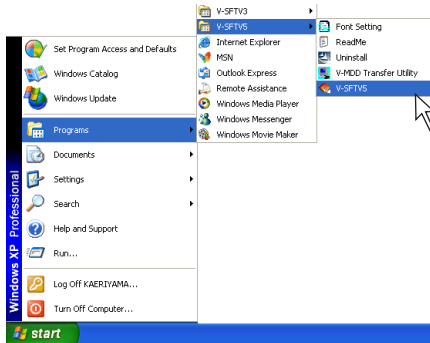

2. V-SFT version 5 is started.

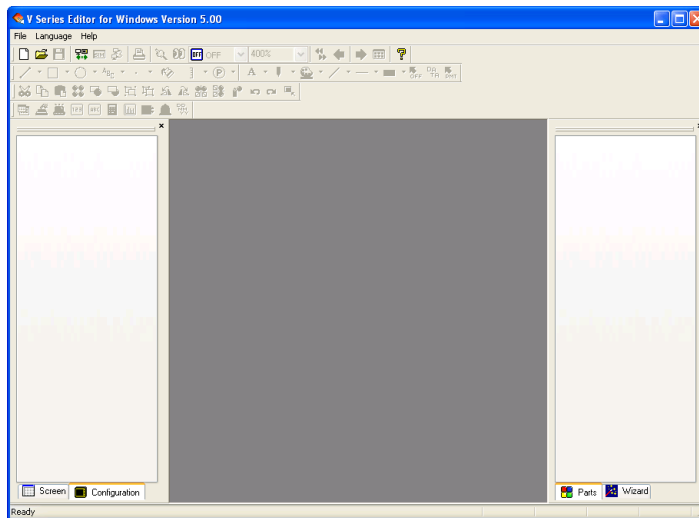

3. Select [New] from the [File] menu or click the [New] icon on the toolbar.

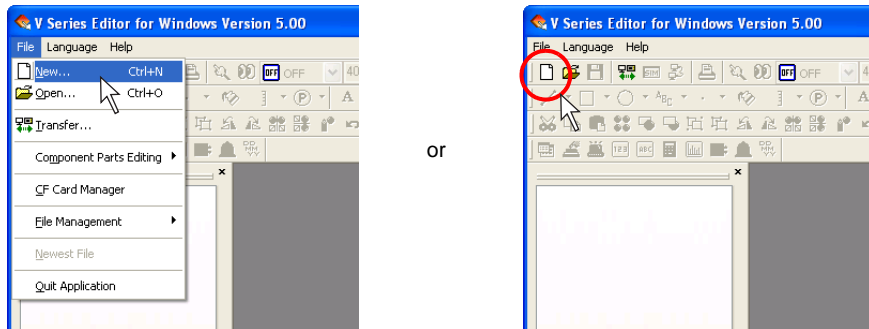

4. The [Edit Model Selection] dialog is displayed. Select the model name and click [OK].

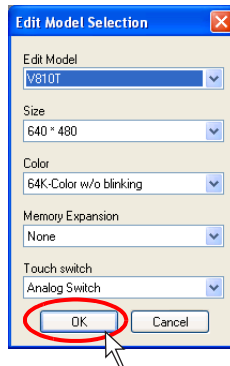

5. The [PLC1 Connection Device Selection] dialog is displayed. Select the PLC type and click [OK].

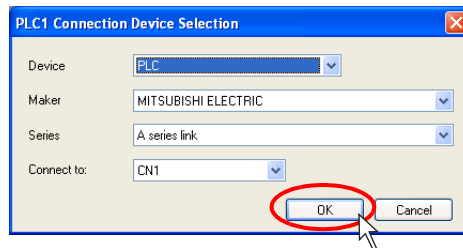

- The [Device Connection Setting] dialog for the device selected and the [Screen [0] Edit ()] window will be displayed at the same time.

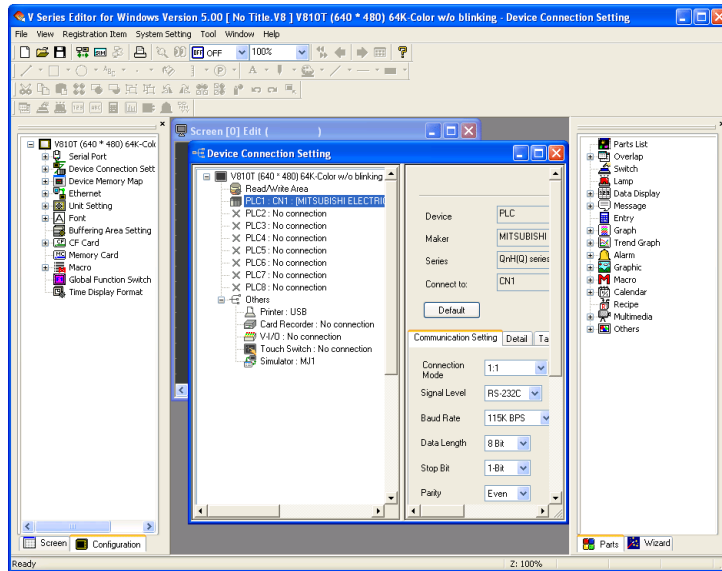

- Make the required settings in the [Device Connection Setting] dialog and close the dialog. The [Screen [0] Edit ()] window will remain displayed: edit the screen in this window. For more information on the [Device Connection Setting] dialog, see “3 Device Connection Setting”.

A new file has been opened.

Opening an Existing File

Open an existing file following the procedure below.

1. Click [Start] → [Programs] → [V-SFTV5] → [V-SFTV5].

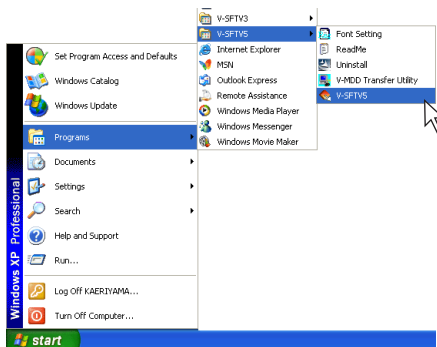

2. V-SFT version 5 is started.

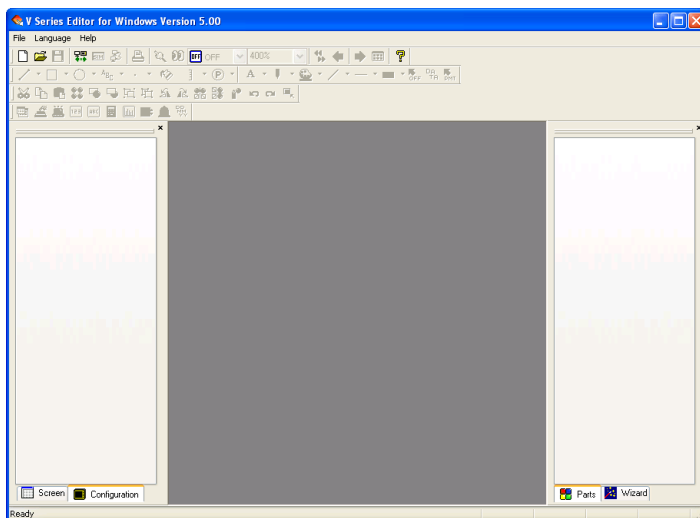

3. Select [Open] from the [File] menu or click the [Open] icon on the toolbar.

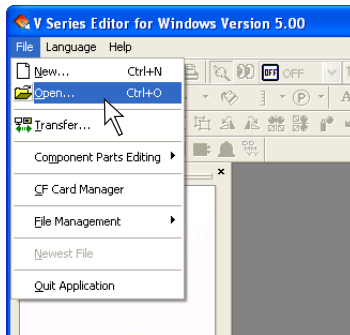

OR

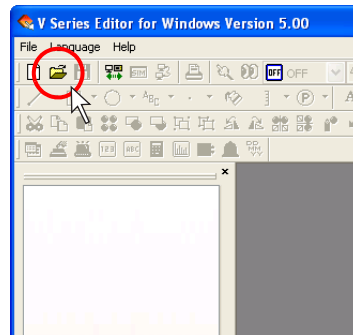

4. The [Open] dialog is displayed.
Select a file type from [Files of type], and select the desired file. Click [Open].

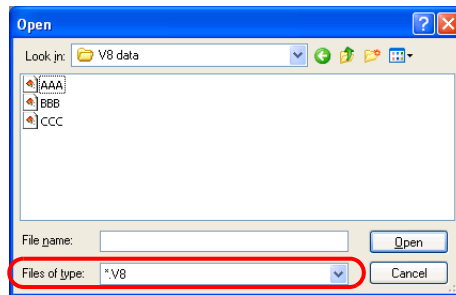

☺ File type

Extension	Target Model	Remarks
*.V8	V8 series	
*.V7	V7 series	
*.V6	V6 series	
*.V4	V4 series	
.80	GD-80/81 series	A file with the extension of ".80" cannot be edited on the V-SFT editor. When a file with the extension of "*.80" file is opened on the editor, it is automatically converted to the V-series data.

5. The selected screen data file is opened.

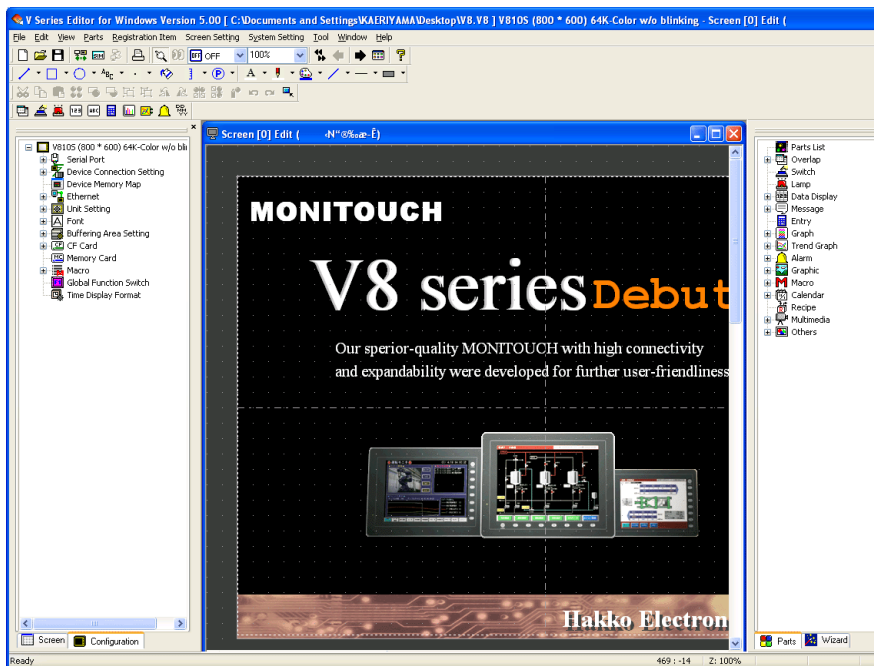

Saving the File

Save

1. Select [Save] from the [File] menu or click the [Save] icon on the toolbar.

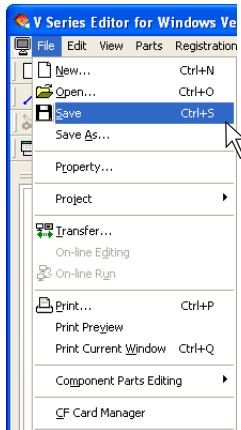

OR



2. When an existing file is opened, it is overwritten at this time. In the case of a new file, the confirmation dialog shown below is displayed. Click [Yes].



3. The [Select the image data to be saved.] dialog is displayed. Give a name to the file and click [Save].

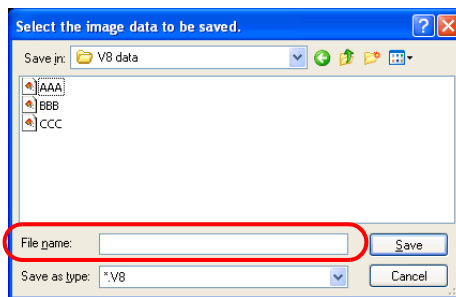

The screen data file has been saved.

Save As

1. Select [Save As] from the [File] menu.

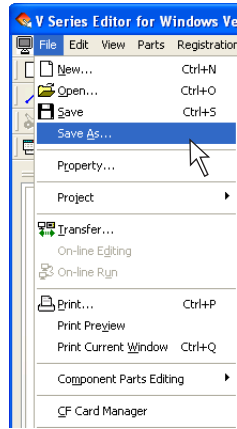

2. The [Select the image data to be saved.] dialog is displayed. Give a name to the file and click [Save].

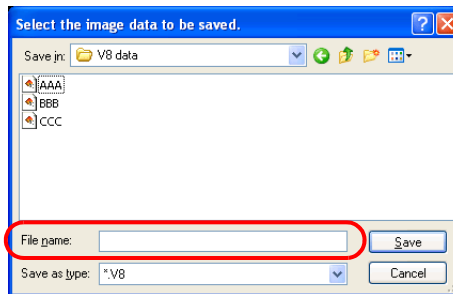

The screen data file has been saved.

Closing the File

1. Click the icon on the top left corner of the [Screen Edit] window and select [Close].
Alternatively, click the [X] button on the top right corner of the [Screen Edit] window.

Click the icon of the [Screen Edit] window.

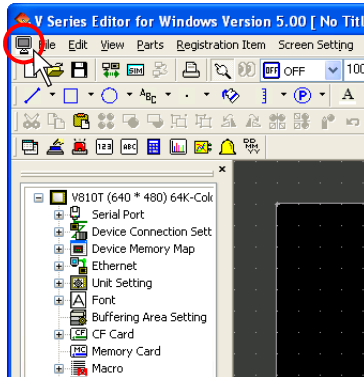

Click [Close].

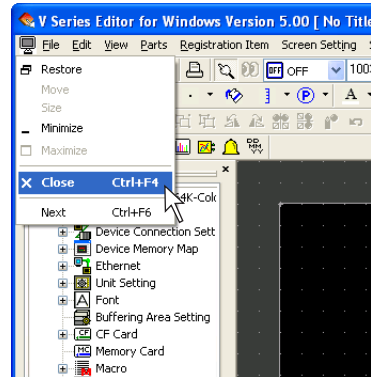

OR

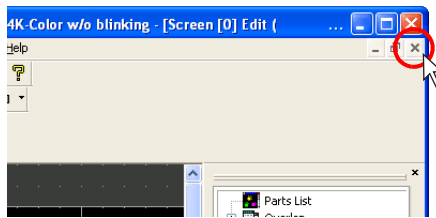

2. The file is closed.



If you have created a new file and attempt to close it, the confirmation dialog shown below is displayed.
Save the file if necessary.



1.4 Ending

Exit V-SFT version 5 following the procedure shown below.

1. Select [Quit Application] from the [File] menu or click the [x] button in the upper right corner of the screen.

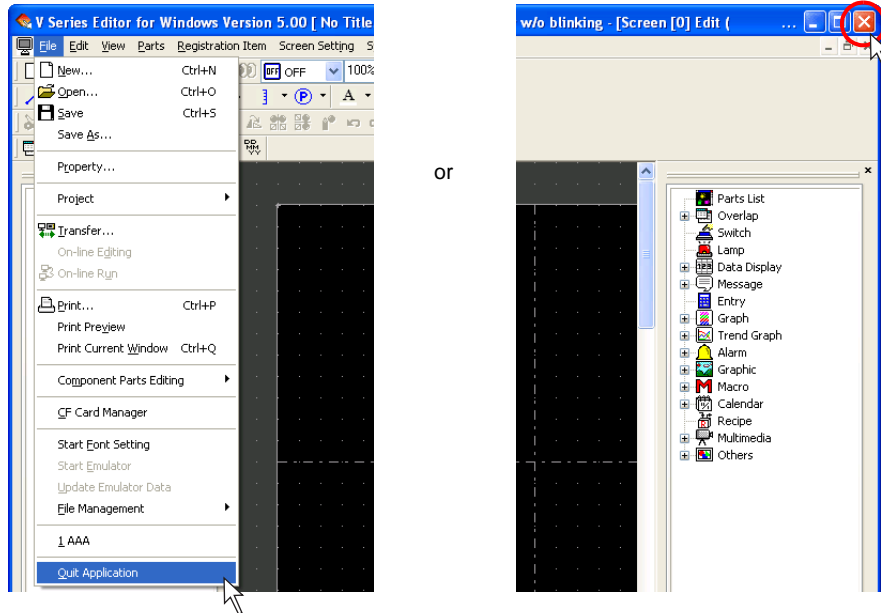

2. The file is closed.



If you have created a new file and attempt to close it, the confirmation dialog shown below is displayed.
Save the file if necessary.



MEMO



Please use this page freely.

2 Guide to V8

2.1 Features

8-way Communication

Overview

- The V8 series is equipped with five physical ports consisting of three serial ports, one LAN port, and network communication port^{*1}. The LAN port can open eight ports at the same time. You can use the physical ports to connect a maximum of eight different models of devices and allow the V8 series to communicate with them at the same time. This is called the 8-way communication.

*1 A communication interface unit (CU-xx) is required to enable network communication.

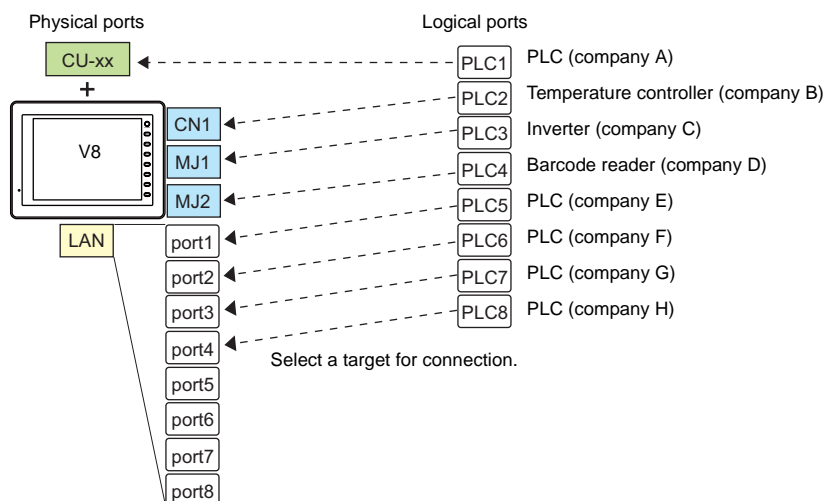

- This makes it possible to connect to multiple devices of different models, and to PLCs made by other manufacturers.

Example 1: Serial communications

The V8 series is allowed to communicate with three different models of devices at the same time via three serial ports. A maximum of 31 units of the same model can be connected to each port.

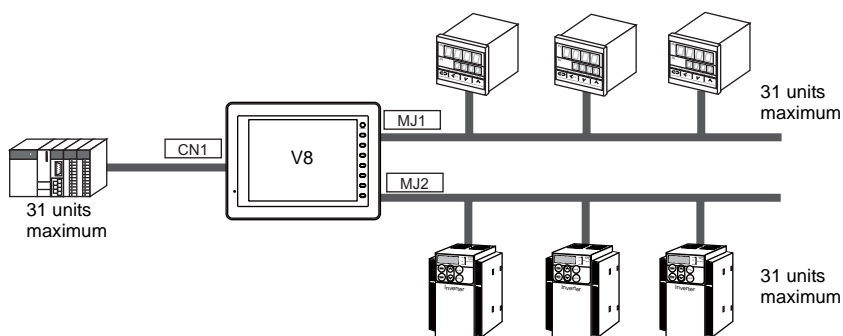

Example 2: Mixed serial-Ethernet communications

In the case of mixed serial-Ethernet communication, the V8 series is allowed to communicate with eight different models of devices at the same time.

(Connection of three models for serial communication and five models for Ethernet communication)

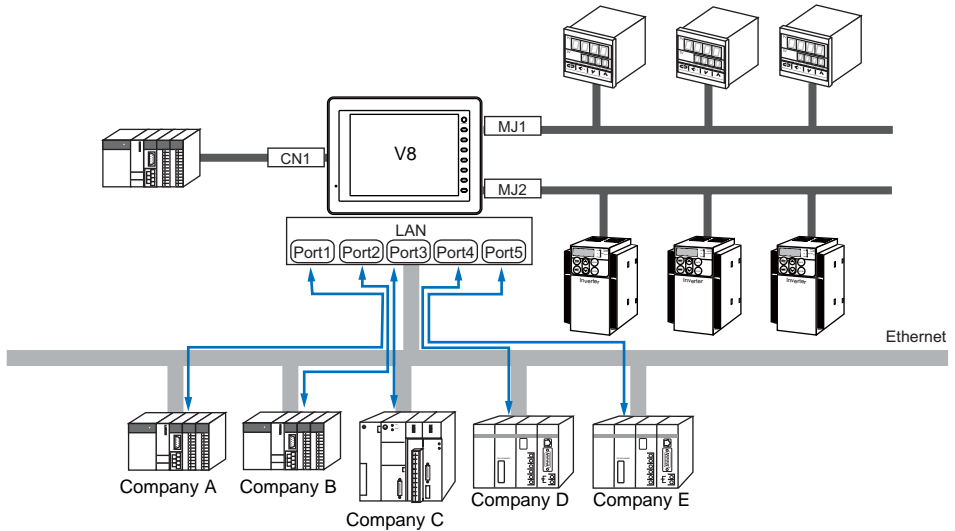

Connection Configuration

The types and number of ports that can be connected in 8-way communication are indicated in the table below.

Physical Ports		Number of Ports	Applicable Devices
Serial	CN1	1	PLC/ temperature controller/ servo/ inverter/ barcode reader
	MJ1	1	PLC/ temperature controller/ servo/ inverter/ barcode reader/ V-Link/ slave communication (Modbus RTU)
	MJ2	1	
Ethernet	LAN	8	PLC/ slave communication (Modbus TCP/IP)
Network	OPCN-1	CU-00	PLC
	T-Link	CU-01	
	CC-Link	CU-02	
	Ethernet	CU-03-3	
	PROFIBUS-DP	CU-04	
	DeviceNet	CU-07*	
	FL-Net	CU-08	

* Under development

- Only the logical port PLC1 can be selected for the following devices and functions. Thus, they cannot be connected at the same time.
 - Devices
Network connection (CU-xx), without PLC connection, Allen-Bradley Control Logix, Siemens S7-200PPI, Siemens S7-300/400MPI connection
 - Functions
Multi-link2, Multi-link, ladder transfer, ladder monitor, Micrex SX variable name cooperation function

Components

Creations completed by combining different parts and items to achieve an assembly that performs a particular function are supplied as “components”.

This means that the required functions can be realized simply by putting the right components in place, without the need to make complex settings.

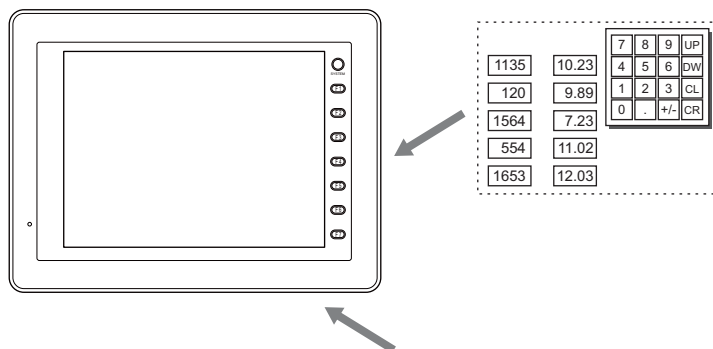

With “component parts”, which are assemblages of items created to perform particular functions, the functions can be performed easily just by putting the component parts into place.

Two Built-in USB Ports

The V8 series has two built-in USB ports as standard.

This allows the use of the following functions.

PictBridge Printer

Connecting a USB-B port allows use with a PictBridge printer.

It is possible to connect directly to PictBridge printers, which are widely used with digital cameras, to make hard copies or print documents.

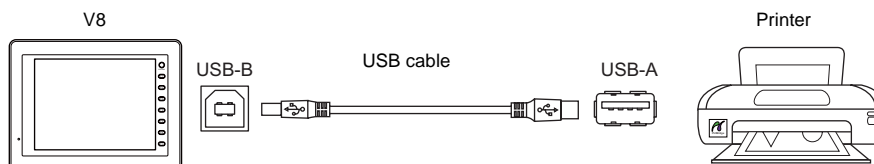

CF Copy Function

Apart from the built-in CF card it is also possible to connect a USB-CFREC to the USB-A port, which means that CF cards can be connected to two drives.

This makes it possible to copy data stored in the built-in CF card to a USB-CFREC.

This facility can be used to make backup copies of data, and to transfer data to the PC.

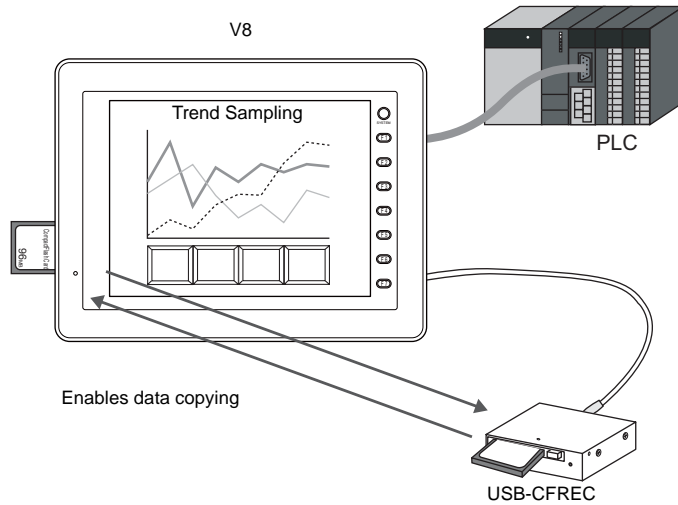

For copying, use the [COPY_FILE] macro command.

For more information, refer to the Macro Reference manual.

Enhanced Sampling Function

- The “sampling function” that accumulates changes in data and alarm statuses, etc. has been enhanced. Because the storage target for data has been split into primary and secondary targets, you can now back up data located e.g. in the CF card by sending it to storage media without stopping sampling operation. This has enabled continuous monitoring without creating gaps in sampling whenever data is backed up.

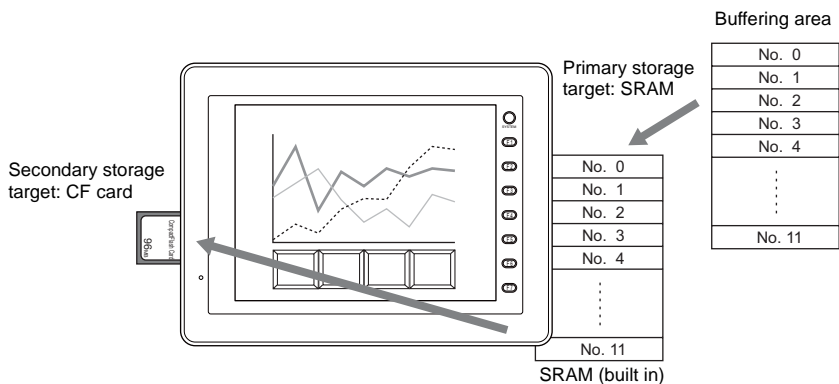

- Sampling processing is now high speed. Data is stored without any dependence on the screen status.

Enhanced Switch Function

- On pressing a switch, ON/OFF information or a value can be sent to multiple bits or words (e.g. in the PLC memory or internal memory) at the same time. (Multi-output function)

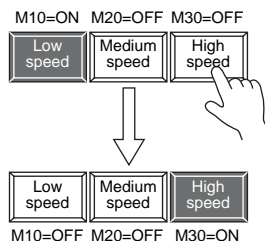

Pressing the [High speed] switch can serve not just to turn M30 ON, but to turn M10 and M20 OFF at the same time.

This makes it simple to create radio buttons.

- Switches now feature a delay function. You can set "ON delay" functions, where memory output cannot occur unless the switch is pressed continuously for a fixed time, and "OFF delay" functions, where the memory cannot go OFF until a fixed time has elapsed after you have released your finger from the switch.

For example, on pressing a switch for which [Output Memory: M10] and [ON delay: 3 sec] have been set, M10 will be turned ON after the switch has been pressed continuously for 3 seconds.

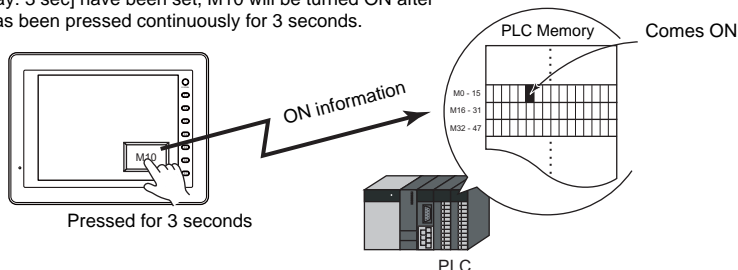

- You can set a confirmation dialog to be displayed automatically when a switch is pressed and ask whether the operation is [OK] or should be canceled ([Cancel]). You can make the settings for confirmation and operation execution entirely on MONITOUCH, without the need for troublesome programming.

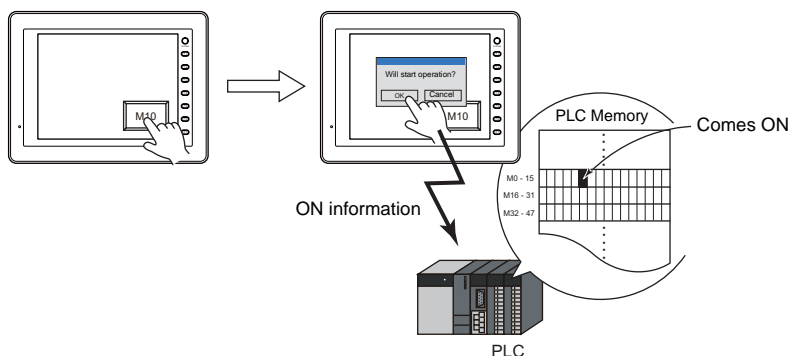

2.2 Screen Composition

Each display of MONITOUCH is collectively called “screen”.

A maximum of 1,024 screens can be registered in one screen data file.

This section explains the screen composition and elements (parts and graphics) to be displayed on the screen.

Screen Outline

- One screen is composed of a base screen (indispensable) and overlap displays (maximum of three overlap displays can be placed).

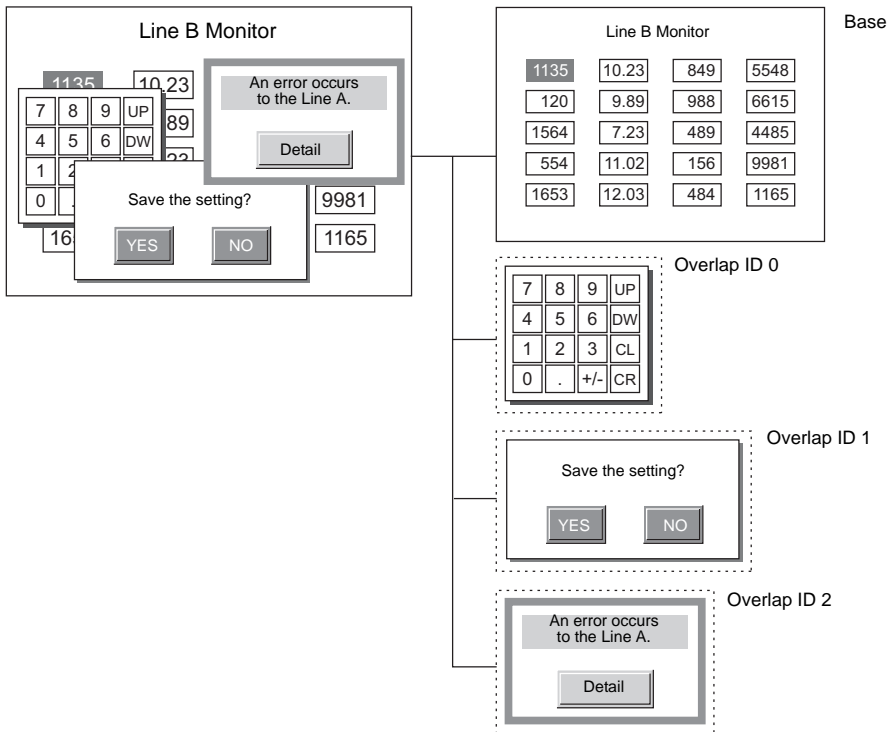

- Each base screen is composed of 256 areas called “ID”. These 256 IDs are overlaid like invisible sheets.

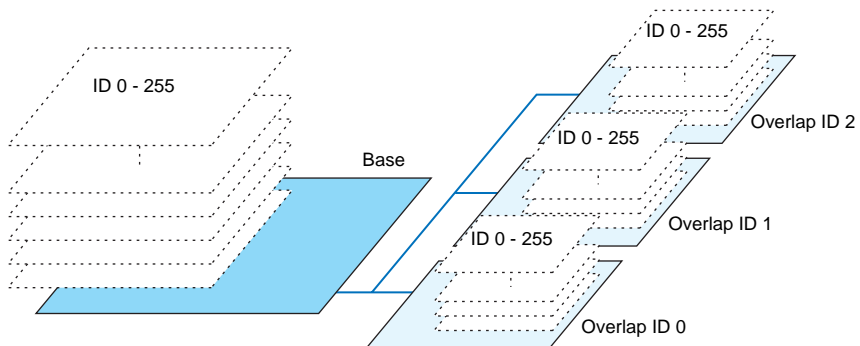

- Each sheet contains "parts". These parts are given numbers identical to their respective sheet numbers (= ID numbers). Graphics are placed directly on the base screen or overlap displays. These graphics are not given ID numbers.

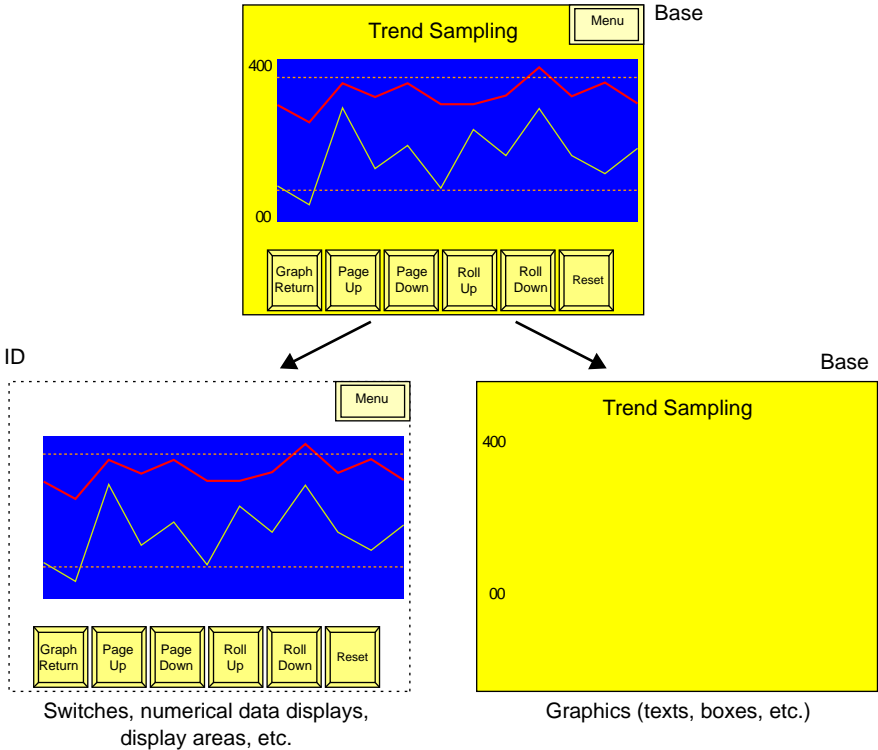

What Is an ID?

- “ID” is a number given to each invisible sheet.
Each part that configures the screen function is placed on the sheet. To identify the sheet respectively, an ID number is assigned to each part.
Depending on the part type, one sheet can contain multiple parts or only one part.
(For more information on the restrictions on part placement, see page 2-15.)
- The editor automatically allocates ID numbers to parts. Normally, you do not need to worry about the allocation of ID numbers.

For parts, such as a switch, lamp, numerical data display, or bar graph, which can execute their own function individually, any number of parts can be placed on the sheet (see page 2-15). It is not necessary to worry about ID numbers when placing these types of parts.
For a part that can be placed only one per sheet, see the description below.

Combination of parts

To achieve an assembly that performs a particular function by combining different parts, all parts must have a common ID number.

- Error message display (= alarm display)
- Numerical data entry on MONITOUCH (= entry mode)

Specify the same ID number for the display area as the one for the scroll switches.

Alarm Display

ind roller error	16:15:43	16:21:12
sensor error	16:15:51	16:21:54
roller error	16:15:52	16:21:55
Second sensor error	17:05:02	18:08:01
Third sensor error	17:06:31	18:08:01
Fifth roller error	19:21:30	21:09:44
Fourth sensor error	19:22:45	21:10:22

UP DW + - RET DEL RESET

Entry Mode

Max. value 1234
Min. value 1234
Entered Value 1234

Numerical data 1: 1234
Numerical data 2: 1234
Numerical data 3: 12.34
Numerical data 4: 12.34
Text 1: ABCD

8 9 UP
4 5 6 DW
1 2 3 CL
0 . +/- CR

Specify the same ID number for all parts.

If a part having a different ID number is contained, the function will not work correctly.
Check the ID number and specify the number correctly.

When using a screen library:

With the use of the editing area called "screen library", the same part can be placed repeatedly on multiple screens.

Before using this function, check that the ID number registered in the screen library is different from any ID numbers already placed on the screen.

If the ID number registered in the screen library overlaps with the one that has a restriction on the number that can be placed on one screen, the function will not work correctly.

(For more information on the screen library, refer to the V8 Series Operation Manual.)

When the ID number for the alarm display part is set to "10":

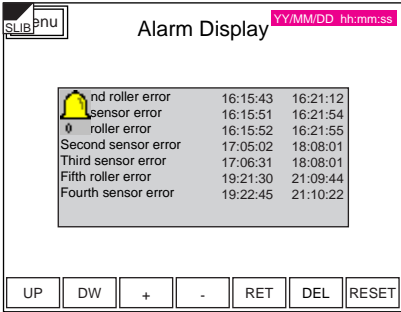

When the ID numbers for the entry mode part is set to "0":

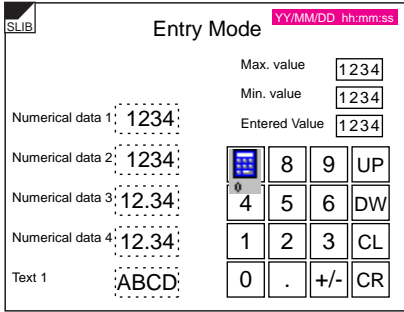

For the calendar part that is placed on both screens, the ID number must be set to the number other than "0" or "10".

ID Number Check

To check the ID number of the part placed on the screen, select [Display Environment] from the [View] menu. Then, check [Display ID Number] for [Detail].

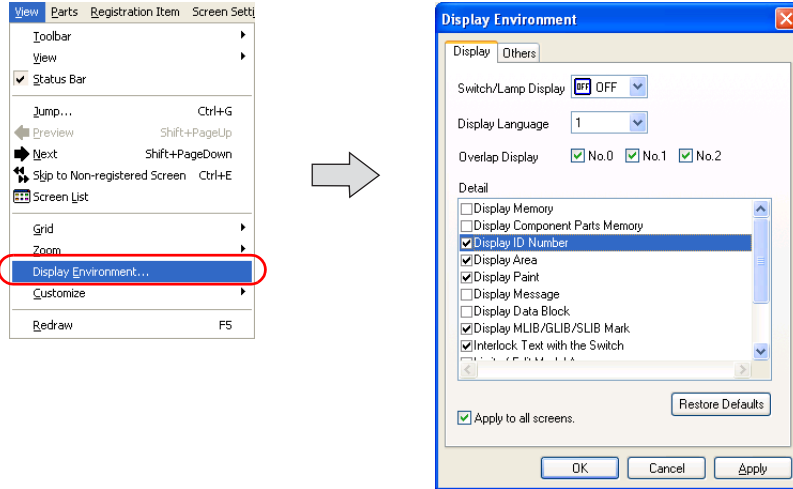

 : Displayed ID number

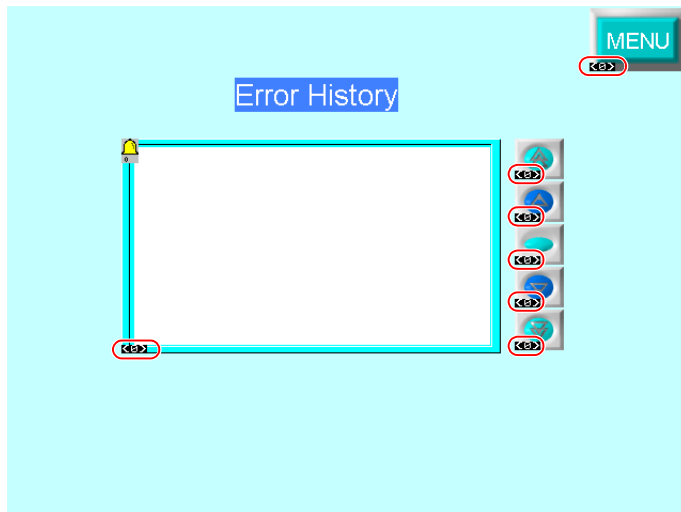

For more information on the [Display Environment] setting, see "Display Environment Setting" in "4.2 Setting Up Editing Environment" (page 4-8).

Screen Structure

Screen Resolution

Depending on the MONITOUCH model, the screen resolution varies.

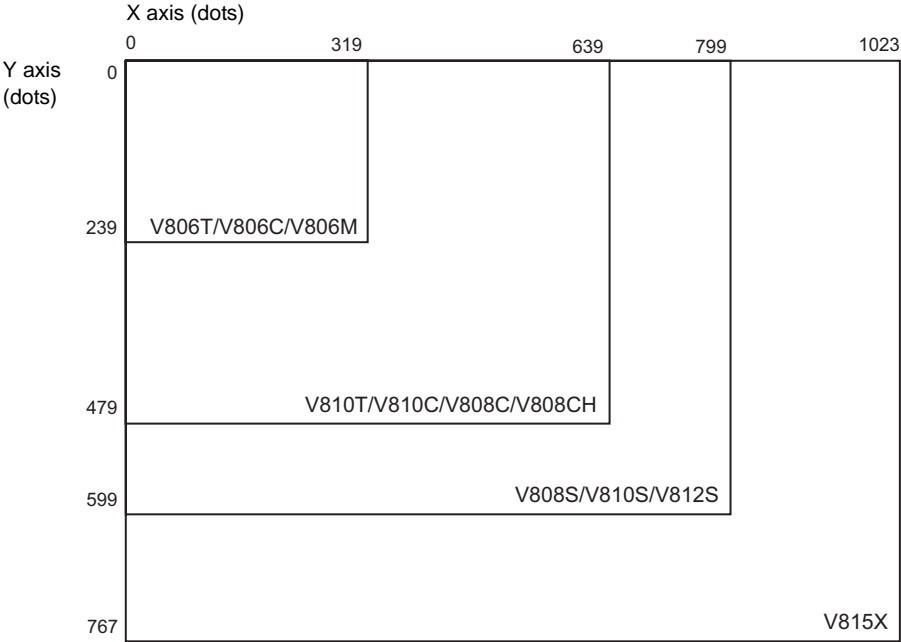

Lines and columns

Lines and columns are used as units to designate coordinates of overlap displays or sizes of character displays.

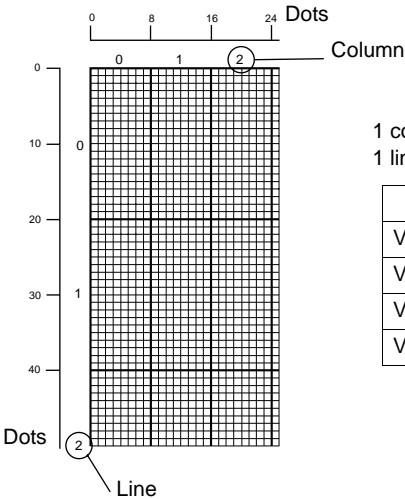

1 column = 8 dots
1 line = 20 dots

Model	Column	Line
V806T/V806C/V806M	40	12
V810T/V810C/V808C/V808CH	80	24
V808S/V810S/V812S	100	30
V815X	128	38

Screen Capacity

- There is no particular capacity per screen with the V8 series (with the V7 series it is 256 kB and with the V6 series it is 128 kB).
However, there are restrictions on the number of items that can be registered.
For more information, see “Capacity for Parts Placement” (page 2-15).
 - One file is capable of storing 4,000 screens.
 - The capacity per file varies depending on the MONITOUCH model as well as the font type in use.
For more information, refer to “Appendix 3 Display Language” in the V8 Series Reference Manual.
 - Be sure to check the environment you use and available memory when registering screens.
- * **If a file that includes a screen data exceeding the capacity per screen is transferred to MONITOUCH, the function set for the data will not work correctly. Be sure to create every screen within the capacity.**
- * **If a screen data file exceeds the maximum capacity, an attempt to transfer the file causes an alarm message “The size is too large to communicate” and results in transmission failure.**

Item Types and Placement

Types

Parts		Type	Remarks
Overlap	Normal Overlap	SP	SP: single part
	Call-overlap	I	I: item which does not have an area
	Multi-overlap	I	
Switch		SP	
Lamp		SP	
Data Display	Numerical Data Display	SP	
	Character Display	SP	
	Message Display	SP	
	Table Data Display	SP	
Message	Message	MP	MP: combined parts
	Comment Display	MP	
Entry		MP	
Slider Switch		SP	
Graph	Bar Graph	SP	
	Pie Graph	SP	
	Closed Area Graph	SP	
	Panel Meter	SP	
	Statistic Bar Graph	SP	
	Statistic Pie Graph	SP	
Trend	Trend Graph	SP	
	Trend Sampling	MP	
	Data Sampling	MP	
Alarm	Alarm Display	MP	
	Bit Order Alarming	MP	
	Alarm Sub Display	MP	
	Time Order Alarming	MP	
	Alarm Logging	MP	
Graphic	Graphic	MP	
	Graphic Relay	MP	
Macro	Macro	I	
	Interval Timer	I	
Calendar	Time Display	I	
	Calendar	SP	
Recipe		MP	
Multimedia	Animation	MP	
	Video	MP	
	JPEG Display	MP	
	Sound	I	
	Network Camera	MP	
	Remote Desktop Window Display	MP	

2.2 Screen Composition

Others	Data Block Area	MP	
	Memory Card	MP	
	Memo Pad	MP	
Screen Library (*1)		I	

*1 The screen library type differs depending on items registered in the screen library.

Capacity for Parts Placement

When placing parts on a screen, there is a restriction on the number that can be placed on one screen, which depends on the type of part. For details on the restrictions on part numbers, refer to the table below.

Parts		Restrictions per ID	Restrictions per Base/Overlap	Restrictions per Screen		
				V815iX V812(i)S V810(i)T/S V808(i)S	V810(i)C V808(i)C V808(i)CH	V806
Overlap	Normal Overlap	-	-	3		
	Call-overlap	-	-			
	Multi-overlap	-	-			
Switch		None	None	1024 (*1)		192 (*1)
Lamp		None	None	1024		192
Data Display	Numerical Data Display	None	None	Setting memory		
	Character Display	None	None	Setting memory		
	Message Display	None	None	Setting memory		
	Table Data Display	1	256	Setting memory		
Message	Message	1	256	Setting memory		
	Comment Display	1	256	Setting memory		
Entry		1	1	4		
Slider Switch		None	None	1024 (*1)		192 (*1)
Graph	Bar Graph	None	None	Setting memory		
	Pie Graph	None	None	Setting memory		
	Closed Area Graph	None	None	Setting memory		
	Panel Meter	None	None	Setting memory		
	Statistic Bar Graph	1	256	Setting memory		
	Statistic Pie Graph	1	256	Setting memory		
Trend	Trend Graph	1	256	Setting memory		
	Trend Sampling	1	256	Setting memory		
	Data Sampling	1	256	Setting memory		
Alarm	Alarm Display	1	256	Setting memory		
	Bit Order Alarming	1	256	Setting memory		
	Alarm Sub Display	1	256	Setting memory		
	Time Order Alarming	1	256	Setting memory		
	Alarm Logging	1	256	Setting memory		
Graphic	Graphic	1	256	Setting memory		
	Graphic Relay	1	256	Setting memory		
Macro	Macro	1	256	Setting memory		
	Interval Timer	1	256	Setting memory		
Calendar	Time Display	None	None	Setting memory		
	Calendar	1	256	Setting memory		
Recipe		1	4	Setting memory		

Parts		Restrictions per ID	Restrictions per Base/Overlap	Restrictions per Screen		
				V815iX V812(i)S V810(i)T/S V808(i)S	V810(i)C V808(i)C V808(i)CH	V806
Multimedia	Animation (*2)	1	256	Setting memory	-	-
	Video (*2)	1	4	4	-	-
	JPEG Display (*2)	1	256	Setting memory		
	Sound	1	256	Setting memory	-	-
	Network Camera (*2)	1	1	4		
	Remote Desktop Window Display (*2)	1	1	4 (Not available with matrix type)		
Others	Data Block Area	1	4	4		
	Memory Card	1	1	4 (*3)		
	Memo Pad	1	1	1 (Not available with matrix type)		
Screen Library		None	None	(*4)		

- *1 Switches, slider switches, and scroll switches are included in these limits.
- *2 These parts are not available with the 128-color type and the V806M model.
- *3 A maximum of four memory card mode parts can be set on one screen though available functions are limited.
For instance, two parts of one screen cannot contain one list display each. But it is possible that one part contains one list display, and a different part of the same screen contains one format screen.
- *4 When a screen library is placed on the screen, the parts registered in the screen library are subject to the same limit items in the chart above.

Setting memory

“Setting memory” in the chart above means the number of memory locations, which is read on one screen. This does not mean the number of words used on a screen.

The maximum number of memory locations varies depending on the model of MONITOUCH.

Model	No. of Memory Locations per Screen
V8 series	1024
V806 series	256

The read area under [System Setting] is counted as one memory location. (The write area is not the count target.) Therefore, to determine the maximum number of memory locations for a part, subtract one from the number indicated in the above table.

<Examples>

- One memory location is counted even when 10 words are used in the relay mode.
- Switch output memory is not counted as setting memory. For lamp memory, however, one is counted for each lamp memory location used.
- Each data display is counted as one memory location. If maximum and minimum values are set, one memory location each is counted. Therefore, it is counted as three in total.

3 Device Connection Setting

3.1 Setting Procedure

The flow of the operations from setting a new V8 series screen to transferring it to MONITOUCH is shown below.

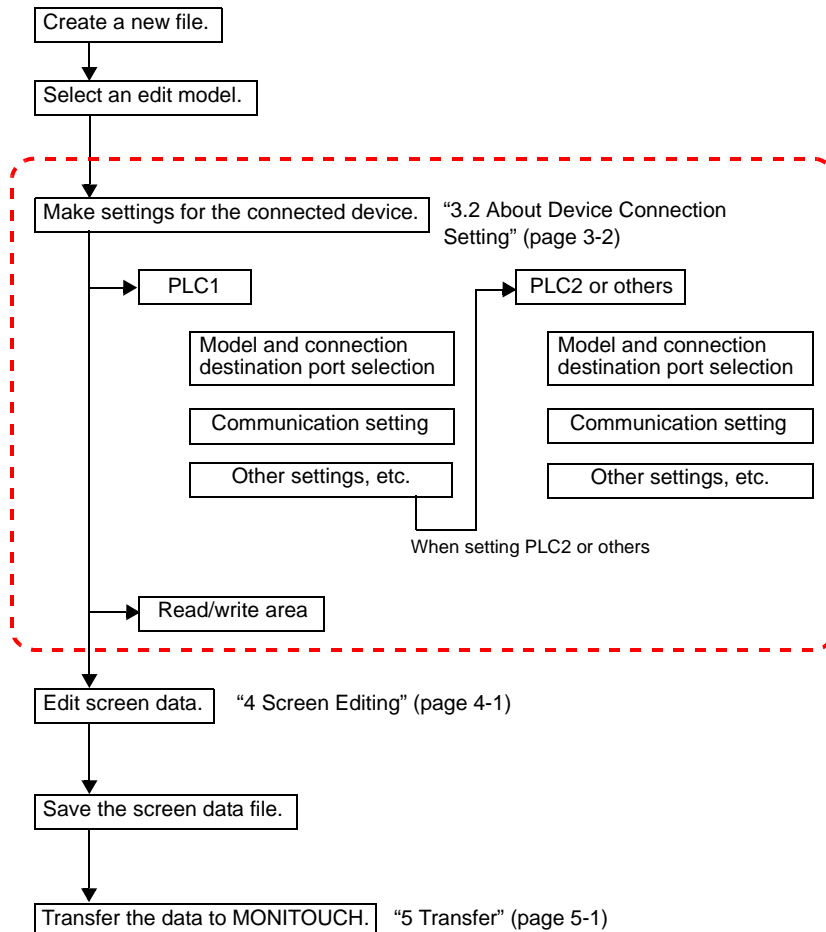

This chapter gives a detailed explanation of the setting procedure inside the dotted line frame in the figure above.

3.2 About Device Connection Setting

- The menu option that is used to make the connection port, communication and other settings for connecting the V8 series unit and other devices is [Device Connection Setting]. When creating a new file, the dialog always starts up automatically.
- When you want to edit an existing file you can display the dialog by clicking [System Setting] → [Device Connection Setting].

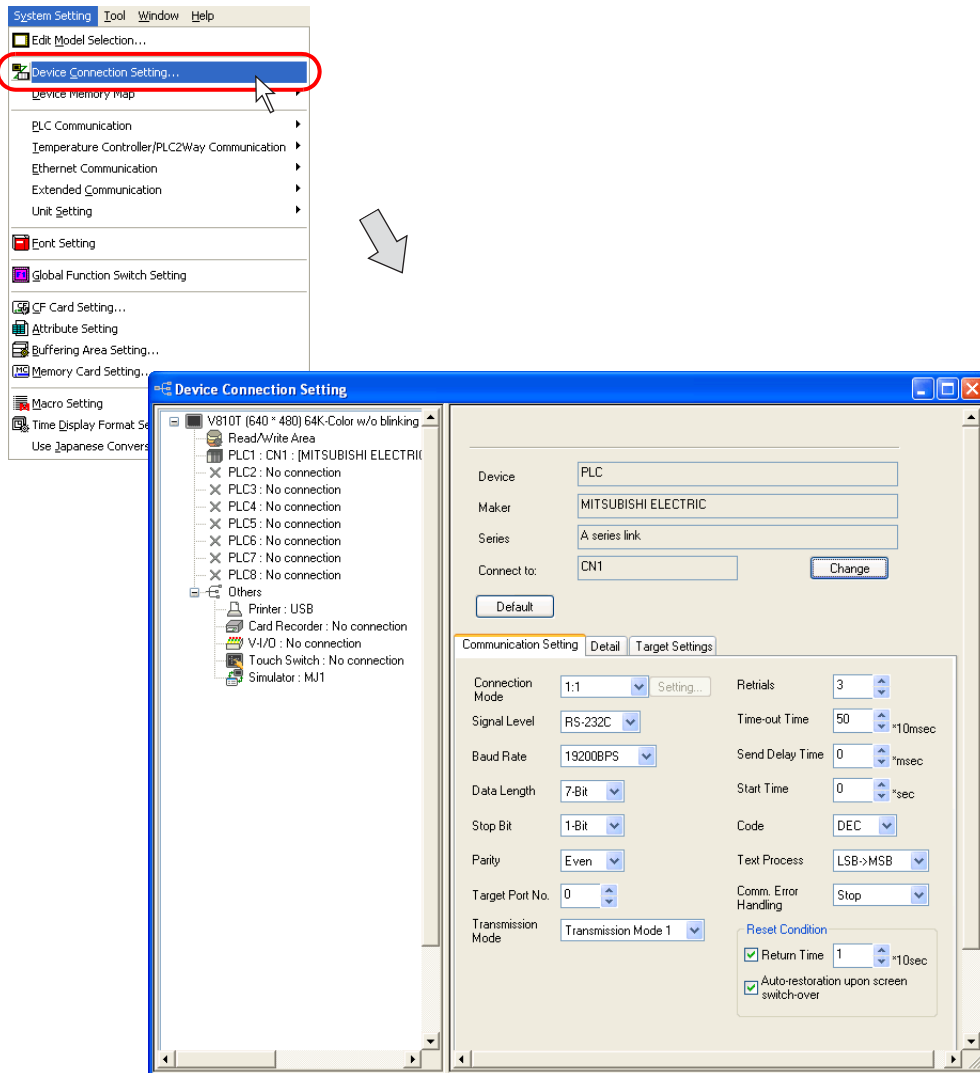

- Apart from devices included in “8-way communication” like PLCs, temperature controllers and inverters, the settings for connection to other devices such as printers and V-I/O devices are also made here.

3.3 Setting Example For 1:1 Connection

This section explains the setting procedure for connection to a V8 series unit with a device configuration like that shown below.

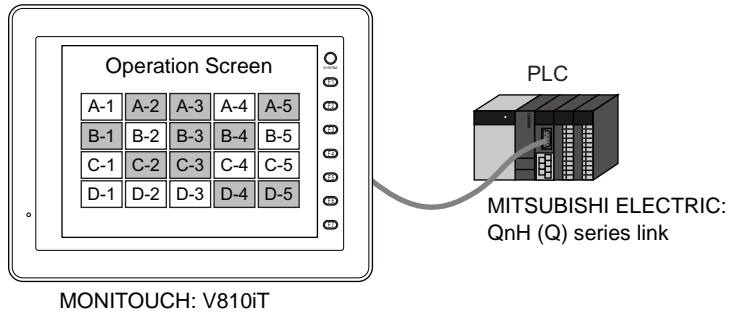

Setting Procedure

1. Select [New] from the [File] menu or click the [New] icon on the toolbar.
The [Edit Model Selection] dialog is displayed.

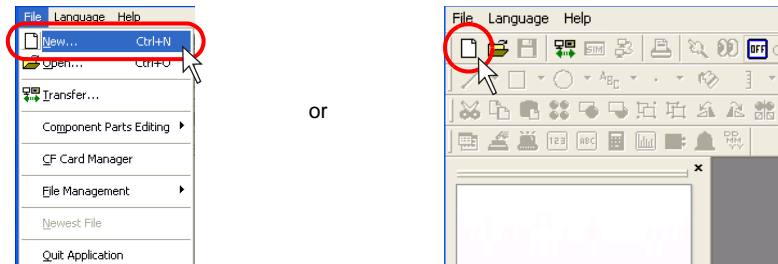

2. Select a model for [Edit Model]. In this example, we select "V810T".
For [Color], select [64K-Color w/o blinking] and for [Touch switch] select [Analog Switch], then click [OK].

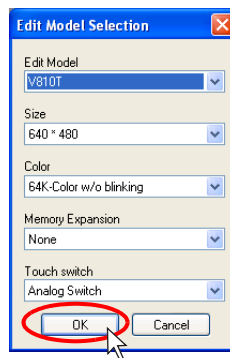

3. The [PLC1 Connection Device Selection] dialog is displayed.
Make settings as shown below.

Device: PLC
 Maker: MITSUBISHI ELECTRIC
 Series: QnH (Q) series link
 Connect to: CN1

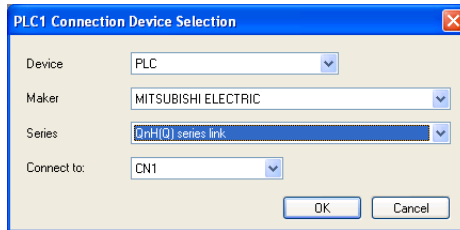

4. On clicking [OK] the [Device Connection Setting] dialog starts up and you can check the settings for PLC1.

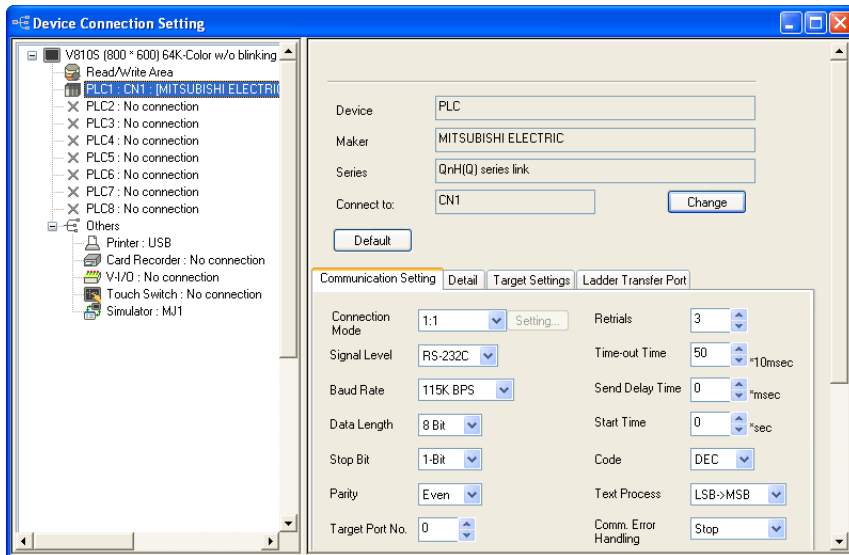

5. Set each of the parameter settings in the [Communication Setting] tab window so that they agree with those of the target PLC (in this example a “QnH (Q) series link” by MITSUBISHI).

☺ If the settings at MONITOUCH don't agree with those at the PLC, [Communication Error PLC1 Time-Out] will be displayed at MONITOUCH and communications will not take place normally. Be sure to check the settings at both sides.

Read/Write Area Settings

- When creating a MONITOUCH screen data file, you must secure areas called the “read area” and “write area”. These areas can either be set as addresses at the PLC, or in the internal memory at MONITOUCH.
- The “read area” and “write area” settings are made on the [Device Connection Setting] dialog.

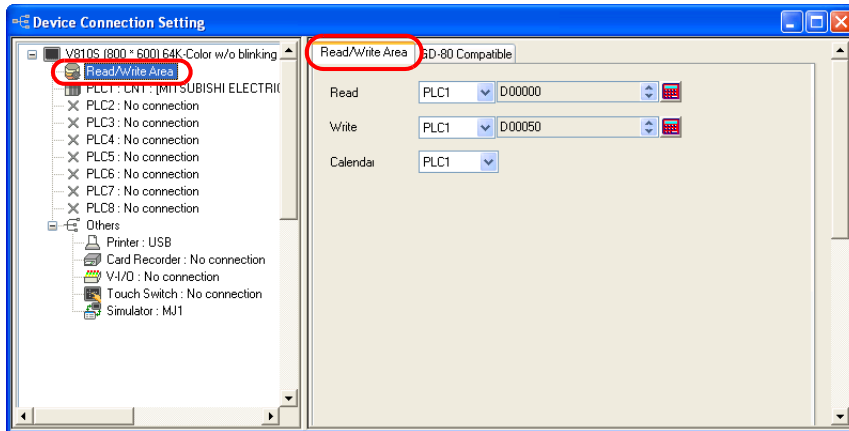

- For more details on the “read area” and “write area”, refer to “Chapter 1 System Setting” in the V8 Series Reference Manual.

For 2-way Connection

This section explains the setting procedure for connection to a V8 series unit with a device configuration like that shown below.

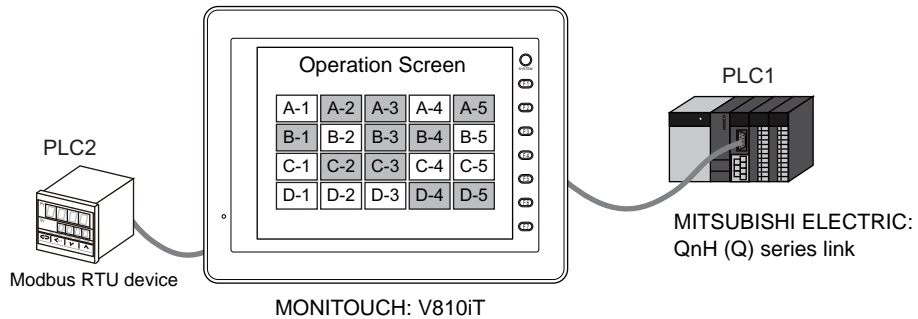

Setting Procedure

1. Select [New] from the [File] menu or click the [New] icon on the toolbar. The [Edit Model Selection] dialog is displayed.

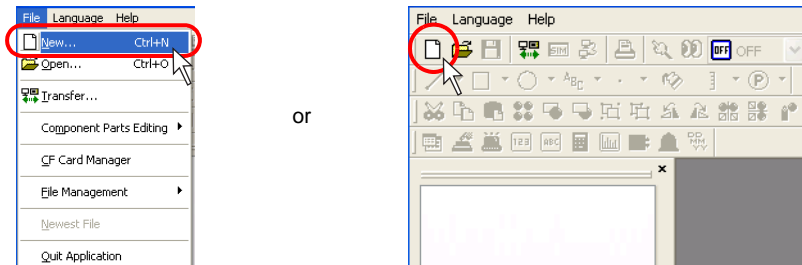

2. Select a model for [Edit Model]. In this example, we select "V810T". For [Color], select [64K-Color w/o blinking] and for [Touch switch] select [Analog Switch], then click [OK].

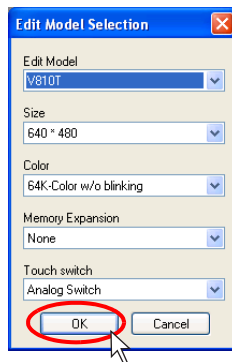

3. The [PLC1 Connection Device Selection] dialog is displayed.
Make settings as shown below.

Device: PLC
 Maker: MITSUBISHI ELECTRIC
 Series: QnH (Q) series link
 Connect to: CN1



4. On clicking [OK] the [Device Connection Setting] dialog starts up and you can check the settings for PLC1.

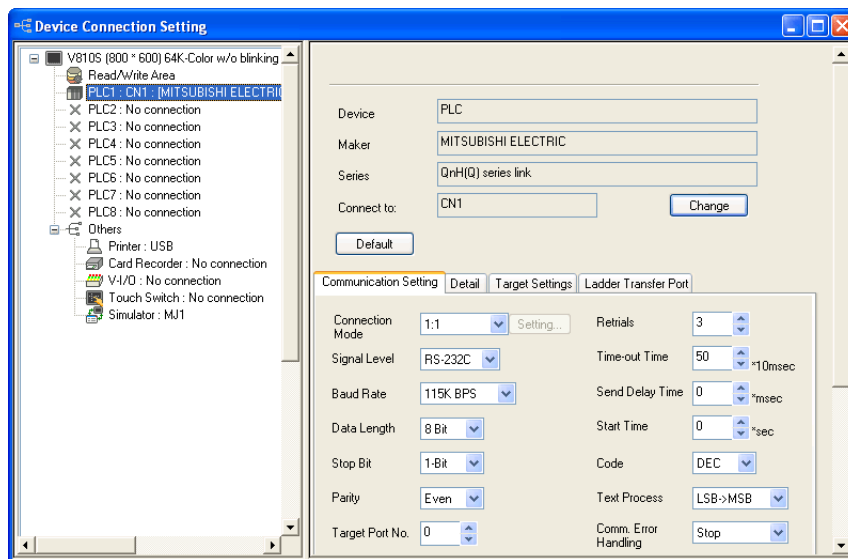

5. Set each of the parameter settings in the [Communication Setting] tab window so that they agree with those of the target PLC (in this example a “QnH (Q) series link” by MITSUBISHI).



If the settings at MONITOUCH don't agree with those at the PLC, [Communication Error PLC1 Time-Out] will be displayed at MONITOUCH and communications will not take place normally. Be sure to check the settings at both sides.

- Now make settings for PLC2.
Click [PLC2: No connection] in the [Device Connection Setting] dialog.
The option shown below appears in the dialog.

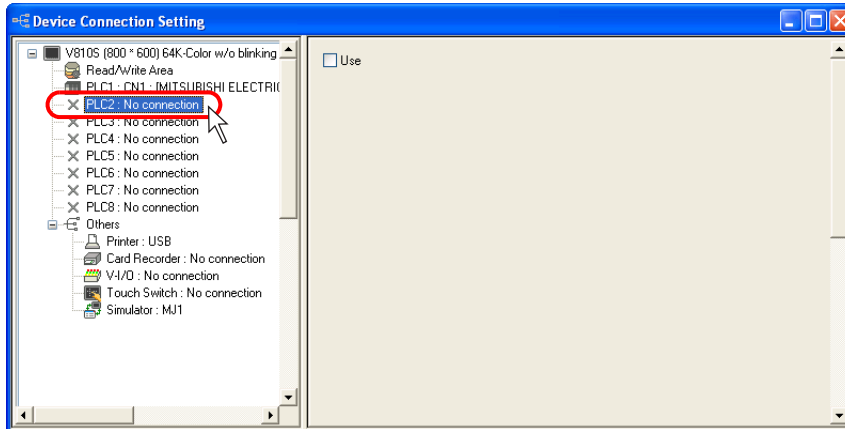

- Check the box for [Use].
Set [PLC] for [Device] and the default model will be set automatically.

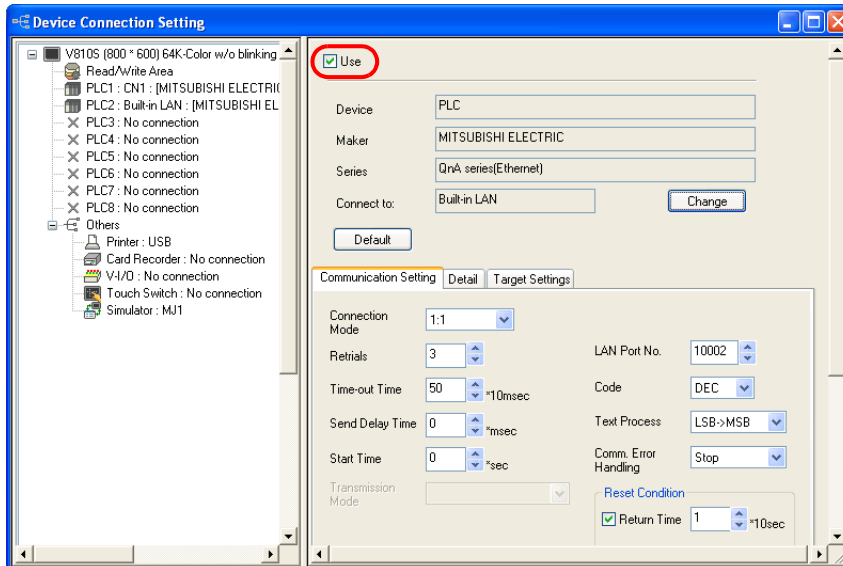

8. In this example, since a Modbus RTU-ready device is being connected [MODBUS RTU] has to be set for the [Series] selection.
First of all click the [Change] button.
The [PLC2 Connection Device Selection] dialog is displayed.

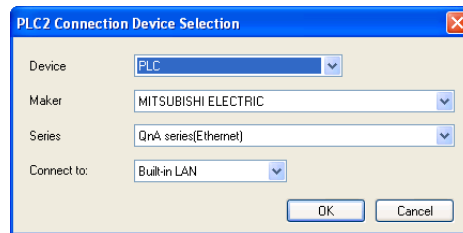
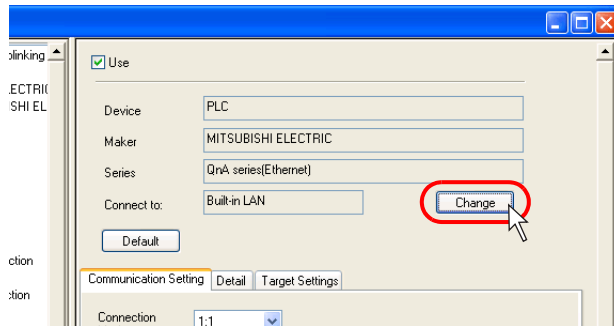

9. Check that [PLC] is set for [Device] and select [None] for [Maker].
Then select [MODBUS RTU] for [Series].

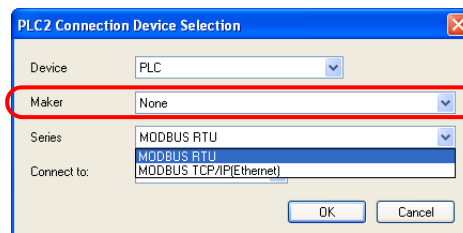

10. Select [MJ2] for [Connect to:].

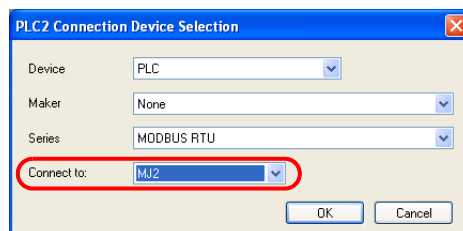

11. Click [OK].

The confirmation dialog shown below is displayed.

Click [Yes]: the question [Execute device conversion?] will appear.

Since we are adding PLC2 as a new device, click [No] here.

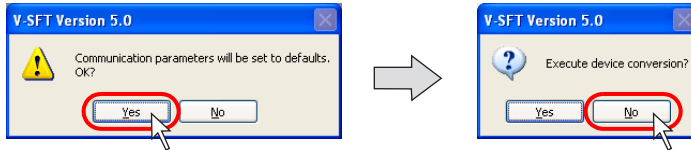

12. The settings in the [Device Connection Setting] dialog changes to those for Modbus RTU.

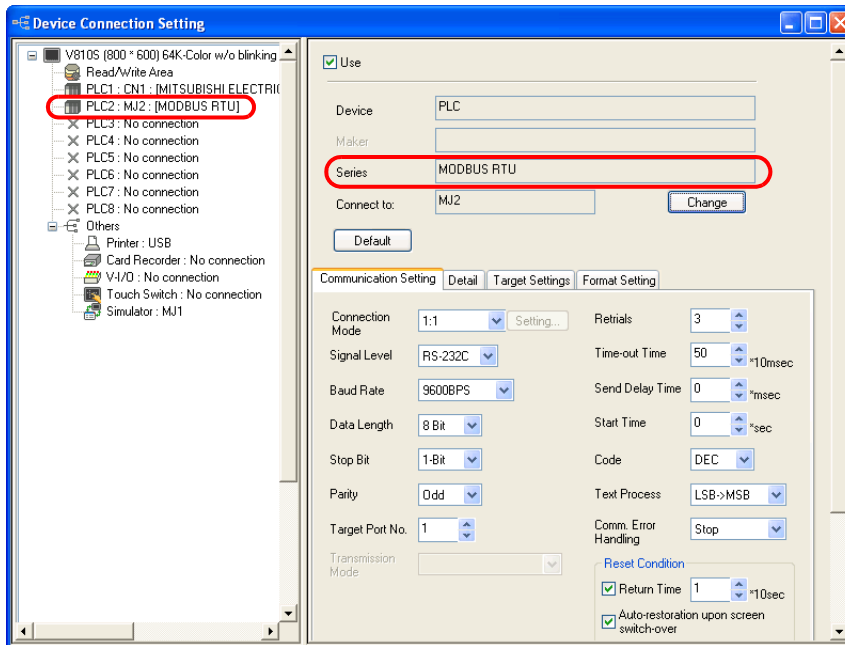

13. Set the parameters in the [Communication Setting] tab window so that they agree with the settings at the target Modbus RTU device.

14. Apart from this, when selecting [MODBUS RTU] you will have to define [Modbus Format Setting] in the [Format Setting] tab window.

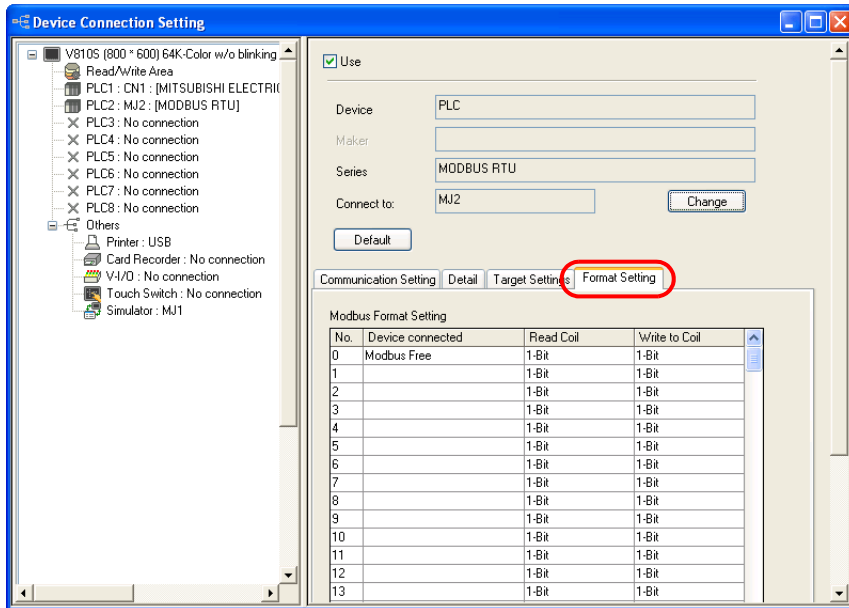

For details on the [Format Setting] tab window, refer to the V8 Series Connection Manual.

Read/Write Area Settings

- When creating a MONITOUCH screen data file, you must secure areas called the “read area” and “write area”. These areas can be set at addresses at PLC1, at addresses at PLC2, or in the MONITOUCH internal memory.
- The “read area” and “write area” settings are made on the [Device Connection Setting] dialog.

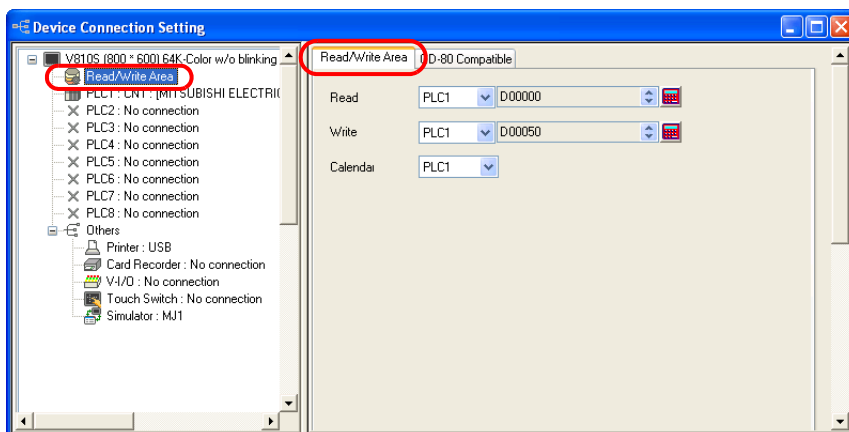

- For more details on the “read area” and “write area”, refer to “Chapter 1 System Setting” in the V8 Series Reference Manual.

About Device Memory Map

Overview

- You can set a “device memory map” for each of the connected devices, PLC1 to PLC8. Apart from reading data from the set memory onto the screen, this makes it possible to read and write values in another device or the MONITOUCH internal memory to and from each of the registered connected devices.

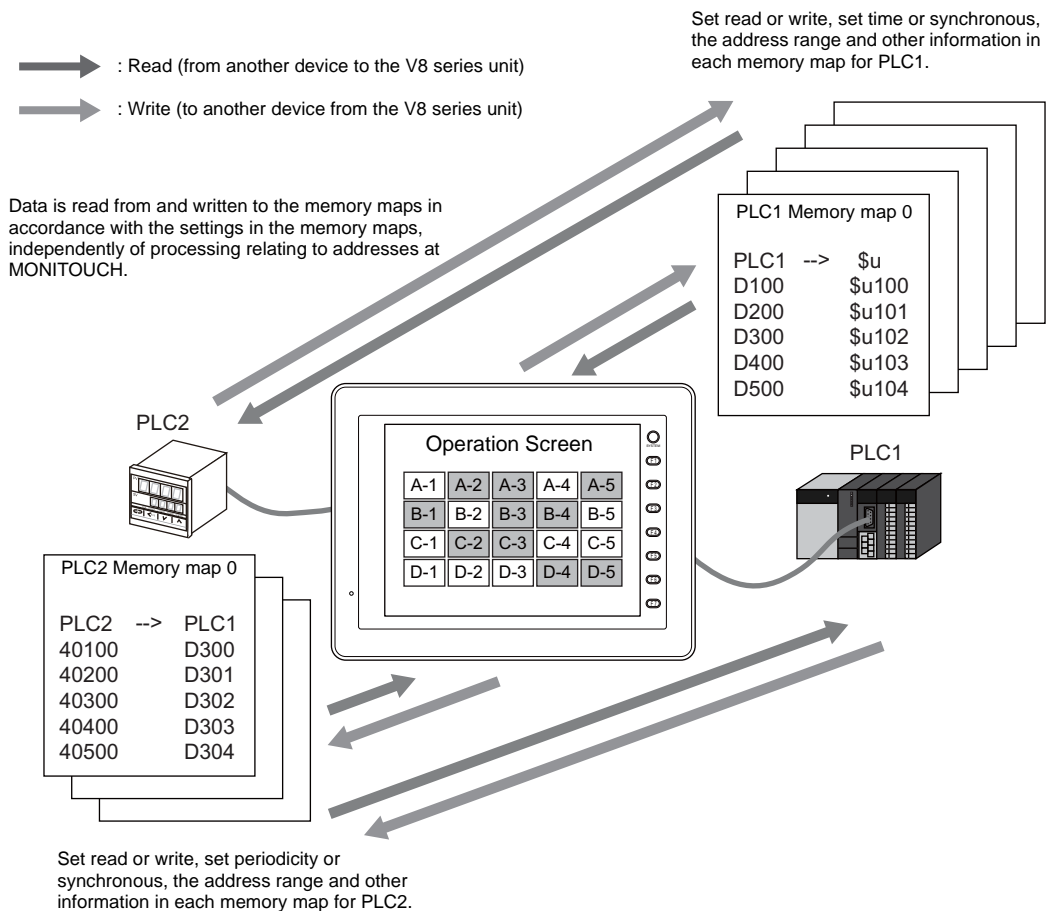

- By registering a “device memory map” you can efficiently read and write large volumes of data without imposing any load on the processing of items on the screen.

Setting Procedure

As an example we will explain here how to register device memory maps for PLC1 and PLC2 for screen data files with the 2-way setting.

1. In the dialog displayed by selecting [System Setting] → [Device Connection Setting], check that settings have been made for [PLC1] and [PLC2].
(In this example, [MITSUBISHI ELECTRIC: QnH (Q) series link] is set for PLC1, and [MODBUS RTU] is set for PLC2.)

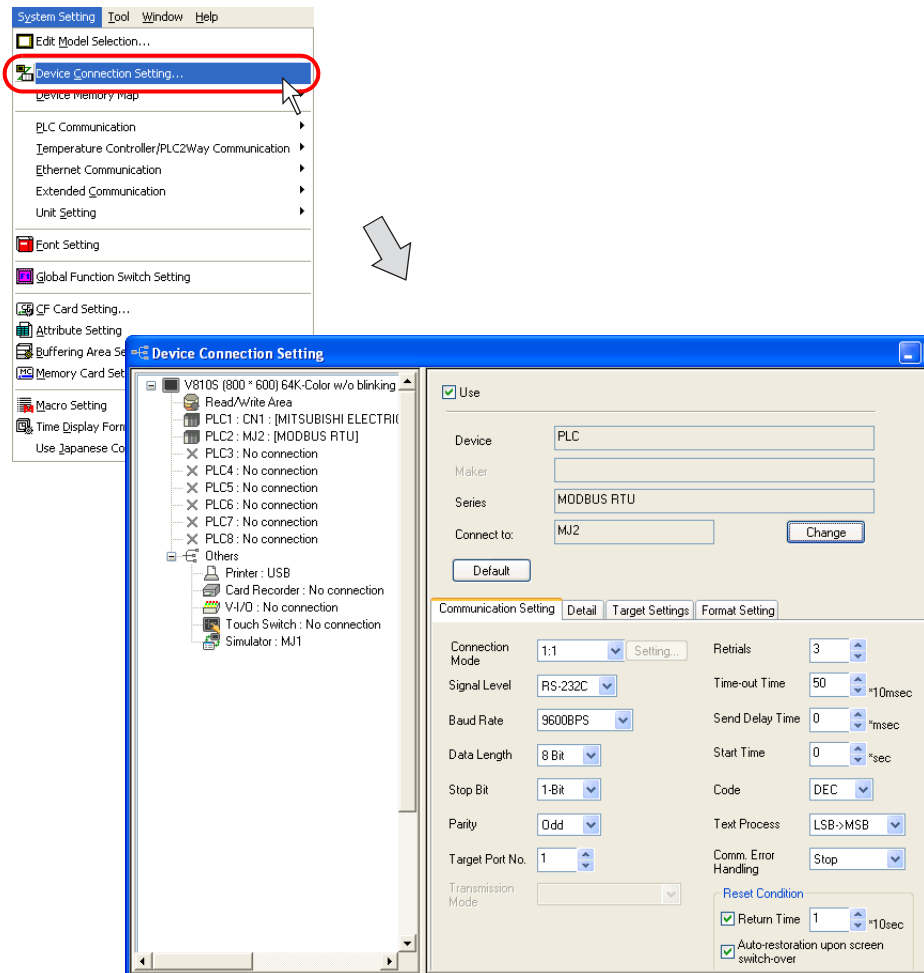

3.3 Setting Example

2. Move the mouse cursor onto [System Setting] → [Device Memory Map] and a menu in which [PLC1] and [PLC2] are valid will be displayed.

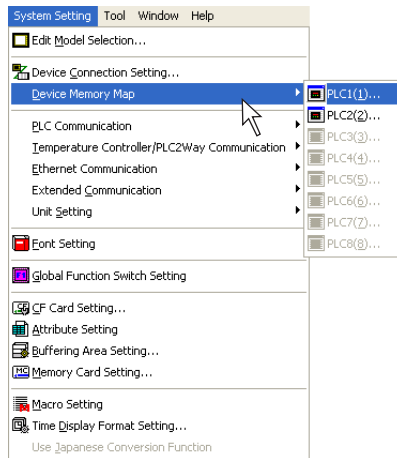

3. Firstly, register the device memory map for PLC1. Click [System Setting] → [Device Memory Map] → [PLC1]. The following dialog is displayed.

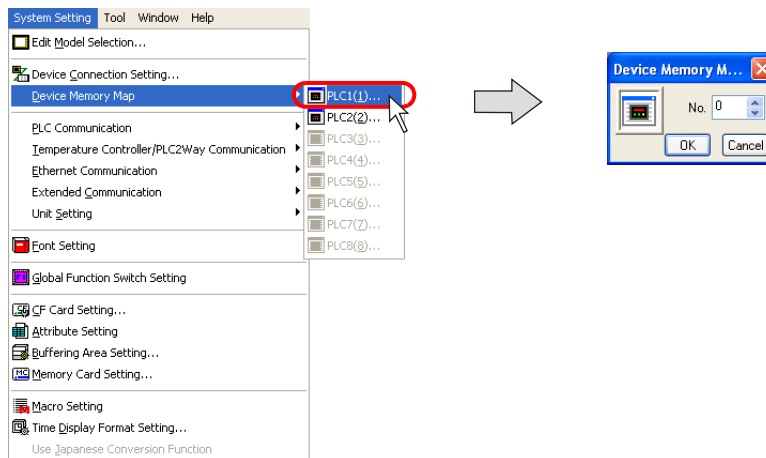

4. Check that "0" is set for [No.] and click [OK].
The [Device Memory Map: PLC1[0] Edit] window is displayed.

No.	PLC1 Memory	Name	Data Type	>> Target Memory 1	>> Target Memory 2
0					
1					
2					
3					
4					
5					
6					
7					
8					
9					
10					
11					
12					
13					
14					
15					
16					
17					
18					
19					

5. As an example, we will make settings for table No. 0 such that values are written periodically from an address at PLC1 to the MONITOUCH internal memory. In the left-most column, set the address at PLC1.
Set five words of data as shown below.

- No. 0: D100 (word)
No. 1: D200 (word)
No. 2: D300 (word)
No. 3: D400 (word)
No. 4: D500 (word)

No.	PLC1 Memory	Name	Data Type	>> Target Memory 1	>> Target Memory 2
0	D00100		Word	001601	\$u00100
1	D00200		Word	001617	\$u00101
2	D00300		Word	001633	\$u00102
3	D00400		Word	001649	\$u00103
4	D00500		Word	001665	\$u00104
5					
6					
7					
8					

6. Next, select "Periodical Reading" for table No. 0.
Either double click [>> Target Memory] in the title line, or select [Edit] → [Device Memory Map Setting].

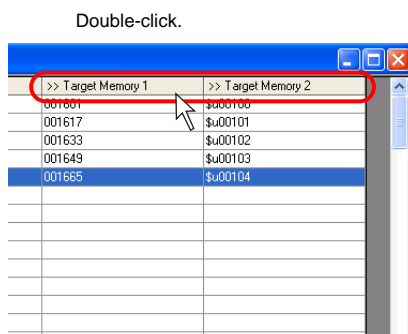

OR

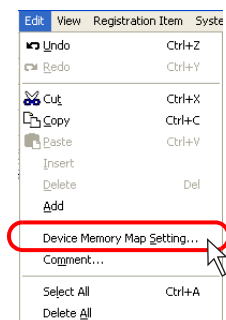

7. The [Device Memory Map Setting] dialog for table No. 0 is displayed.

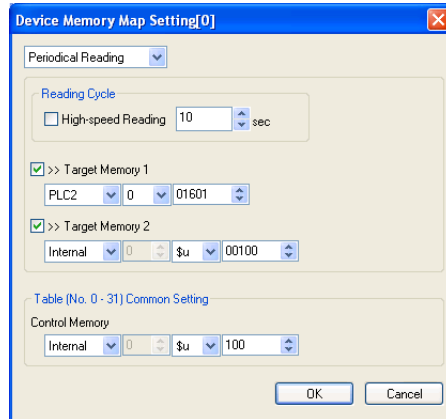

8. Set as shown below.

- Function: Periodical Reading
- Reading Cycle: 3 (sec)
- >> Target Memory 1: Unchecked
- >> Target Memory 2: Checked
- Internal Memory: \$u100
- Control Memory: \$u200

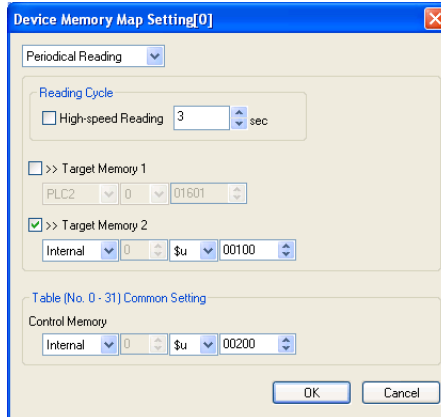

When settings has been made, click [OK].

9. Now start device memory map setting for PLC2.
Click [System Setting] → [Device Memory Map] → [PLC2].
The following dialog is displayed.

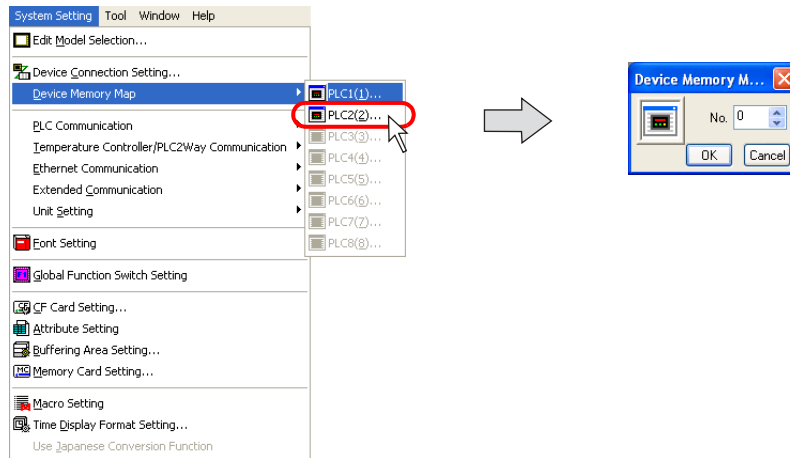

10. Check that "0" is set for [No.] and click [OK].
The [Device Memory Map: PLC2 [0] Edit] window is displayed.

No.	PLC2 Memory	Name	Data Type	>> Target Memory 1	>> Target Memory 2
0					
1					
2					
3					
4					
5					
6					
7					
8					
9					
10					
11					
12					
13					
14					
15					
16					
17					
18					
19					
20					

11. This time we will make the setting to read data from an address in PLC2 to an address in PLC1. In the left-most column, set the address at PLC2. Set five words of data as shown below.

- No. 0: 40100 (word)
- No. 1: 40200 (word)
- No. 2: 40300 (word)
- No. 3: 40400 (word)
- No. 4: 40500 (word)

No.	PLC2 Memory	Name	Data Type	>> Target Memory 1	>> Target Memory 2
0	400101		Word	D00100	\$u00100
1	400200		Word	D00101	\$u00101
2	400300		Word	D00102	\$u00102
3	400400		Word	D00103	\$u00103
4	400500		Word	D00104	\$u00104
5					
6					
7					

12. Next, select "Periodical Reading" for table No. 0. Either double click [>> Target Memory] in the title line, or select [Edit] → [Device Memory Map Setting].

Double-click.

OR

13. The [Device Memory Map Setting] dialog for table No. 0 is displayed.

14. Make settings as shown below.

Function: Periodical Reading
 Reading Cycle: 5 (sec)
 >> Target Memory 1: Checked
 PLC1 memory: D300
 >> Target Memory 2: Unchecked
 Control Memory: \$u300

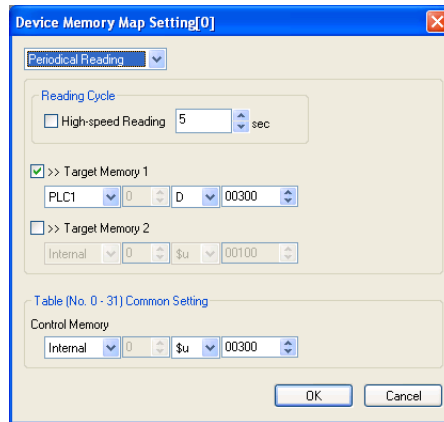

When settings has been made, click [OK].

Guide to operations

The setting operations involved in the examples given above are summarized in the figure below.

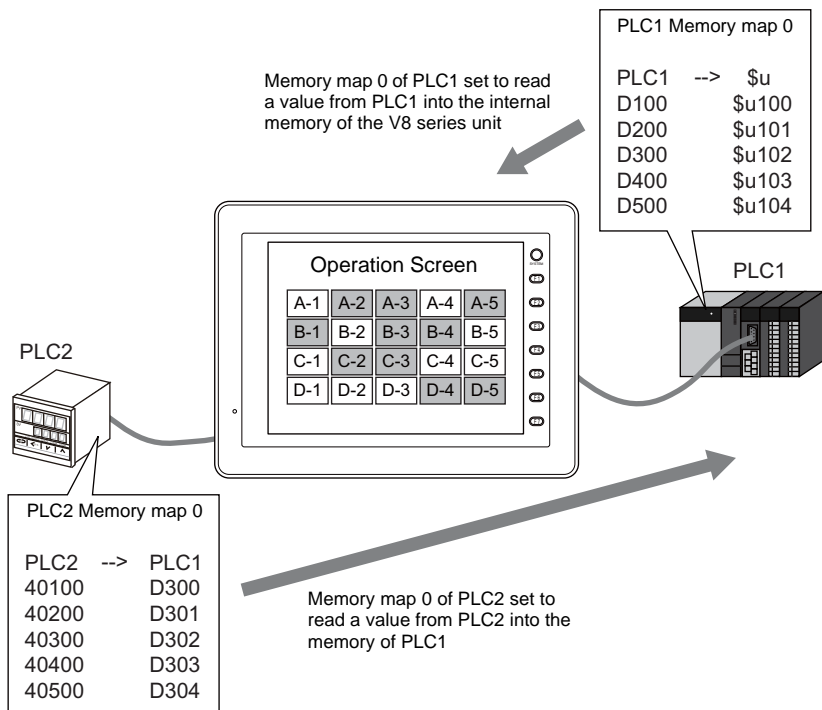

MEMO



Please use this page freely.

4 Screen Editing

4.1 Editing Procedure

The flow of the operations from creating a new screen data to transferring it to MONITOUCH is shown below.

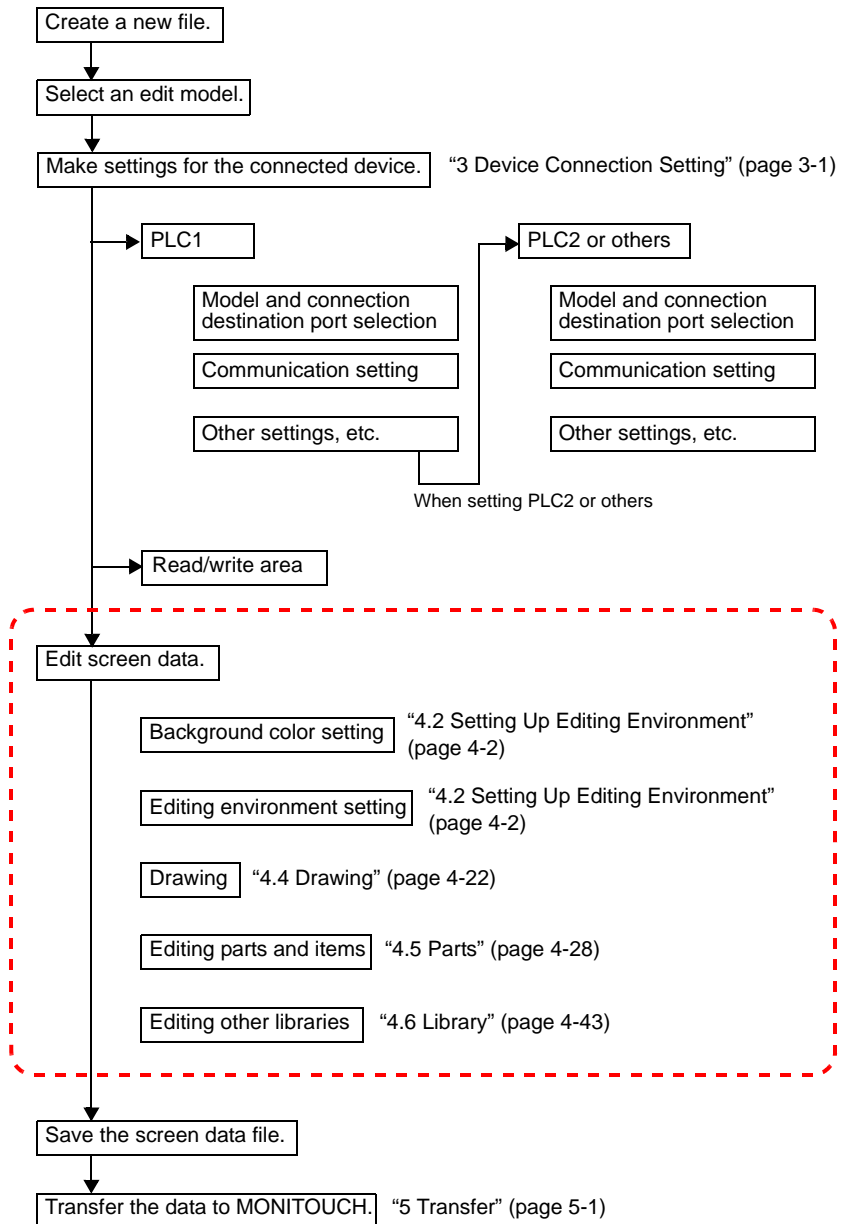

This chapter gives a detailed explanation of the setting procedure inside the dotted line frame in the figure above.

4.2 Setting Up Editing Environment

Background Color Setting

Follow the procedure shown below to change the screen background color during screen editing.

1. Click [Screen Setting] → [Screen Setting].
The [Screen Setting] dialog is displayed.

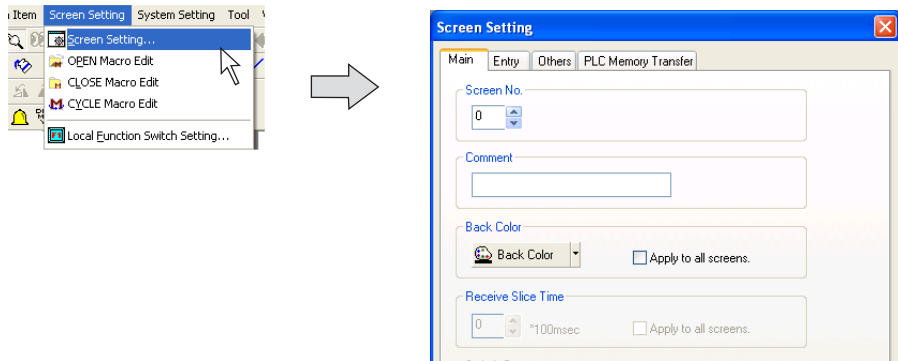

2. Click the [Back Color] button. The pull-down menu for selecting color is displayed.
Select a background color as desired.

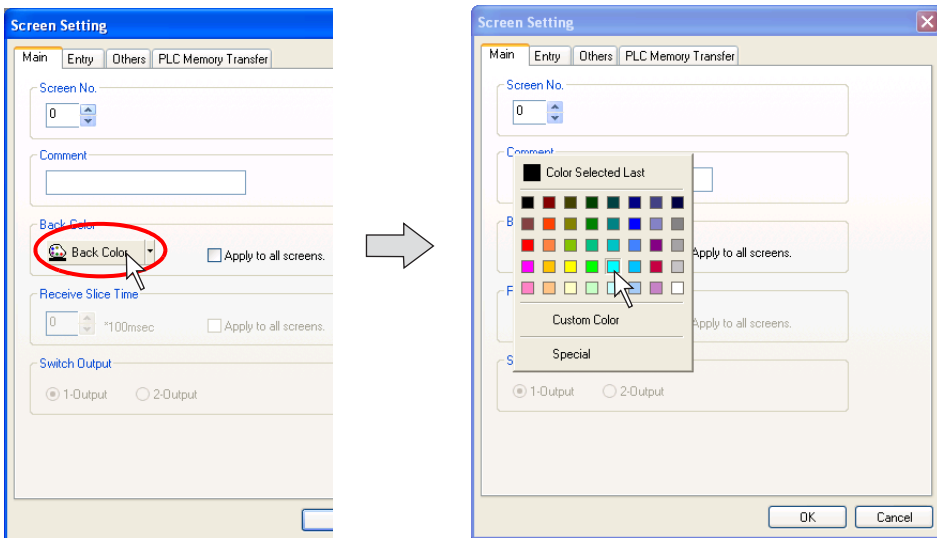

3. The selected color is displayed on the icon.

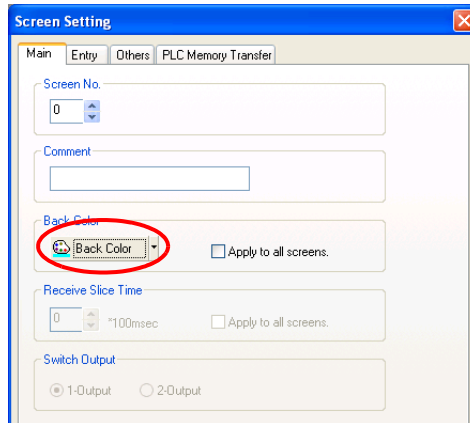

If you want to select any color other than colors listed in the pull-down menu, click [Custom Color] in the menu. The [Custom Color] dialog is displayed.

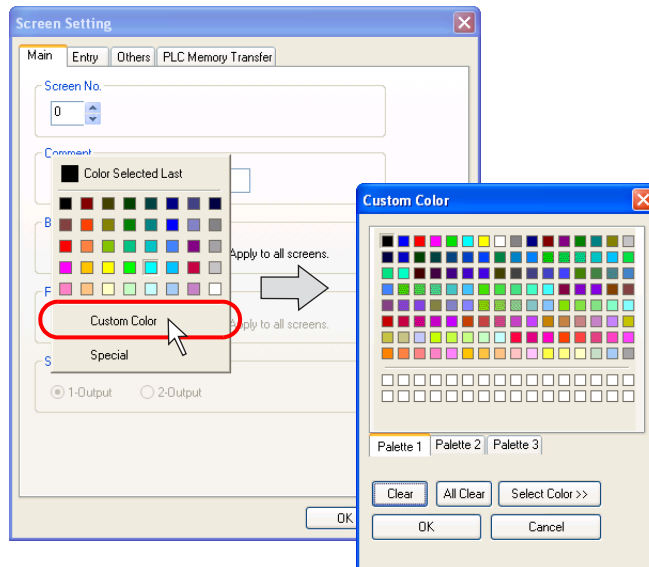

Select a color as desired.

Grid Setting

What Is Grid?

“Grid” is used as a guide when graphics or parts are placed. This is not displayed on MONITOUCH, but displayed on the editor only.

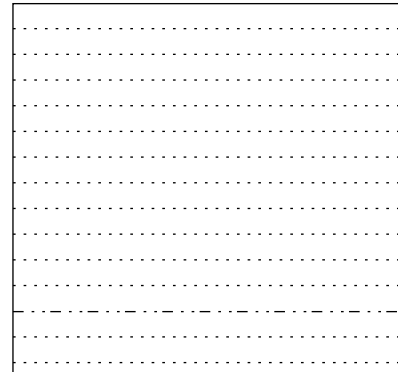
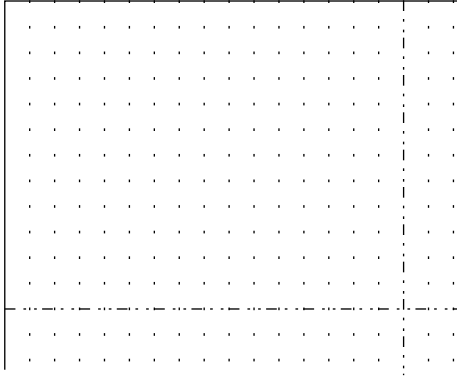

Grid Setting

Click [View] → [Grid], or right-click the mouse and click [Grid].

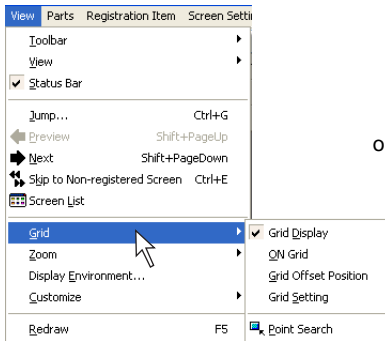

OR

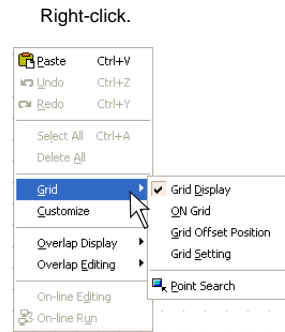

Grid Display	Shows grids when this option is checked. Unchecking this option clears grids from the screen.
ON Grid	When this option is checked, items are moved or changed based on the grid. ("ON Grid" is not valid for overlap displays.)

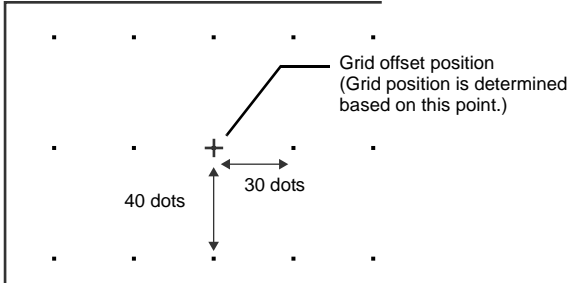
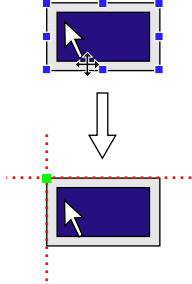
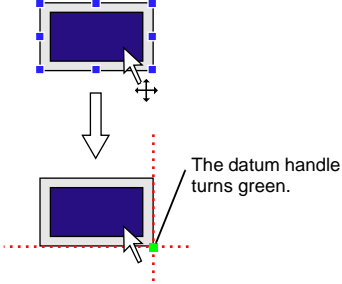
<p>Grid Offset Position</p>	<p>This option is valid when [Free] is chosen for [Grid Type]. When this option is checked, the grid offset position is determined by clicking the desired position on the screen.</p> <p>Example: X pitch: 30, Y pitch: 40</p> 
<p>Grid Setting</p>	<p>Clicking this option brings up the [Grid Setting] dialog. For more information on the [Grid Setting] dialog, see the next page.</p>
<p>Point Search</p>	<p>When this option is checked, the handle closest the dragged point becomes the datum point.</p> <div style="display: flex; justify-content: space-around;"> <div style="text-align: center;"> <p>By dragging at the upper left:</p>  <p>Upper left handle becomes datum point.</p> </div> <div style="text-align: center;"> <p>By dragging at the lower right:</p>  <p>Lower right handle becomes datum point.</p> </div> </div>

[Grid Setting] dialog

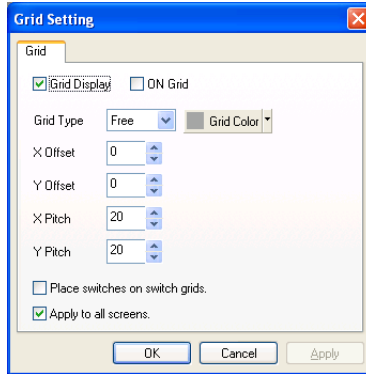

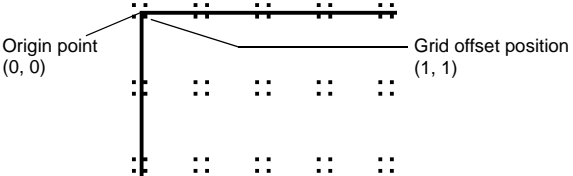
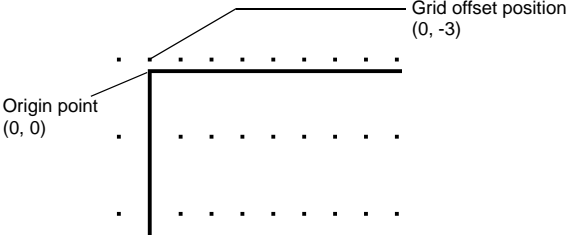
<input type="checkbox"/> Grid Display	Shows grids when this option is checked. Unchecking this option clears grids from the screen.
<input type="checkbox"/> ON Grid	When this option is checked, items are moved or changed based on the grid. ("ON Grid" is not valid for overlap displays.)
Grid Type (Free/Switch/1-Byte/Mode)	Selects the grid type. Free: You can freely set a desired grid. Switch: This grid is used for the matrix type switch. The grid is based on the unit: 16 × 20 dots (the unit of switch: 14 × 18 dots plus spaces: 2 × 2 dots). The datum point is placed at the coordinates (1, 1).  1-Byte: The grids are based on the unit: 8 × 20 (the unit of one-byte character: 8 × 16 dots plus four Y-axis dots). The datum point is placed at the coordinates (0, -3). 

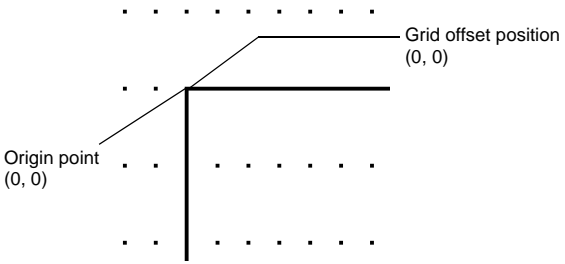
	<p>Mode: The mode grid is equivalent to the one-byte character grids, but its offset position differs. The mode grid is based on the unit: 8 × 20 dots. The datum point is placed at the origin point (0, 0). Lines and columns are used to indicate item positions.</p> 
Grid Color	Select the desired grid color.
X Offset * ¹ Y Offset	<p>This option is active when [Free] is chosen for [Grid Type]. Specify the offset coordinate. * The offset coordinate can be specified by right-clicking and clicking [Grid] → [Grid Offset Position].</p>
X Pitch * ¹ Y Pitch	<p>This option is active when [Free] is chosen for [Grid Type]. Specify the pitch.</p>
<input type="checkbox"/> Place switches on switch grids.	When this option is checked, switches are moved or changed based on the switch grid, irrespective of the grid setting.
<input type="checkbox"/> Apply to all screens.	When this option is checked, the grid settings are applied to all screen editing windows.

*1 Relation between “offset” and “pitch”

Grids are placed from the offset point at intervals specified by X and Y pitches as shown in the examples below.

Ex. 1)
[X Offset: 0]
[Y Offset: 0]
[X Pitch: 20]
[Y Pitch: 20]

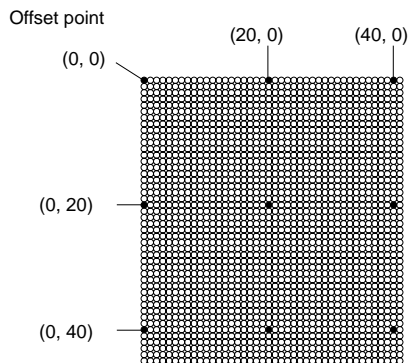

Ex. 2)
[X Offset: 10]
[Y Offset: 10]
[X Pitch: 20]
[Y Pitch: 20]

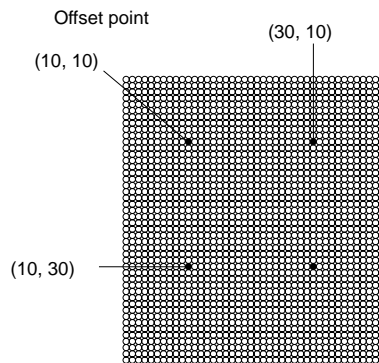

Display Environment Setting

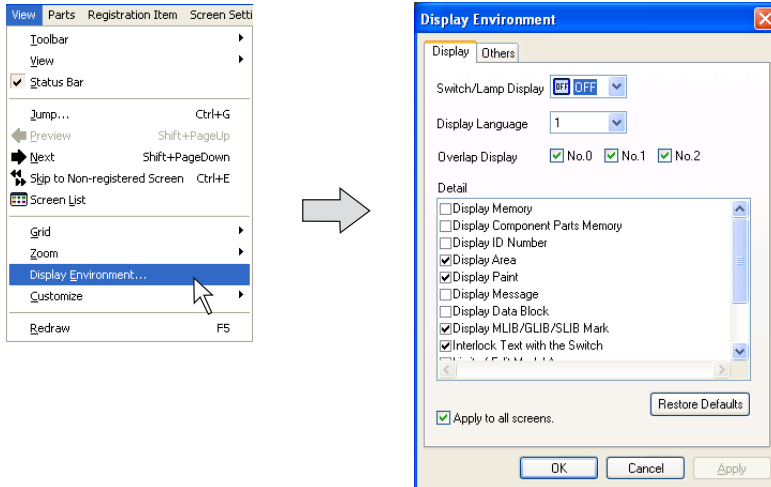

The display environment on the screen can be set all at once.

Click [View] → [Display Environment]. The [Display Environment] dialog is displayed.

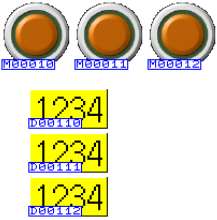

[Display] Tab Window

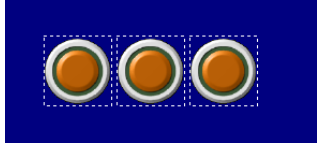
Switch/Lamp Display		Select from [ON], [OFF], and [P3] - [P16] for the status of the switches or lamps displayed on the screen. * Can also be selected on the [Standard] toolbar.
Display Language		This option is used to change the interface language. Select from [1] to [8] to change the language displayed on the screen. * Can be selected on the [Multi-language] toolbar.
Overlap Display		Select whether or not to display each overlap display part. * Can also be selected from the right-click menu or on the [Overlap] toolbar.
Detail	<input type="checkbox"/> Display Memory	When this option is checked, the memory set for each item is displayed. 
	<input type="checkbox"/> Display Component Parts Memory	This option is valid for component parts only. When this option is checked, the memory set for each component part is displayed.

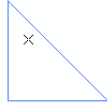
	<input type="checkbox"/> Display ID Number	<p>When this option is checked, the ID number of each part is displayed.</p> 
	<input type="checkbox"/> Display Area	<p>When this option is checked, the area of each part is displayed with dotted lines.</p> 
	<input type="checkbox"/> Display Paint	<p>When this option is checked, the graphic drawn with the [Paint] icon is displayed as painted. When this option is unchecked, [x] is displayed as the paint start point.</p> <p>When checked:  When unchecked: </p>
	<input type="checkbox"/> Display Message	<p>When this option is checked, messages set for bit order alarming/message (applicable only when [Block] or [Internal Command] is set)/alarm tracking are displayed on the screen.</p>
	<input type="checkbox"/> Display Data Block	<p>This option is valid only when a data block area is set on the screen. When this option is checked, contents registered in the data block area are displayed on the screen.</p>
	<input type="checkbox"/> Display Offset Mark	<p>This option is valid only for the graphic library or data block area. When this option is checked, the offset mark is displayed.</p>
	<input type="checkbox"/> Display MLIB/GLIB/SLIB Mark	<p>When this option is checked, the MLIB (overlap library) mark, GLIB (graphic library) mark and SLIB (screen library) mark are displayed.</p>
	<input type="checkbox"/> Display in Monochrome 8-tone Colors	<p>This option is valid on monochrome-type MONITOUCH. When this option is checked, the colors on the screen are displayed in the monochrome 8-gradation colors.</p>
	<input type="checkbox"/> Interlock Text with the Switch	<p>When a switch part or lamp part is enlarged/reduced in size while this option is checked, the text on the switch part or the lamp part is also enlarged/reduced.</p>
	<input type="checkbox"/> Limit of Edit Model Area	<p>When this option is unchecked, an item can be placed at the right or bottom in the marginal area. When this option is checked, an item can only be placed within the area available for the edit model.</p>
	<input type="checkbox"/> Display Animation Path	<p>This option is valid only for animation graphics. When this option is checked, the path of animated graphic is depicted.</p>
	<input type="checkbox"/> Display Center Line	<p>When this option is checked, the center line is displayed.</p>

	<input type="checkbox"/> Display Component Parts Icon	When this option is checked, the component parts icon is displayed.
<input type="checkbox"/> Apply to all screens.		When this option is unchecked, the display environment setting is only applied to the current screen. When this option is checked, the setting is applied to all screens.

[Others] Tab Window

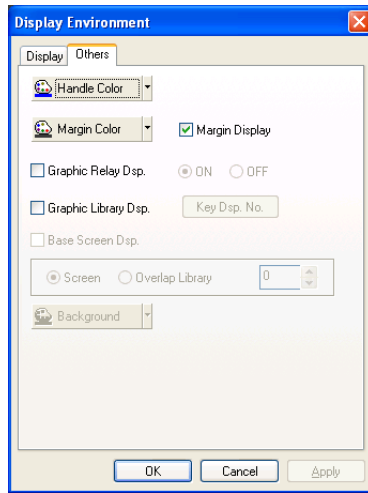

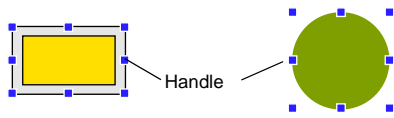
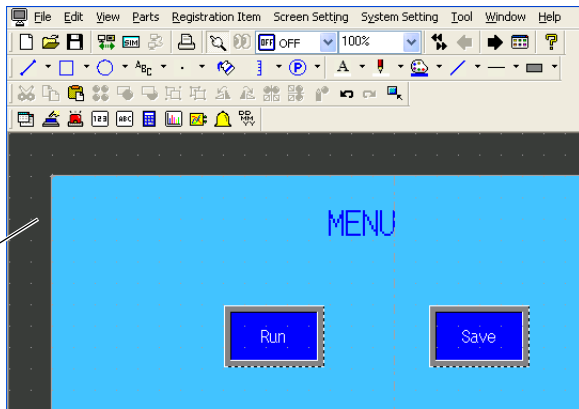
Handle Color	When an item is selected, handles are displayed around it. Set the color of these handles here. 
Margin Color	Select a marginal color around the editing area. 

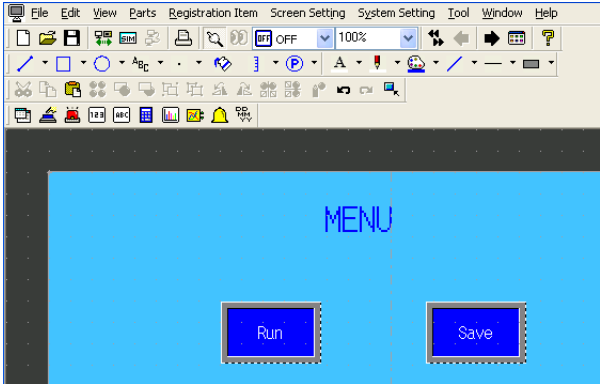
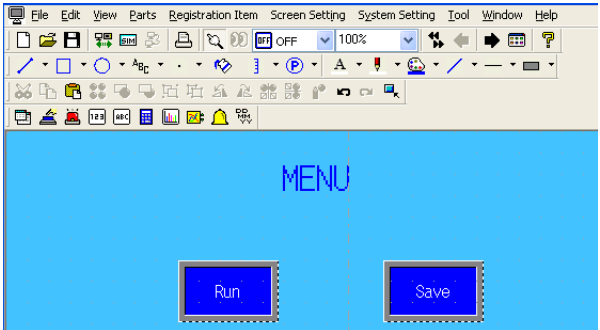
<input type="checkbox"/> Margin Display	<p>When this option is checked, the space (margin) is created at the left and the upper side of the editing area with the color set for [Background]. If you uncheck this option, the margin area disappears.</p> <p>When checked:</p>  <p>When unchecked:</p> 
<input type="checkbox"/> Graphic Relay Dsp.	<p>This option is valid only for the graphic relay display. When this option is checked, the ON/OFF status in the graphic relay display can be checked.</p>
<input type="checkbox"/> Graphic Library Dsp.	<p>This option is valid when the entry mode display or the graphic display is set. For the entry mode display, this option is enabled when <input type="checkbox"/> [Graphic] is checked. When [Graphic] is checked, graphics registered in the graphic library can be displayed on the character entry key. For the graphic display, graphics can be displayed on the screen provided that [Internal] is chosen for [Designate].</p>
<input type="checkbox"/> Base Screen Dsp.	<p>This option is valid during editing of the graphic library, overlap library, or data block. When this option is checked, a screen or overlap library is displayed on the editing window.</p>
Background	<p>This option is valid during editing of the graphic library, overlap library, or data block. Select the background color of the editing window.</p>

4.3 Setting Menus

There are several types of setting menus on the list-view window or dialog of the editor. This section provides some examples of these menu types.

Menu Types

Pull-down Type

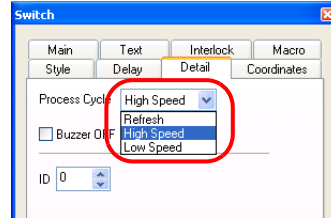
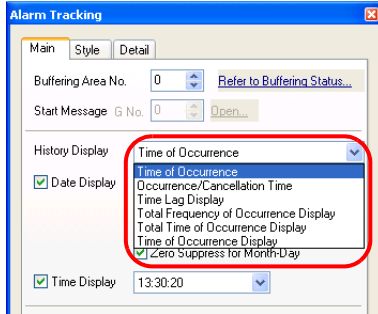

- Click the arrow button or item itself to bring up the pull-down menu.
- Click the desired item and then click [OK].
- In the case of the pull-down menu for zoom, you can directly enter the zooming factor in the field.

Select from the pull-down menu.

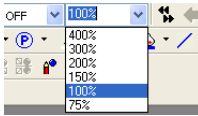

or

Enter the desired value directly.

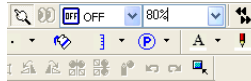

Option Button

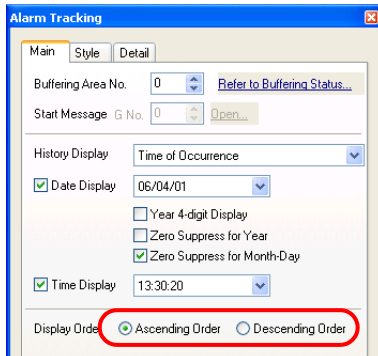

- This button is used when there are two or three choices.

Numerical Data Entry Box Type



- Change the value using the up/down arrow buttons.
- You can also enter the value in the field directly.

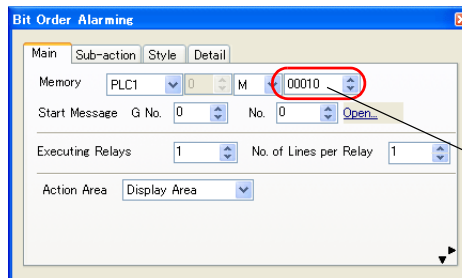

Enter the desired value directly.

Check Box

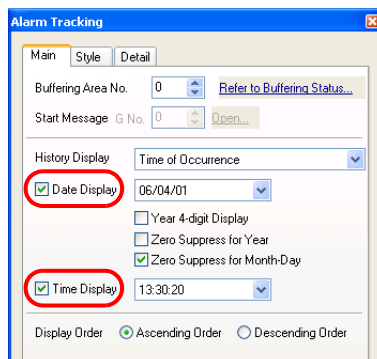

- Clicking the box brings up a check mark, and the setting becomes enabled.

List Type

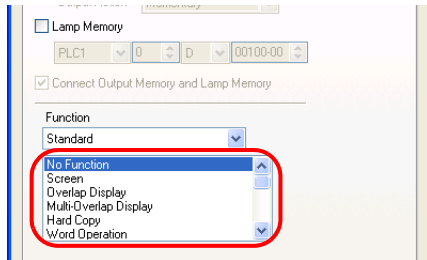

- By clicking the item in the list, it is highlighted. This denotes that the item is selected.
- If some options are hidden, you can bring them up using the scroll bar.

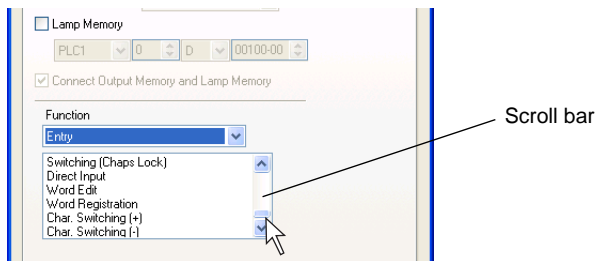

Command Button

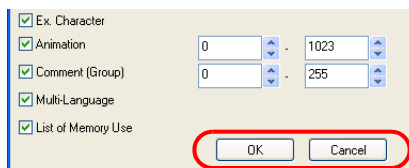
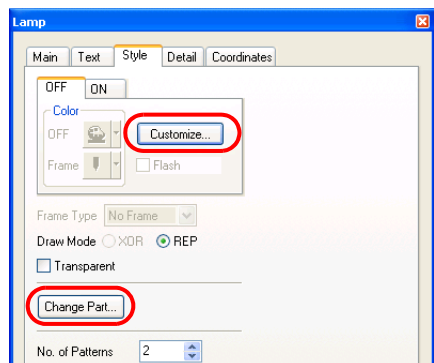
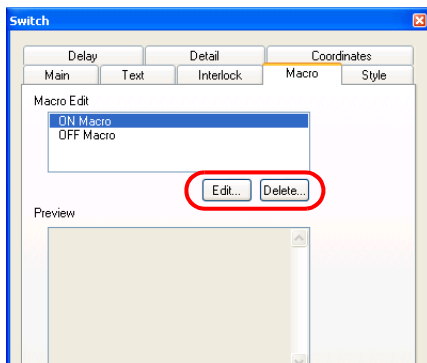

- Clicking the command button moves to the next editing window or closes the current editing.

Underlined Type for Numerical Data Entry

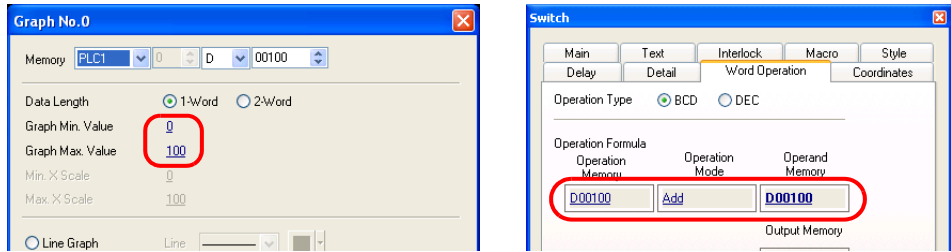

- Clicking the underlined data brings up the data entry field. Enter the desired value in the field.

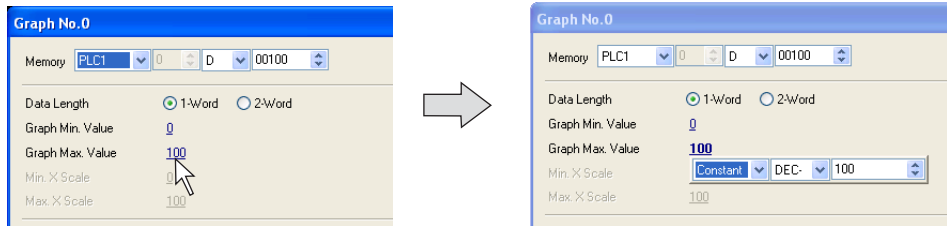

Click.

Underlined Type for Selection

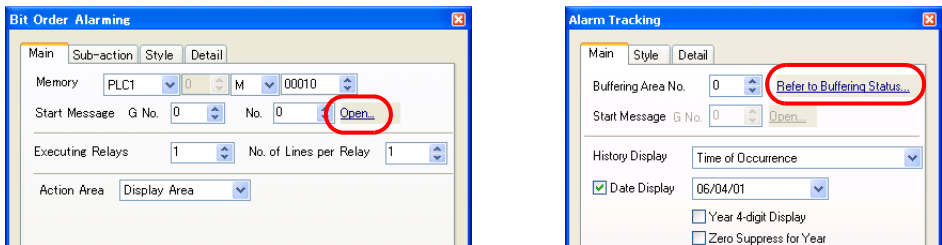

- Clicking the option jumps to the corresponding setting menu or editing area.

Memory Setting

Memory addresses allocated to lamp parts, numerical data display, etc., or read area and write area used to monitor or control the screen displayed on MONITOUCH, is defined in the memory setting menu. There are several types of menus for memory setting.

Entry Types

Normal display type

The figure below shows the normal type.

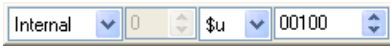

You can select the memory type and address type from the pull-down menu.

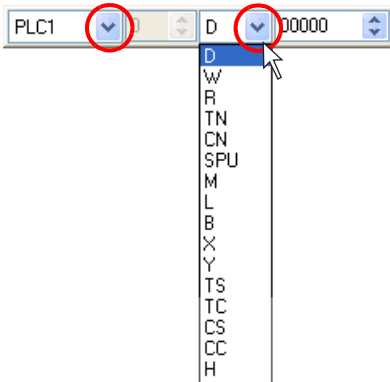

Change the value using the up/down arrow button or enter the desired value in the field directly.

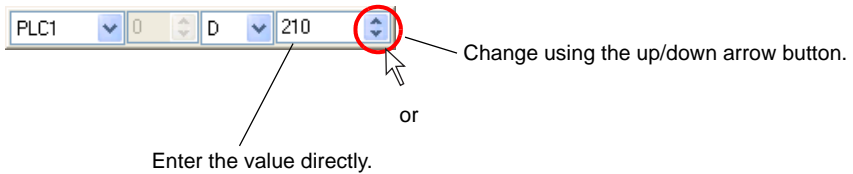

Simple display type

The figure below shows the normal type.

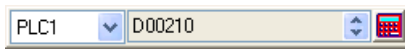

Click the calculator icon. The [Memory Input] dialog is displayed.
Specify the desired memory address here.

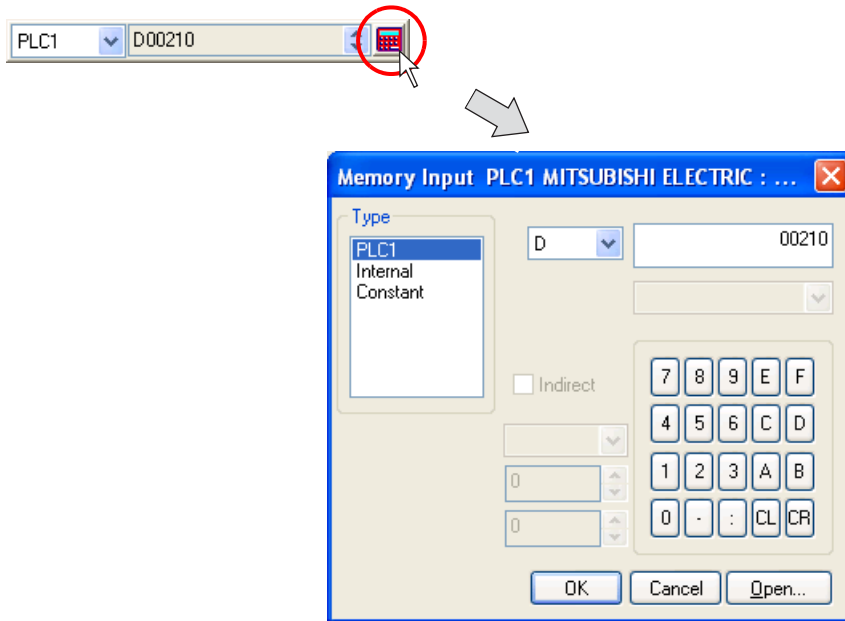

- * You cannot enter the value directly in the numerical data field.
However, when the up/down arrow button is shown, you can select the value using the arrow button.

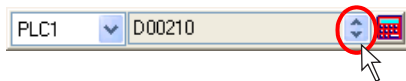



How to select the entry method:

To change the entry method between the normal display type and simple display type, right-click the mouse close to the memory type field.

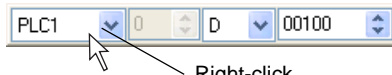

The display types are shown in the pull-down menu. Select the desired type.

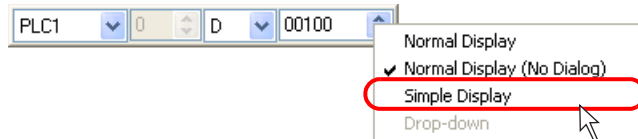

Click [Simple Display].



The display is changed to the simple display.

[Normal Type] provided here denotes [Normal Type (No Dialog)].
When [Normal Display] is selected, the appearance is the same as [Normal Display (No Dialog)]; however, [Memory Input] dialog appears every time the value is changed.

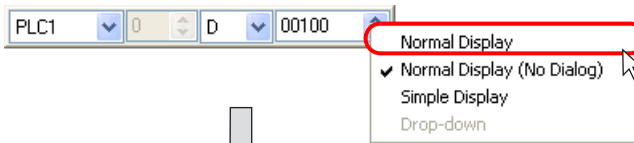

When [Normal Display] is selected:



Click.

[Memory Input] dialog is displayed each time you click.

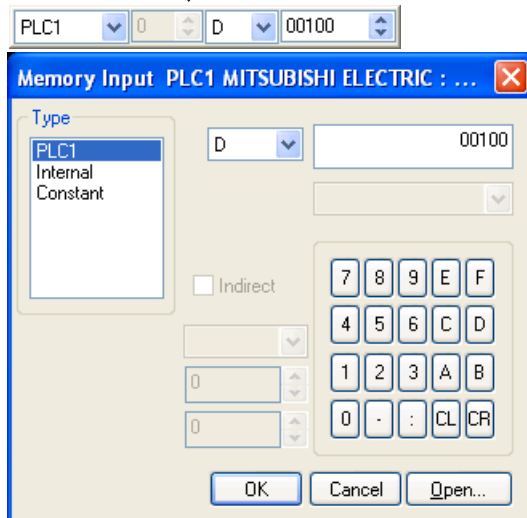

Memory Types

PLC1 memory to PLC8 memory

Set the memories of the connected PLC(s), PLC1 to PLC8.

Ex.) MITSUBISHI [A series link] (1:1)

Ex.) Yokogawa [FA-M3] (1:1)

Ex.) MITSUBISHI [A series link] (1:n)

1. CPU No.	This field becomes active when [Yokogawa: FA-M3], etc. is selected.
2. Port number	This field becomes active when "1:n" communication is selected.

Internal memory

Set the memory address range to be set in MONITOUCH.

User memory	\$u	For more details on the definition or range of the internal memory, see "Appendix 6 Internal Memory" in the V8 Series Reference Manual.
	\$L/\$LD (non-volatile)	
	\$T (per screen)	
	\$M/\$MC (macro)	
	\$C (component)	
System memory	\$s	
	\$P	

Memory where an address list exists

If a temperature controller or inverter has been selected, it is indicated as shown below.

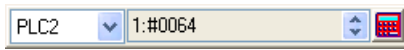

Click the calculator icon. The [Memory Input] dialog is displayed.

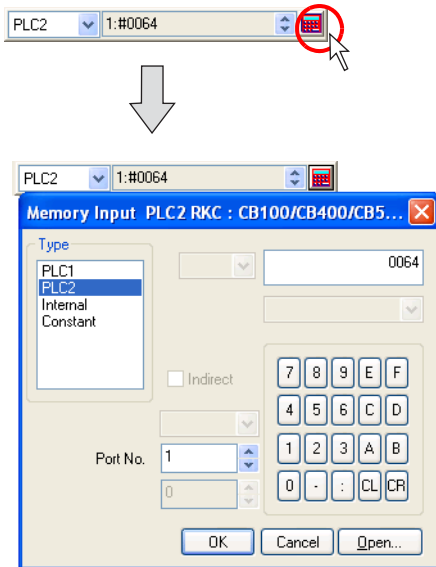

Clicking the [Open] button brings up the address list of the selected temperature controller.

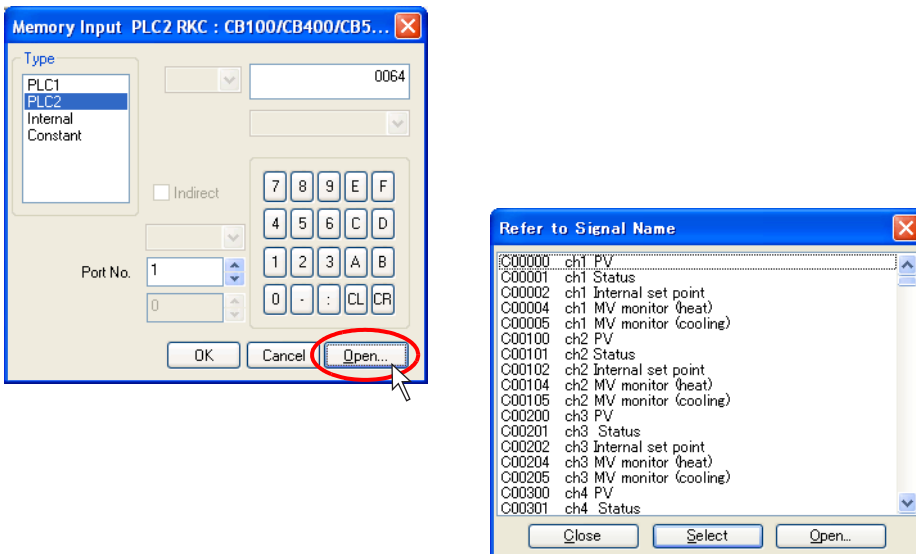

Select the desired address and click the [Select] button. The memory address is set and the former setting dialog is displayed again.

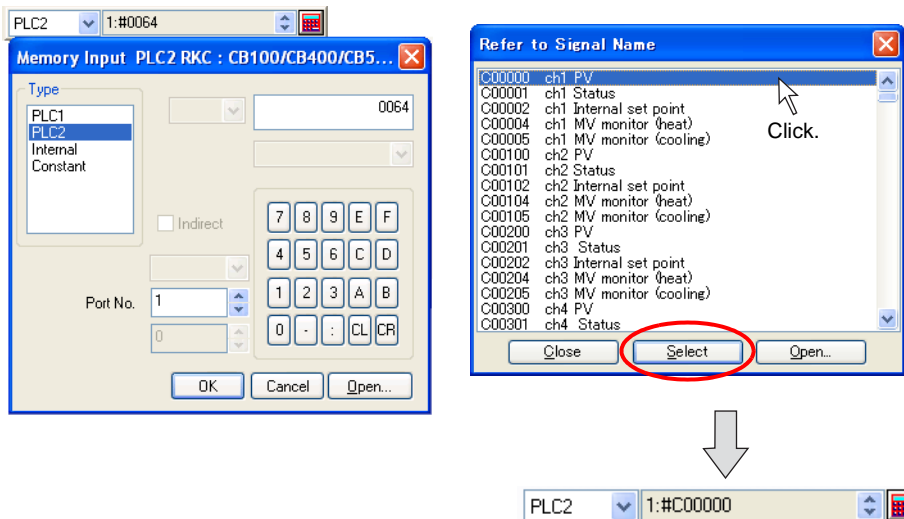

The selected address is displayed.

Memory card

This memory is available when [Data File] is selected for [Type] in the [Memory Card Setting] dialog ([System Setting] → [Memory Card Setting]).

Specify the file number, record number and address for data in the record.

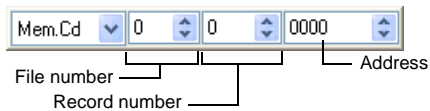

4.4 Drawing

Drawing Toolbar

How to Display

Displaying the drawing toolbar is required when using the drawing function. The toolbar is displayed at the first start-up.

When the toolbar is not visible previously, it will not be displayed at the next start-up.

In this case, bring up the toolbar by following the procedure described below.

1. Click [View] → [Toolbar] → [Draw].

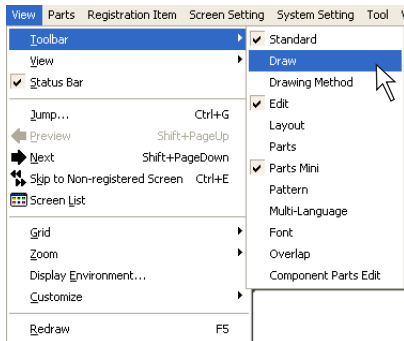

2. The drawing toolbar appears.

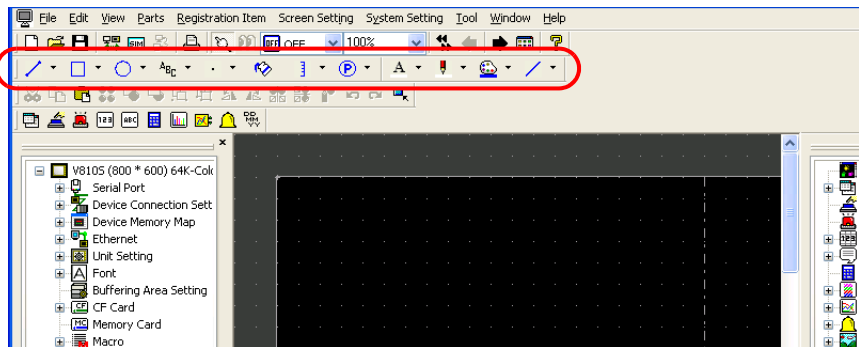

Icons

The drawing toolbar contains the following icons.

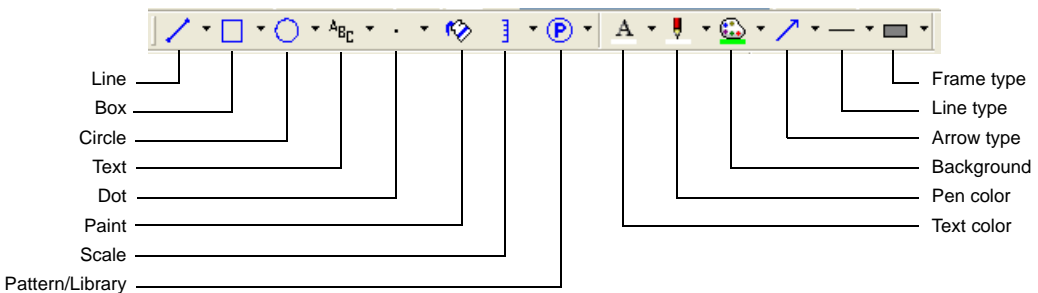

Drawing Method

How to Draw a Line

1. Click the “▼” mark on the right of the [Pen Color] icon on the toolbar.
The color list is displayed. Select the desired color.

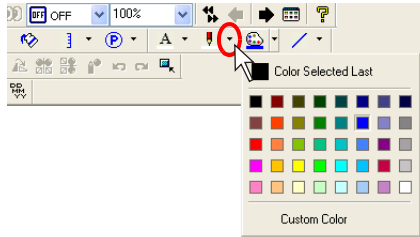

2. Click the “▼” mark on the right of the [Line Type] icon.
The line-type list is displayed. Select the desired line type.

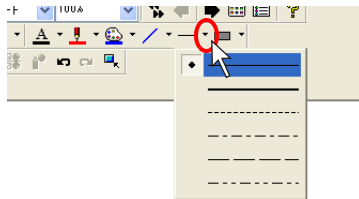

3. Click the [Line] icon on the toolbar.
The [Line] icon is depressed.

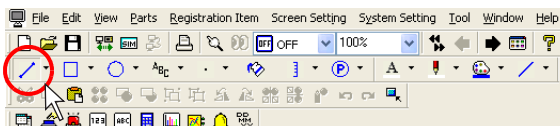

4. Drag the mouse from the start point to the end point.
The line of the type selected in step 2. with the color selected in step 1. is drawn.

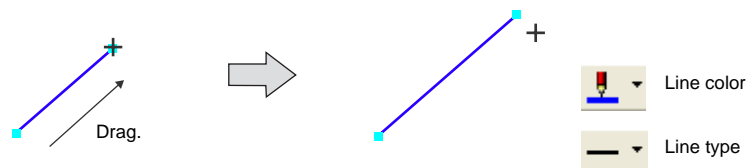

5. To cancel the drawing setting set for the straight line, right-click or click the mouse at the desired position on the screen.
When dragging again without canceling, you can draw the same straight line.

How to Draw a Box

1. Click the “▼” mark on the right of the [Frame Type] icon on the toolbar.
The frame types are displayed. Select the desired frame type. ([With Frame (Paint)] is selected as an example.)

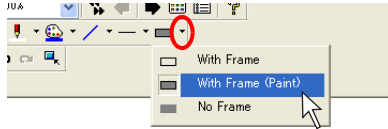

2. Likewise, select the line type and color of the frame from the [Line Type] icon and the [Pen Color] icon respectively.

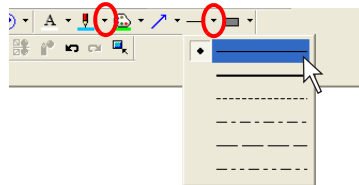

3. Select a paint color for inside the frame from the [Paint] icon.

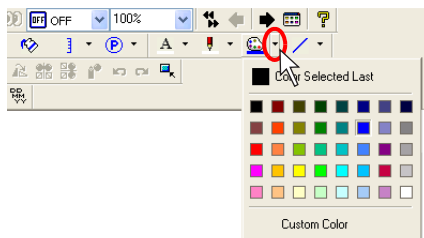

4. Click the [Box] icon on the toolbar.
The [Box] icon is depressed.

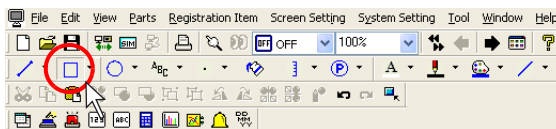

5. Drag the mouse from the start point to the end point.
The box is drawn with the properties selected in steps 1. to 3.

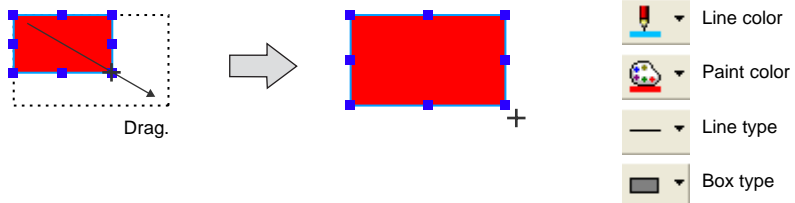

6. To cancel the drawing setting set for the box, right-click or click the mouse at the desired position on the screen.
When dragging again without canceling, you can draw the same box.

How to Enter or Place Text

1. Click the [Text] icon on the toolbar.
The [Text] icon is depressed.

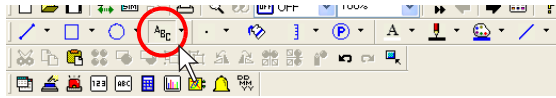

2. Drag the mouse from the start point to the end point.
The field is created and the blinking cursor appears.

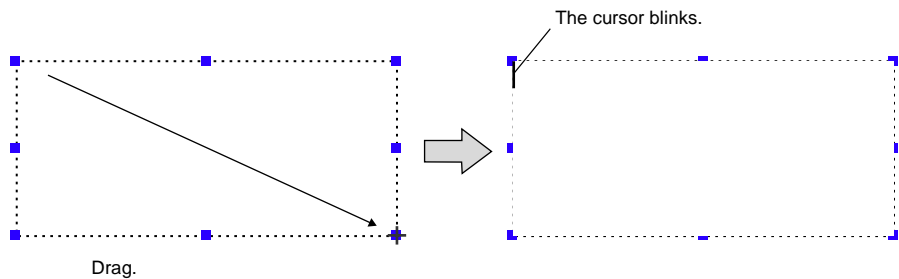

3. Enter the text as required.
(The text is displayed with tentative property at this time. The text property is reflected after performing step 4.)



4. Click the mouse at any position other than the text.
The text entered in step 3. is displayed.

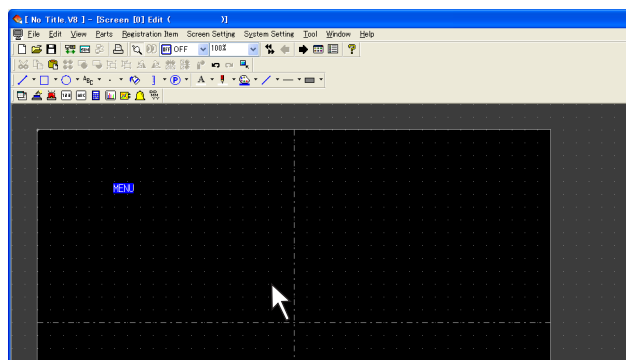

5. Text properties can be changed in the item dialog.
(For the procedure to display the item dialog, see the next section.)

Changing the Graphic Properties

Graphic properties can be changed in each item dialog.

How to Display the Item Dialog

Display by clicking

As default, clicking the item brings up the corresponding item dialog.

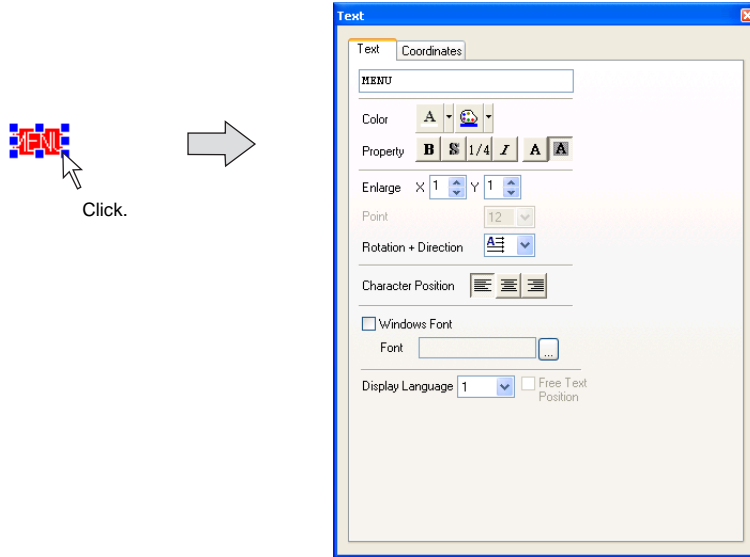

Display by double-clicking

The item dialog can also be displayed by double-clicking.

Click [File] → [Property] and open the [General] tab window. Check [Prohibit Item View Display by Single Click].

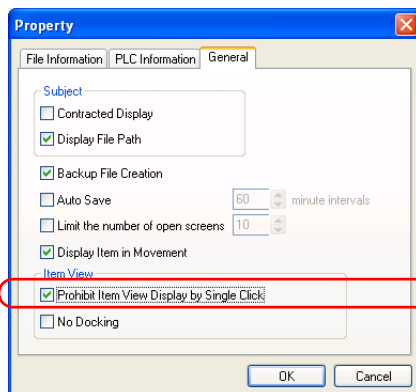

The item dialog is displayed by double-clicking instead of single clicking.

Example of Item Dialog

Line

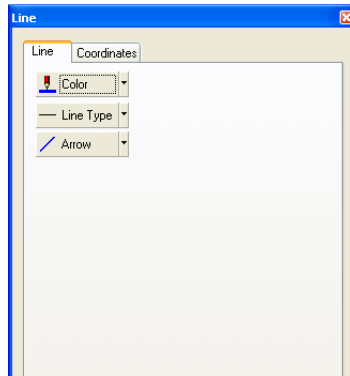

Box

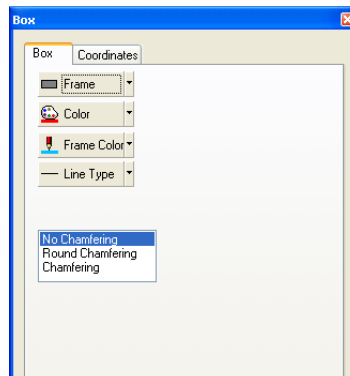

Text

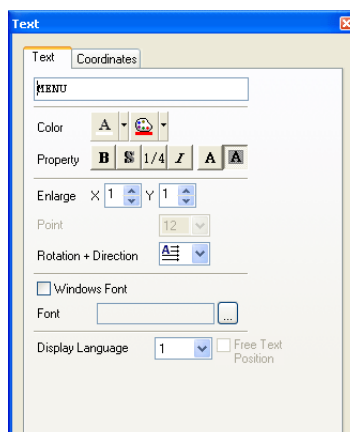

4.5 Parts

This section describes how to place or edit parts.

Placement Procedure

There are four methods to place parts. This section provides each procedure to place the part.

From the Parts List

What is the parts list?

The “parts list” is the window which contains various parts and from which you can select a desired part.

Parts can also be selected from the screen data file (extension: *.V8) in addition to the parts file.

Placement procedure (e.g. switch)

1. Bring up the parts list on the screen.
Select [Parts] → [Parts List].
The [Parts List] window opens.

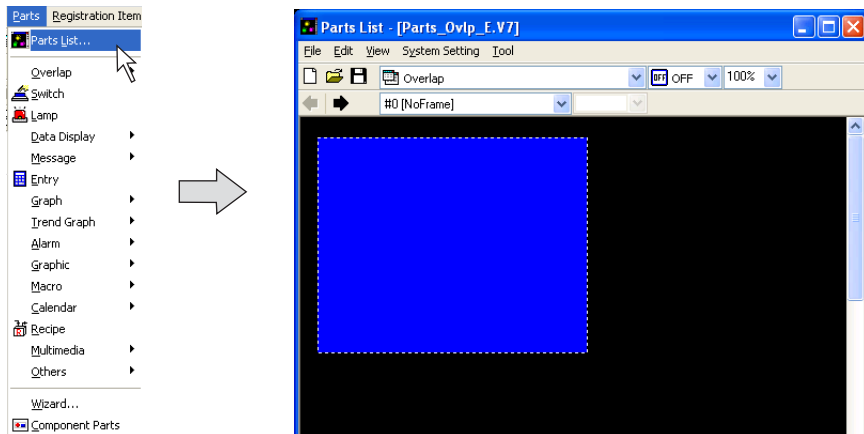

2. Select [Switch] from the pull-down menu. (When it has already been selected, go to step 3.)

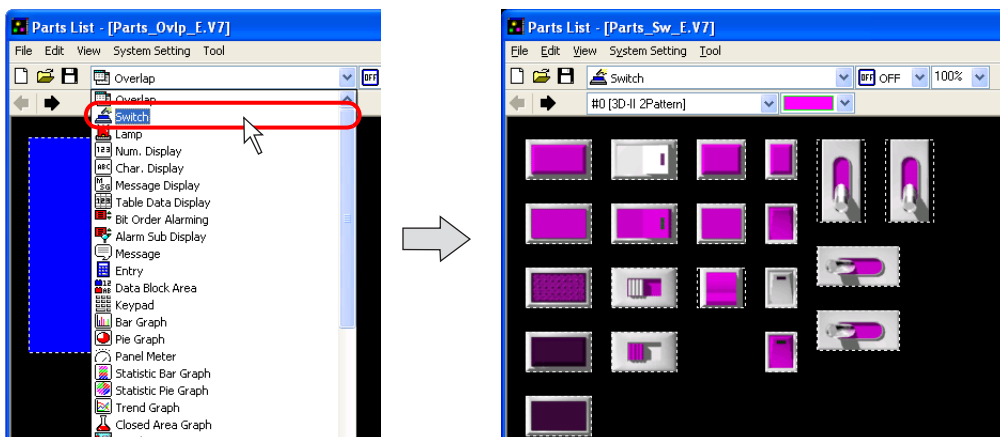

- Find the desired part in the switch list changed with the arrow icon or from the pull-down menu.

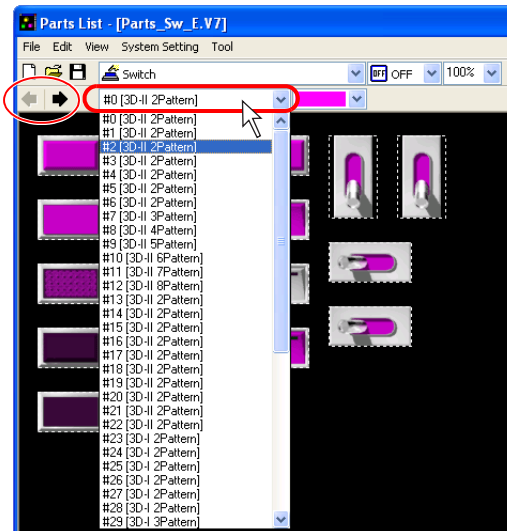

- Select the desired switch and drag it on the screen. A new switch part is placed on the screen.

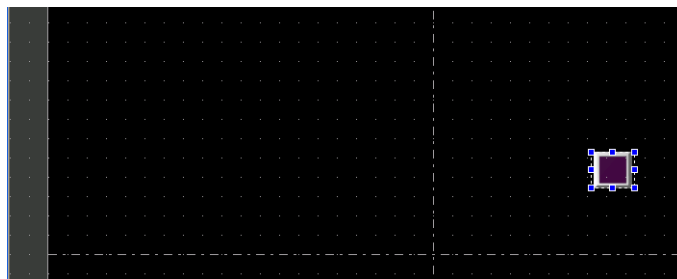
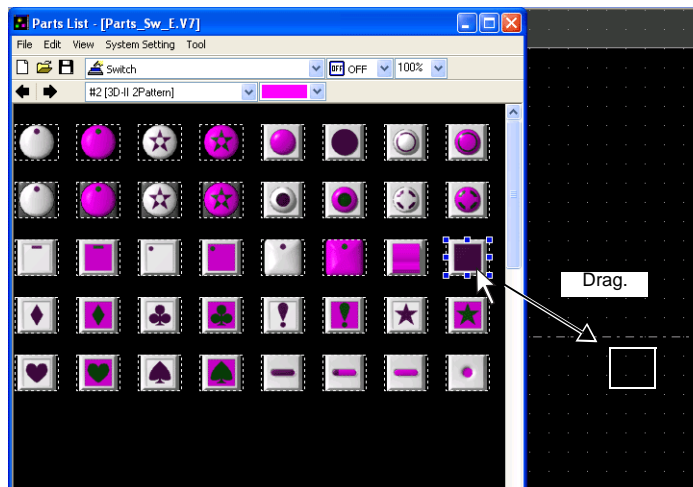



To hide the parts list behind the editing window, uncheck the [Always Display on Top] in the [View] menu of the [Parts List] window.

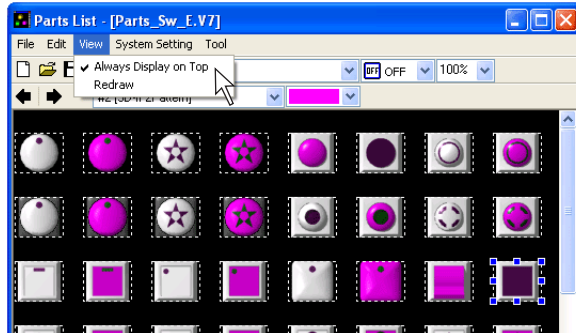

From the [Parts] Menu

Placement procedure (e.g. switch)

1. Click [Parts] → [Switch].

Move the mouse to the editing window. The part is displayed with the cursor.

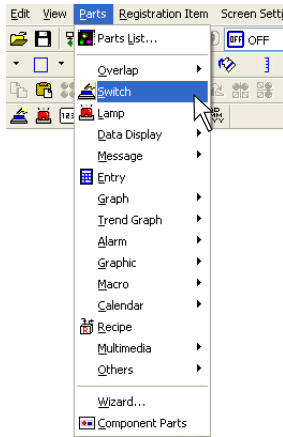

The part is displayed with the cursor moved.



* The part displayed here is the default or the one which was changed or selected last.

2. Click the mouse on the desired position. The switch part selected in step 1. is placed on the screen.

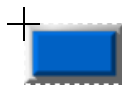

Click.



The switch part is placed.

From the Parts Toolbar

What is the parts toolbar?

This is the menu which contains minimized tools.

There are two types of toolbars: the [Parts] toolbar which contains all of the parts, and the [Parts Mini] toolbar which can be customized with frequently-used parts. This section provides the procedure using the [Parts] toolbar.

Placement procedure (e.g. alarm logging)

1. Bring up the [Parts] toolbar on the screen.
Click [View] → [Toolbar] → [Parts].
(When it has already been checked, go to step 2.)
The [Parts] toolbar is displayed.

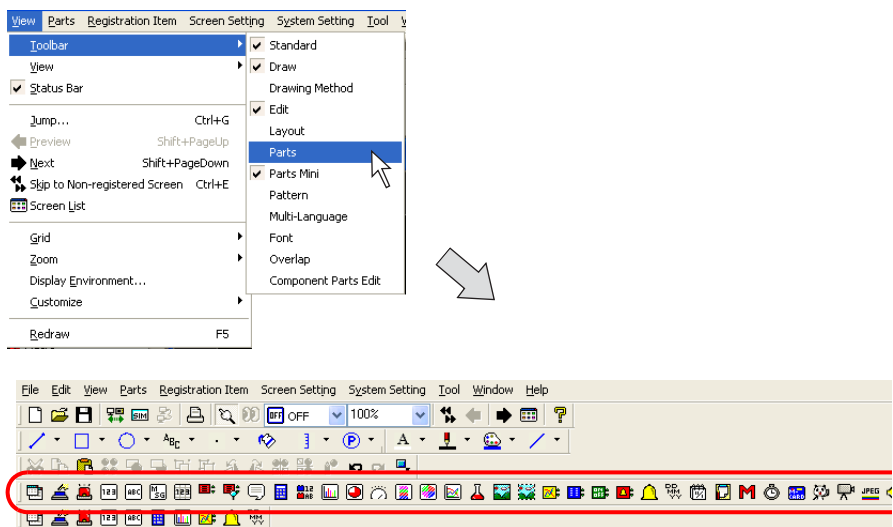

2. Click the [Alarm Logging] icon.
Move the mouse to the editing window. The part is displayed with the cursor.

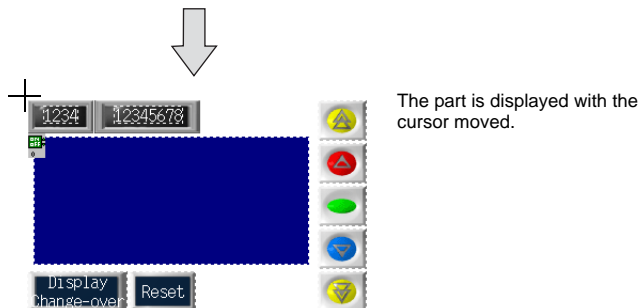
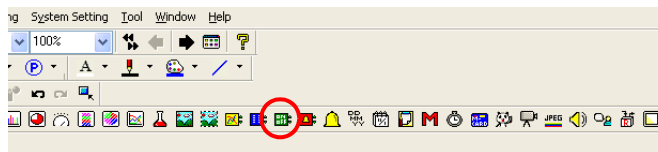

The part is displayed with the cursor moved.

* The part displayed here is the default or the one which was changed or selected last.

- Click the mouse on the desired position. The alarm logging part selected in step 2. is displayed.

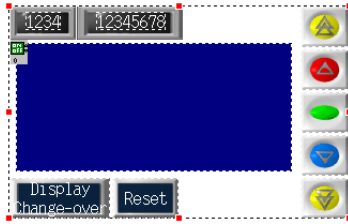

From Catalog View

What is “Catalog View”?

This is the window which displays each part in a tree-structured form.

The window can be displayed as a part of the editor because it is a list-view window style.

Placement procedure (e.g. numerical data display)

- Bring up Catalog View on the screen.
Click [View] → [View] → [Catalog View].
Catalog View is displayed.

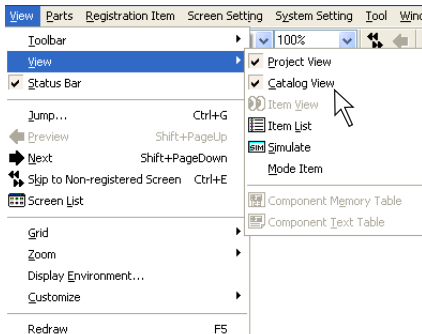

Catalog list-view window (Catalog View)

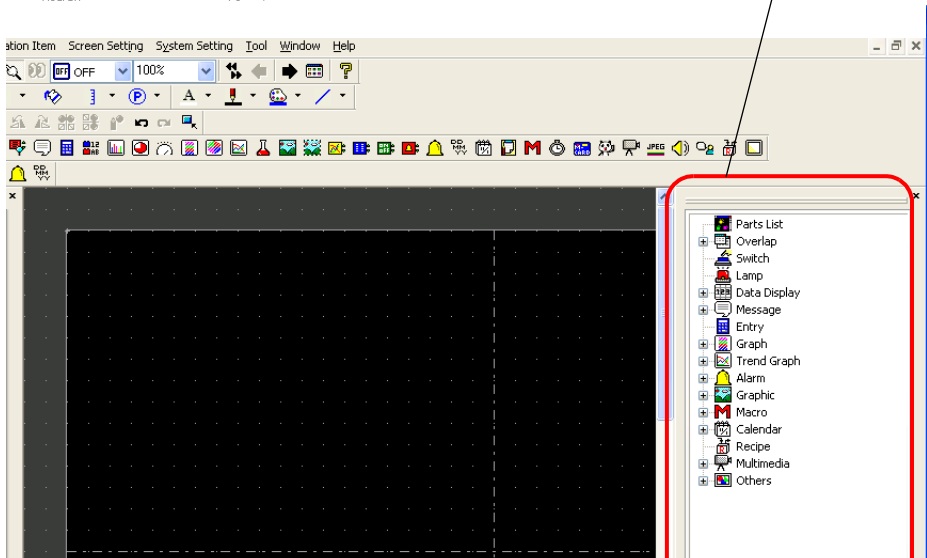

2. Double-click [Data Display] on Catalog View.
The lower hierarchy appears.

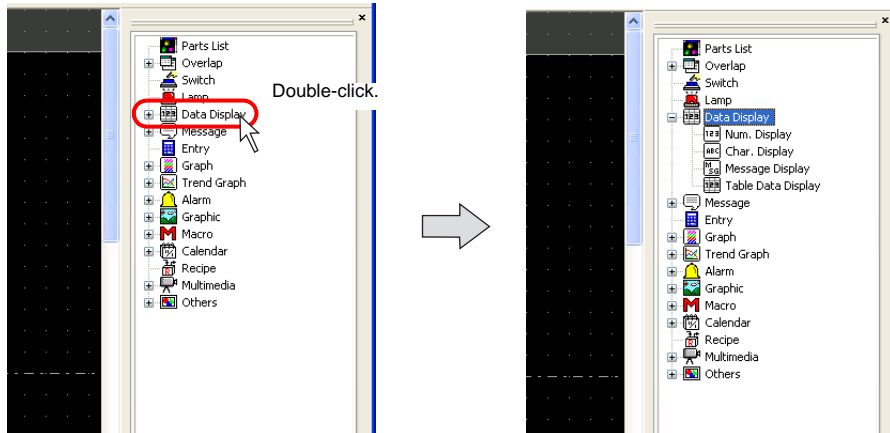

Hierarchical parts are only included in the parts marked with "▣".
When the "▣" mark is not displayed, drag the part directly as described in step 3.

3. Select [Num. Display] and drag it on the screen.
The numerical data display part is placed on the screen.

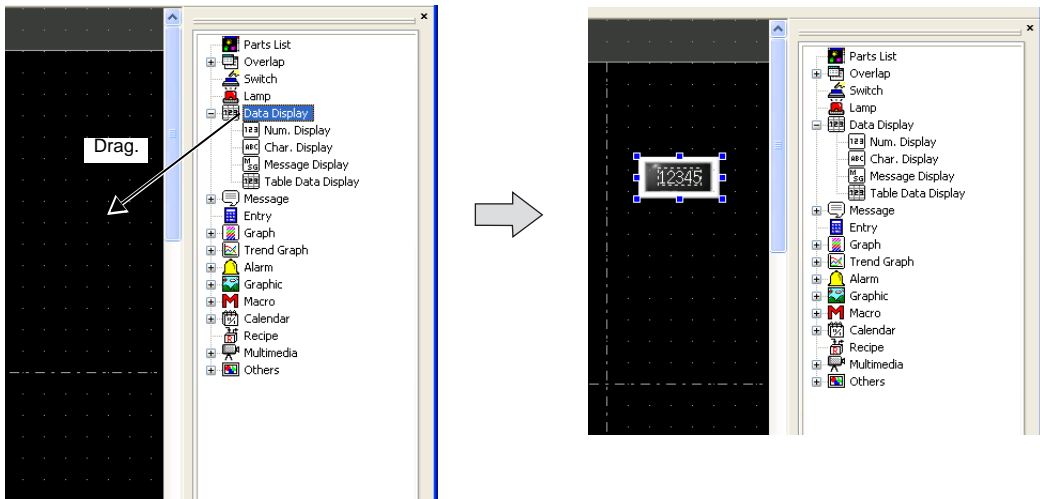

How to Modify the Placed Part (For Single Part)

Item Dialog

The setting for all parts placed on the screen can be changed or checked in the item dialog. Setting options contained in the dialog vary depending on the item; however, the operation procedure is roughly the same.

The item dialog is displayed by clicking or double-clicking the parts placed on the screen.

Changing Part Design

When modifying the design of the placed part, operate the item dialog following the procedure below. (e.g. switch)

1. Click the switch part and bring up the [Switch] item dialog.

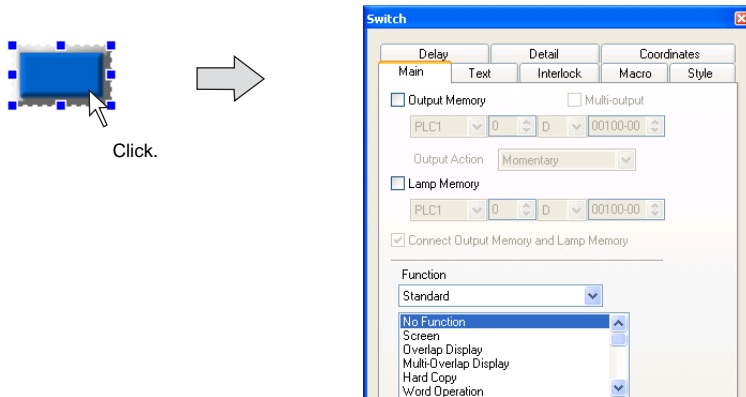

2. Open the [Style] tab window and click the [Change Part] button.

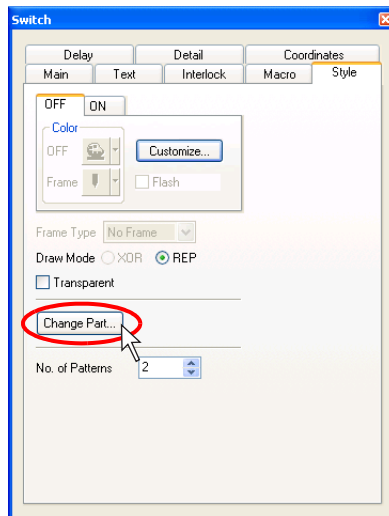

3. The switch parts list is displayed in the [Change Part] dialog.

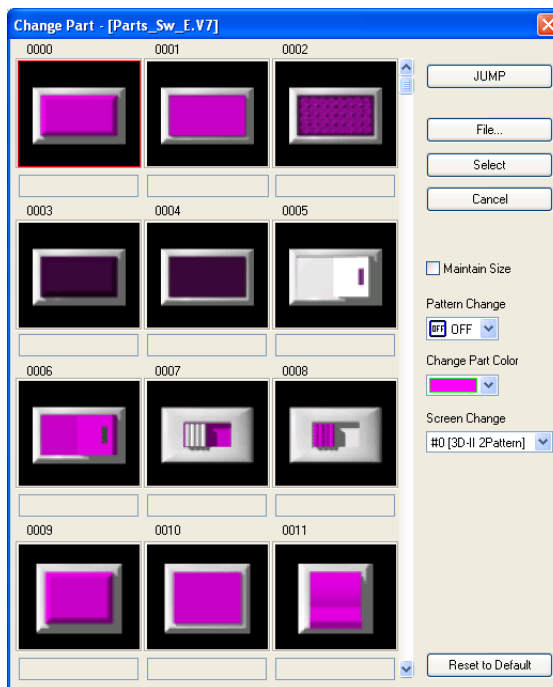

The setting items in the list are described below.

File	Selects the screen data file (*.V8) or parts file (*.V8P). This button is used when a desired part cannot be found in the list or the file including the part to be used is not opened.
Select	Determines the parts selected from the list. Clicking this button replaces the existing part with the new one, and closes the [Change Part] dialog.
Cancel	Closes the [Change Part] dialog.
<input type="checkbox"/> Maintain Size	When this box is checked, the design of the placed part can be changed while its size and other settings are maintained. When this box is unchecked, the default size of the part is reflected when its design is changed.
Pattern Change	This option is valid only for the switch or lamp part. The display pattern for the OFF, ON or P3 status can be checked on the parts list.
Change Part Color	This option is valid only for the 3D part. The color of the parts displayed in the list is changed.
Screen Change	The parts list display is changed to another.
Reset to Default	Displays the default parts list to be selected at the first start-up of the editor.

4. Choose the desired part and click the [Select] button.
The [Switch] dialog is displayed again. The selected part is displayed on the screen.

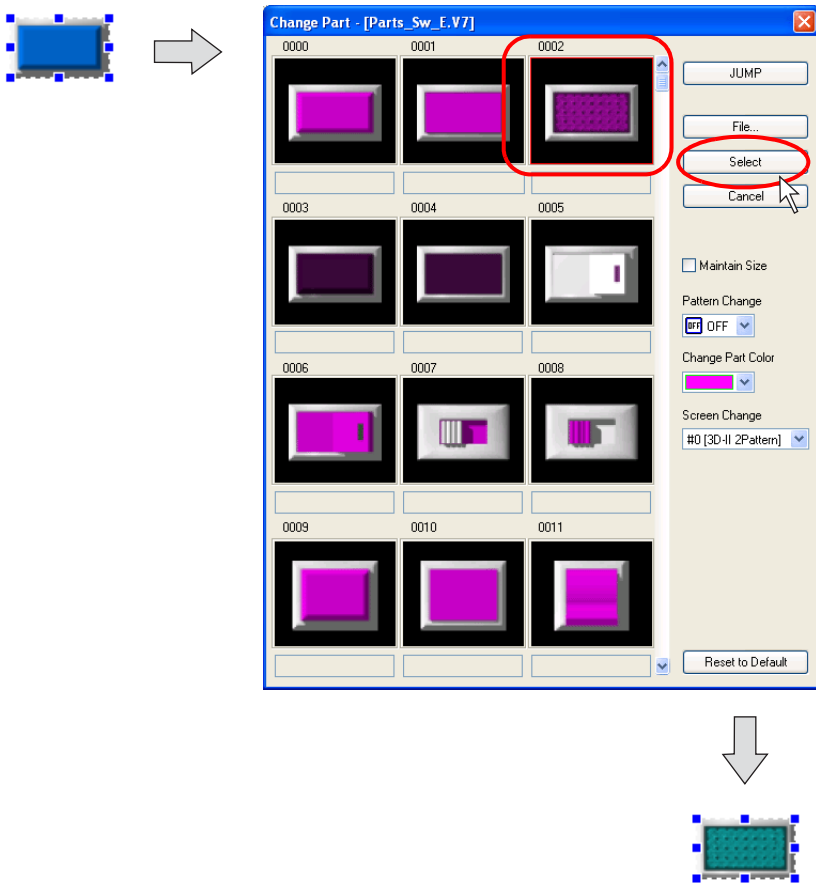

Changing Coordinate and Size

In order to change the part location, it can be designated in the item dialog.

For the item whose size can be changed by dot size designation, such as a switch, lamp, graph, box or circle, it is possible to change the part size in the item dialog as well.

Following example shows the case of the box.

1. Click the box part and bring up the [Box] item dialog.

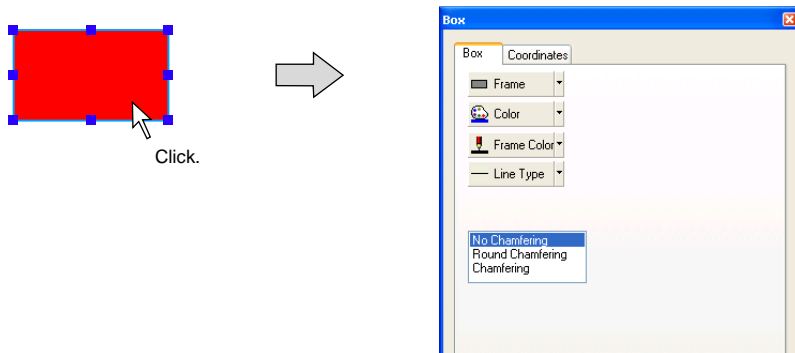

2. Open the [Coordinates] tab window.

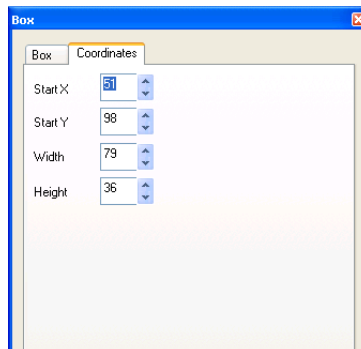

Start X (dots)	Specify the X coordinate of upper left of the box.
Start Y (dots)	Specify the Y coordinate of upper left of the box.
Width (dots)	Specify the width of the box.
Height (dots)	Specify the height of the box.

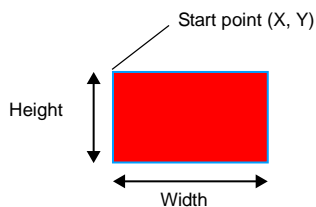

3. When the desired value is specified, the box on the screen is moved or transformed.

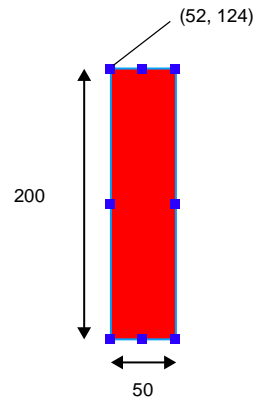
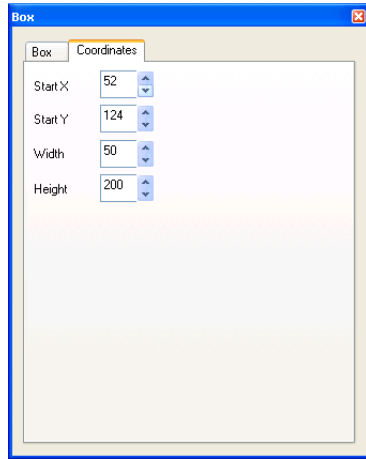

Transformed according to the value set for [Width] and [Height].

How to Modify the Placed Part (For Linked Part)

What Is Linked Part?

Unlike single parts, such as a switch, lamp, data display, etc, there is a kind of part that consists of multiple individual parts, but is placed as a single part (e.g. bit order alarming, alarm tracking, trend sampling, etc.). This is called a "linked part".



When the part is selected with the red handle by clicking, it is a linked part.

To change the size or delete unnecessary items included in the linked part, it is necessary to remove the linkage to make it possible to perform layout or edit individually. This section describes the procedure.

Removing linkage

1. Click the linked part.

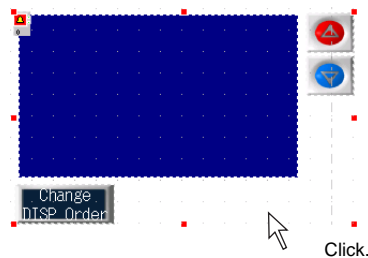

2. Click [Edit] → [Link] → [Link Cancel], or right-click the mouse and click [Link] → [Link Cancel]. The selected linked-part is separated into individual pieces.

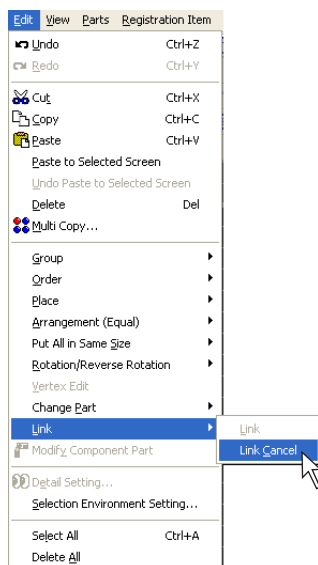

OR

Right-click.

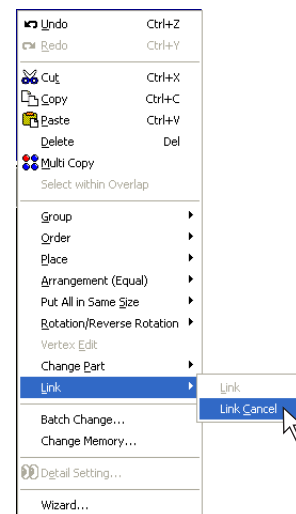

Linkage

We recommend to link separated parts again when the editing is completed. Follow the procedure below to link the parts.

1. Select the parts to be linked together.

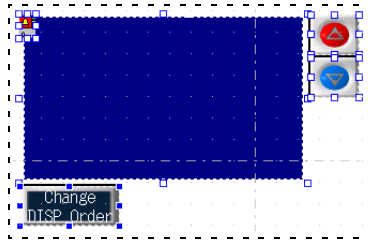

Drag the mouse enclosing all of the parts to be linked.



If it is difficult to select parts at one time, click the parts one by one while holding down the [SHIFT] key. Multiple parts can be selected.

2. Click [Edit] → [Link] → [Link], or right-click the mouse and click [Link] → [Link]. The selected parts are linked and the red handle is displayed around the linked part.

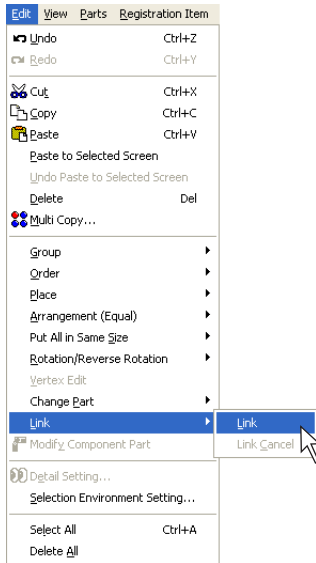

OR

Right-click.

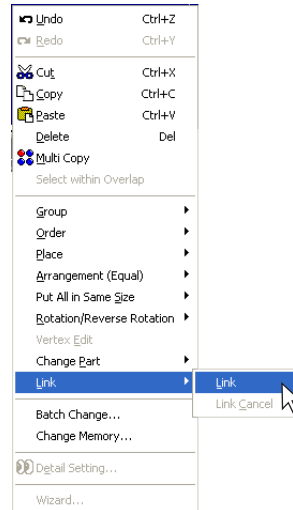

Example of Modification (For Alarm Tracking)

This section provides the procedure to change the linked part as shown below.

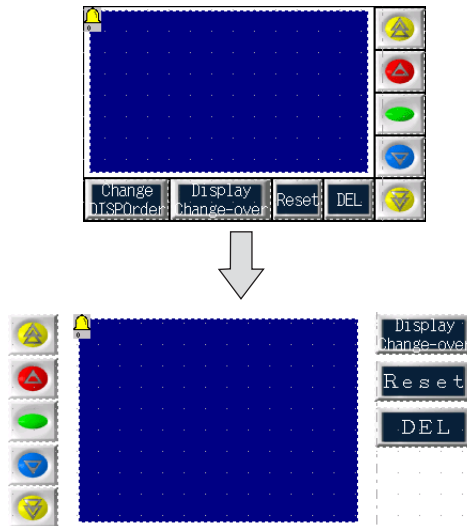

1. Select the alarm tracking part placed on the screen. The parts is enclosed with the red handle.



2. Right-click the mouse and click [Link] → [Link Cancel] while the parts is selected as in step 1. Linkage is removed.

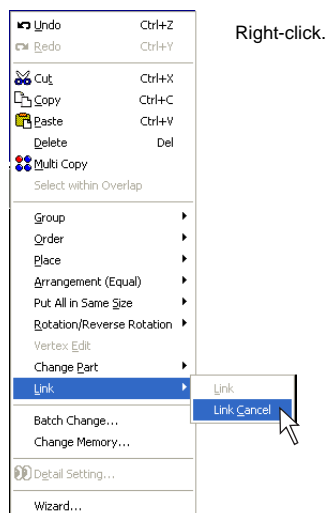

3. Change the parts layout as shown in the figure below.

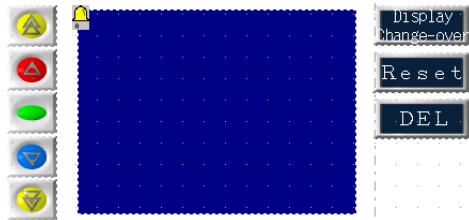

* The [Alarm Tracking] icon can also be moved individually; however, we recommend to place it at the upper left of the display area part.

4. When the layout is determined, select all parts to be linked, and right-click the mouse and click [Link] → [Link].
The selected parts become a linked part.

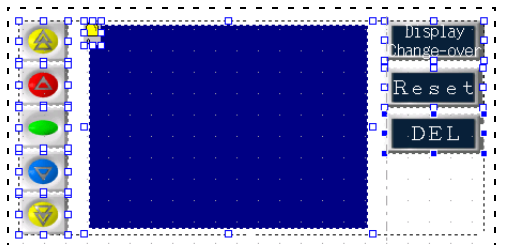

Drag the mouse enclosing all of the parts to be linked.



Right-click.

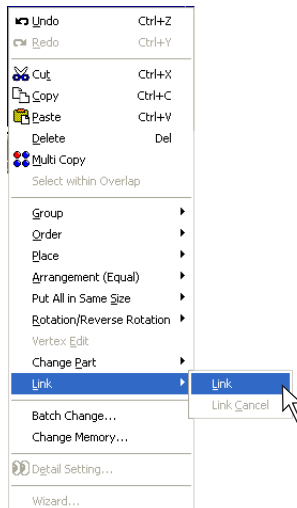

4.6 Library

What Is the Library?

The "library" is the area that stores items or parts used for various functions instead of the screen. It is called to the screen or the overlap display as needed.

There are three types of libraries; "message" used for registering messages, "graphic library" used for registering graphics and "overlap library" used for registering overlap displays.

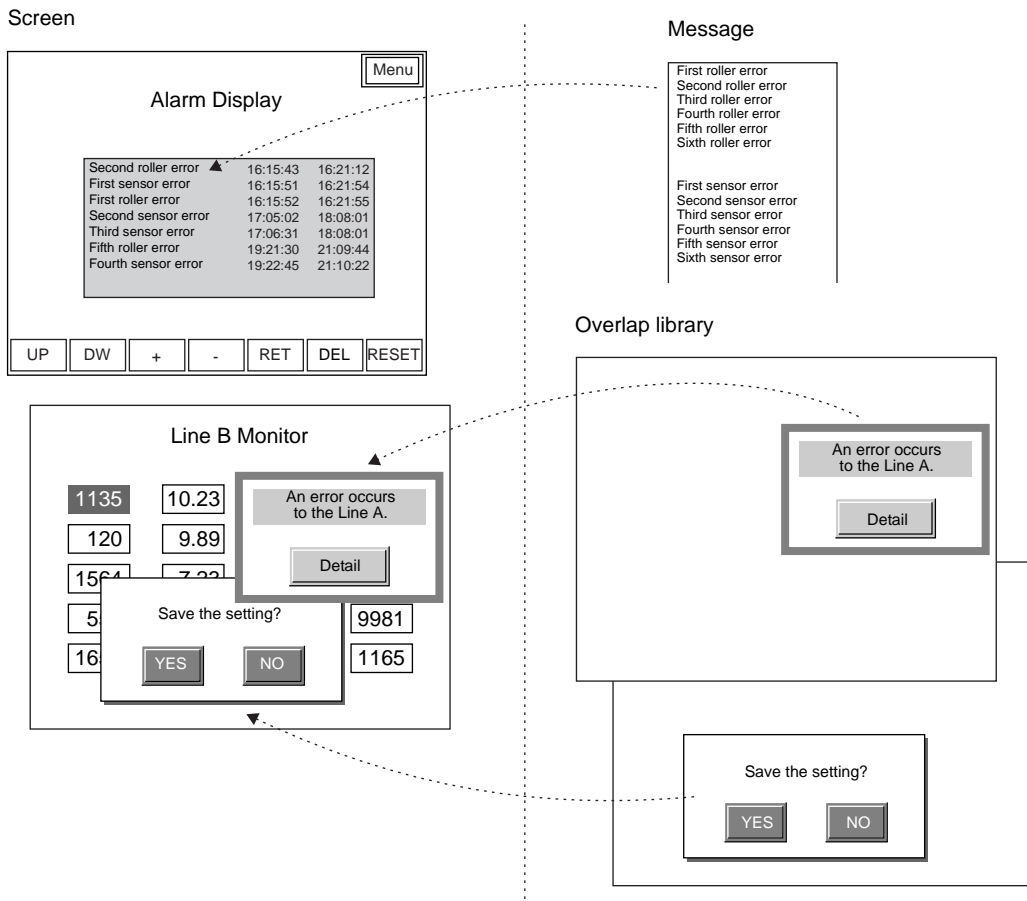

The library can be in the menu selected from the [Registration Item] menu or Project View (project list-view window).

How to Edit the Library

The editing procedure varies depending on the library type.

This section describes the procedure for the two frequently-used functions; [Message] and [Overlap Library].

Message

1. Click [Registration Item] → [Message].

The [Message] dialog is displayed. Specify the desired group number and click [OK].

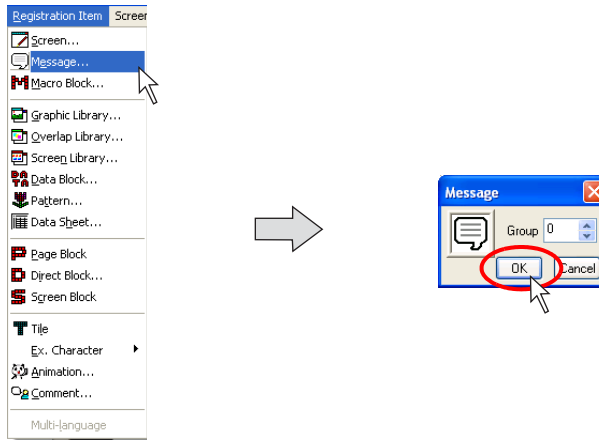

2. The [Message] window opens.
Register messages to be displayed.

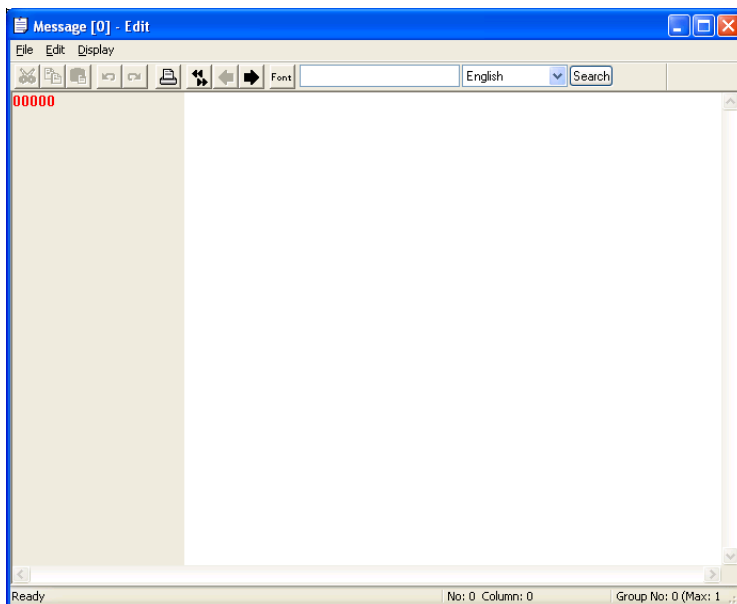

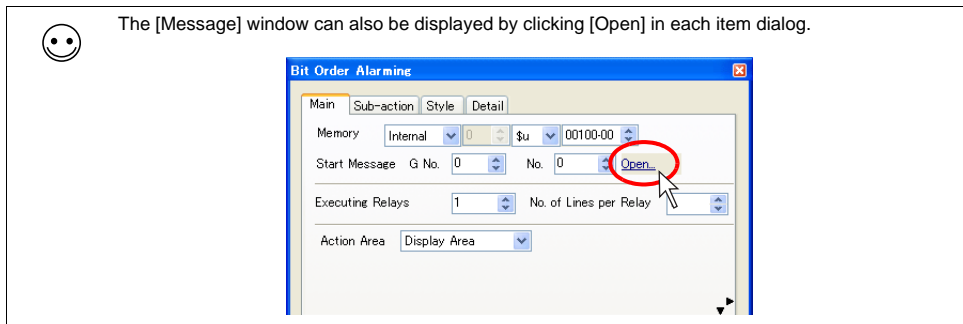

- When the editing is completed, click [File] → [Close] or click the [Close] button.

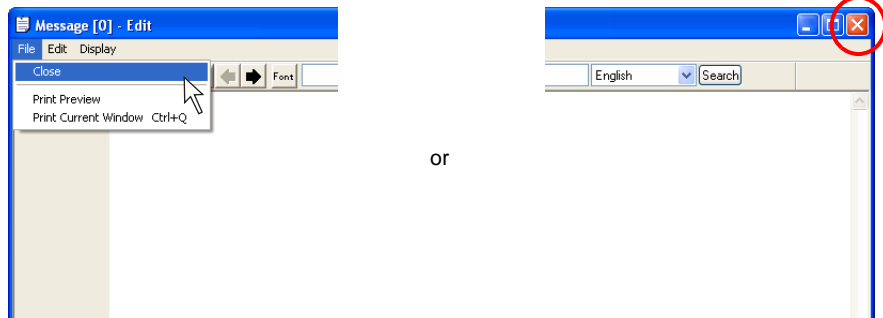

- The screen editing window is displayed again.

Overlap Library

- Click [Registration Item] → [Overlap Library].
The [Overlap Library] dialog is displayed.
Specify the desired overlap-library number and click [OK].

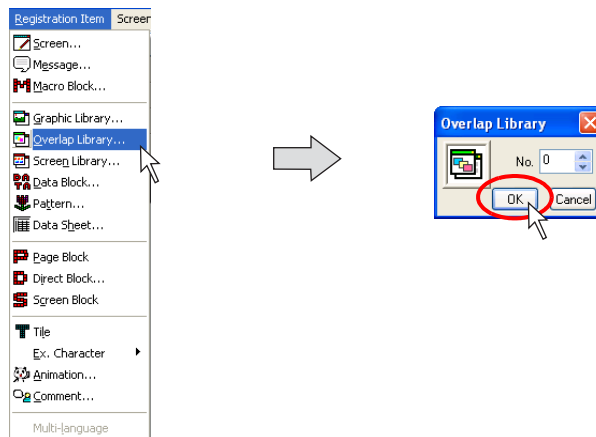

2. The [Overlap Library] window opens.
Register and edit the overlap display.

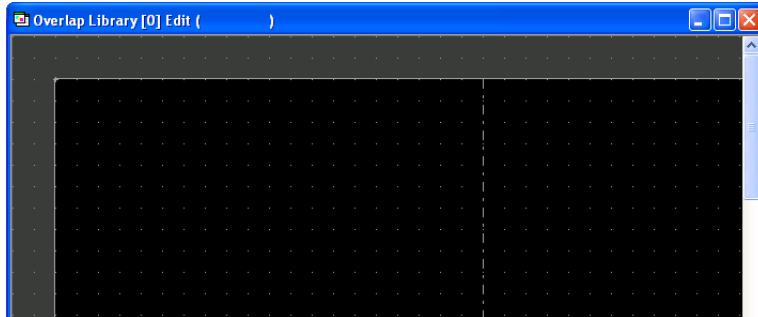

To open the [Overlap Library] window for the call-overlap display, click [Refer] in the [Call-overlap] item dialog or double-click the [Call-overlap] icon.

Double-click the icon.



or

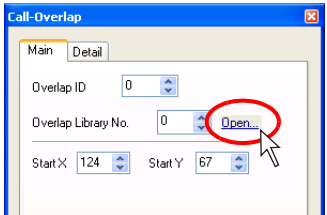

Click.

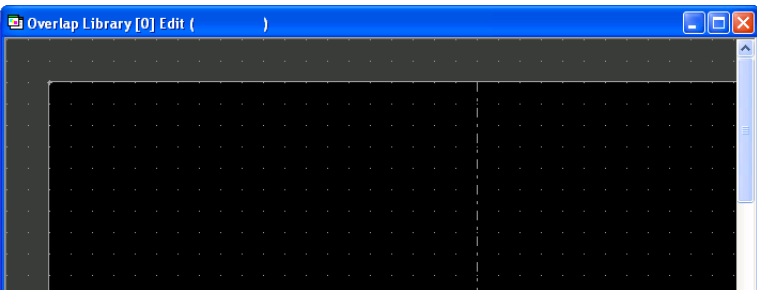

The diagram illustrates two ways to open the "Overlap Library" window. On the left, a mouse cursor is shown double-clicking a "Call-Over" icon. On the right, a "Call-Over" dialog box is shown with the "Open..." button circled in red and a mouse cursor clicking it. A large gray arrow points from these actions down to a screenshot of the "Overlap Library [0] Edit" window, which is identical to the one shown in the previous step.

3. When editing has been completed, click [File] → [Close] or click the [Close] button.

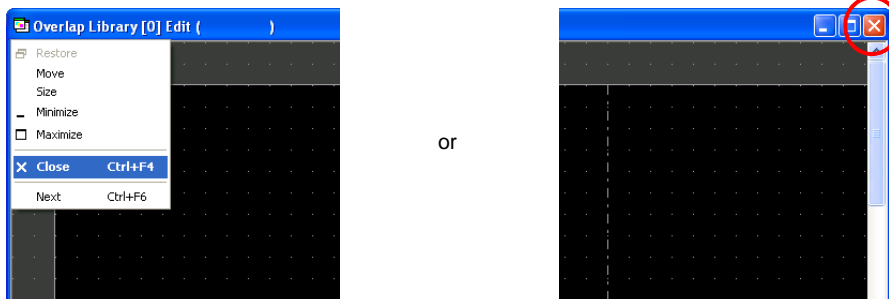

4. The screen editing window is displayed again.

4.7 Examples of Screen Editing

Trend Sampling

Example Screen

We will create a trend sampling screen like the one shown below.

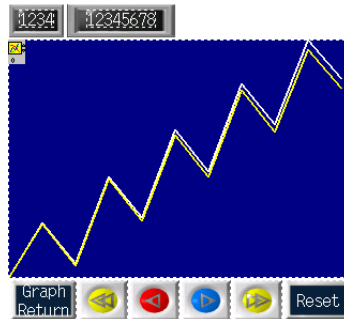

Setting Procedure

Layout of trend sampling part

1. Select [Parts] → [Trend Graph] → [Trend Sampling], or click the [Trend Sampling] icon in the [Parts] toolbar.

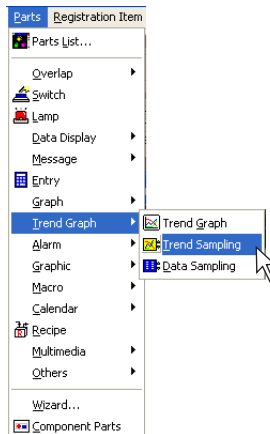

OR

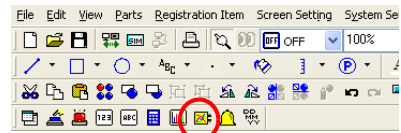

2. The trend sampling part moves together with the mouse cursor.
Click to place the part on the screen.

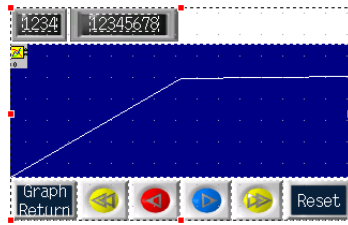

Setting the trend sampling part

1. Next, we set trend sampling for the placed part.
Click the [Trend Sampling] icon.
The [Trend Sampling] item dialog is displayed.

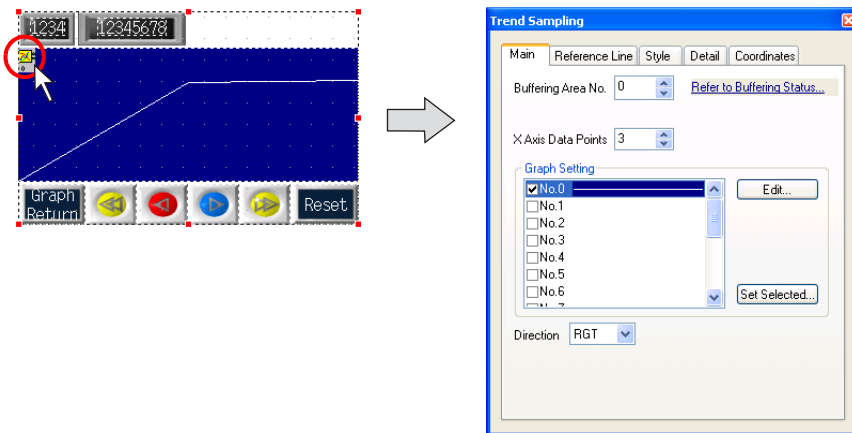

* If the item dialog is not displayed, double-click the trend sampling part.

2. Set as shown below.

Setting Option	Set Value
Buffering Area No.	0
Refer to Buffering Status	See page 4-53.
X Axis Data Points	11
Graph Setting	See below.
Direction	→

- Graph Setting
 Check the No. 0 check box and click the [Edit] button.
 The [Graph No. 0] dialog is displayed. Make settings as shown below.

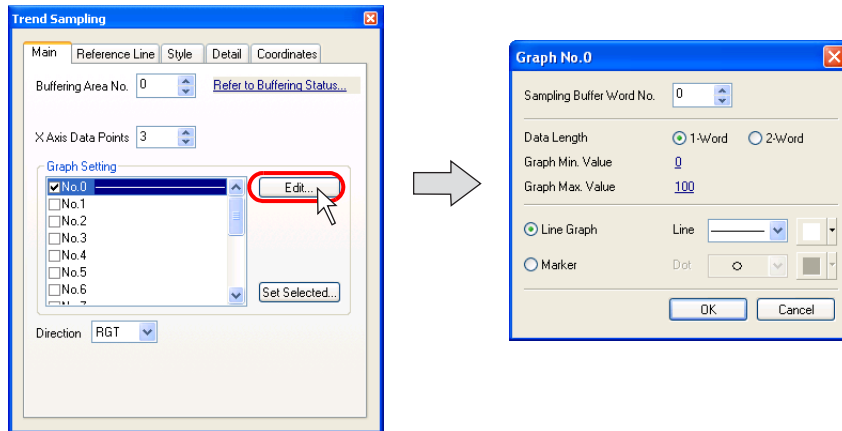

Setting Option	Set Value
Sampling Buffer Word No.	0
Data Length	1
Graph Min. Value	0
Graph Max. Value	9999
Line Graph	(Select)
Line	Thick
Line color	White

When settings are completed, click [OK].
 The [Trend Sampling] item dialog is displayed again.

This also allows us to start setting for the second line graph. Check the No. 1 check box and click the [Edit] button. The [Graph No. 1] dialog is displayed. Make settings as shown below.

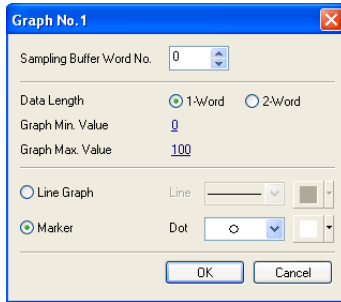

Setting Option	Set Value
Sampling Buffer Word No.	1
Data Length	1
Graph Min. Value	0
Graph Max. Value	9999
Line Graph	(Select)
Line	Thick
Line color	Yellow

When settings are completed, click [OK]. The [Trend Sampling] item dialog is displayed again.

- Having clicked on the placed trend sampling part, right-click the mouse to display the right-click menu.

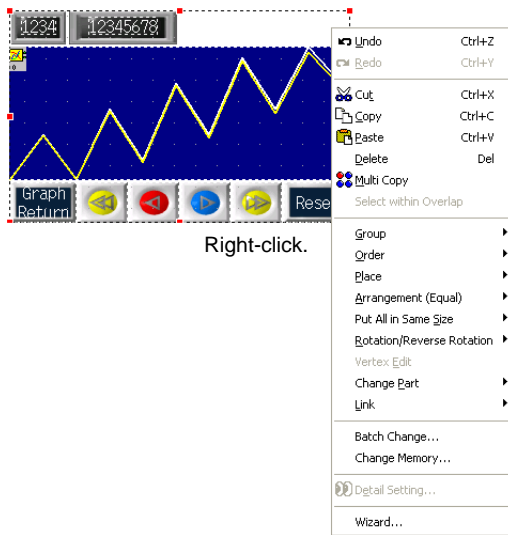

Right-click.

4. Click [Link] → [Link Cancel].
This setting allows you to move the trend sampling area and the switches independently.

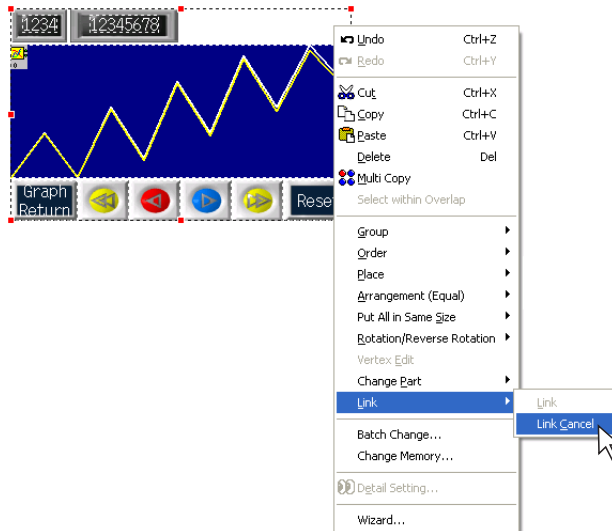

5. The layout changes to the one shown below.

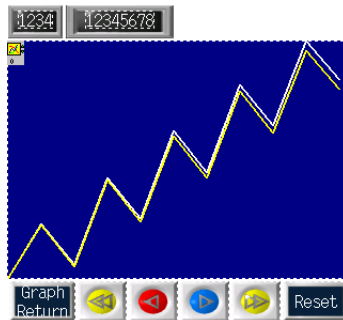

- Again, select each part by clicking it, then right-click the mouse to display the right-click menu.

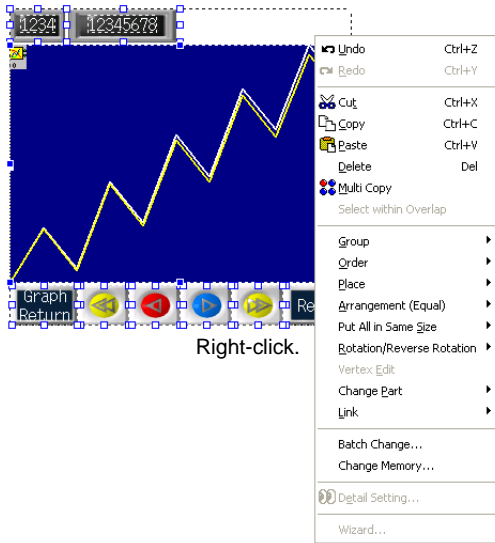

- Click [Link] → [Link].
This setting links parts that have been independent.

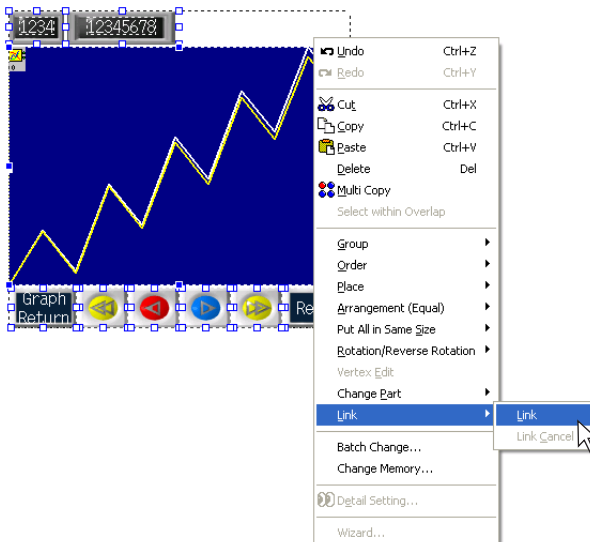

Setting the buffering area

1. With the [Trend Sampling] item dialog displayed, click [Reference Buffering Status]. The [Buffering Area Setting] dialog is displayed.

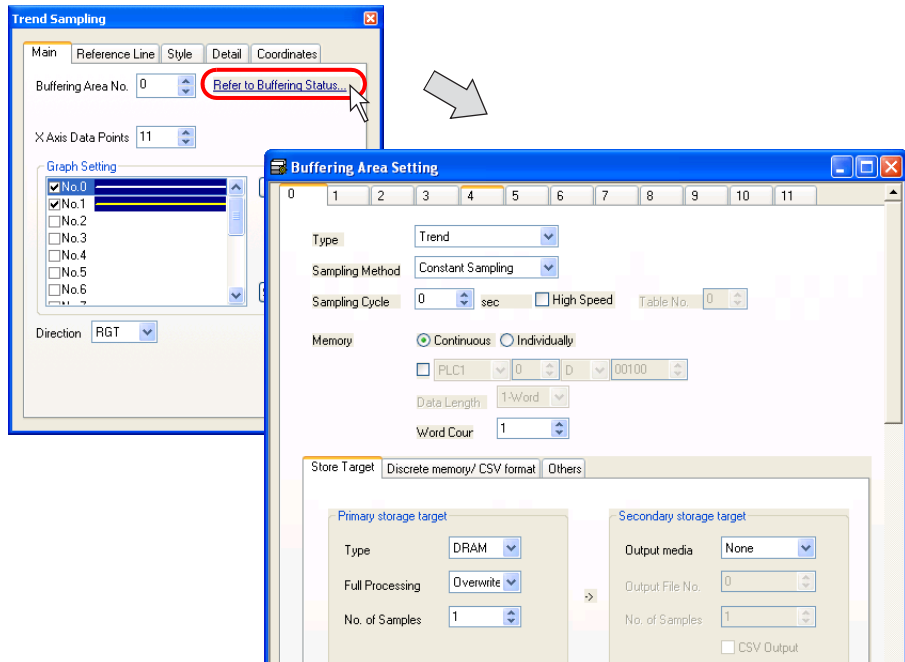

2. Make settings as shown below.

Setting Option		Set Value	
Type		Trend	
Sampling Method		Constant Sampling	
Sampling Cycle		1	
Memory		Continuous	
Checked (top memory)		D100	
Data Length		1-Word	
Word Count		2	
Store Target	Primary storage target	Type	SRAM
		Full Processing	Overwrite
		No. of Samples	1000
	Secondary storage target	Output media	CF Card
		No. of Samples	1000
Discrete memory/CSV format		CSV format	As required
Others			No setting

On completion of setting, close the [Buffering Area Setting] dialog.



The [Trend Sampling] dialog is cleared from the screen at the moment the [Buffering Area Setting] dialog is displayed.
If you want to check the settings in the [Trend Sampling] dialog again, click the [Trend Sampling] icon.

The setting has been completed.

Sampling Operation

Storing data

Depending on the buffering area setting, the line data is stored in the primary storage and the secondary storage.

If "SRAM" is set for "Primary storage target" and [CF Card] is set for "Secondary storage target", the data is stored in the manner indicated below.

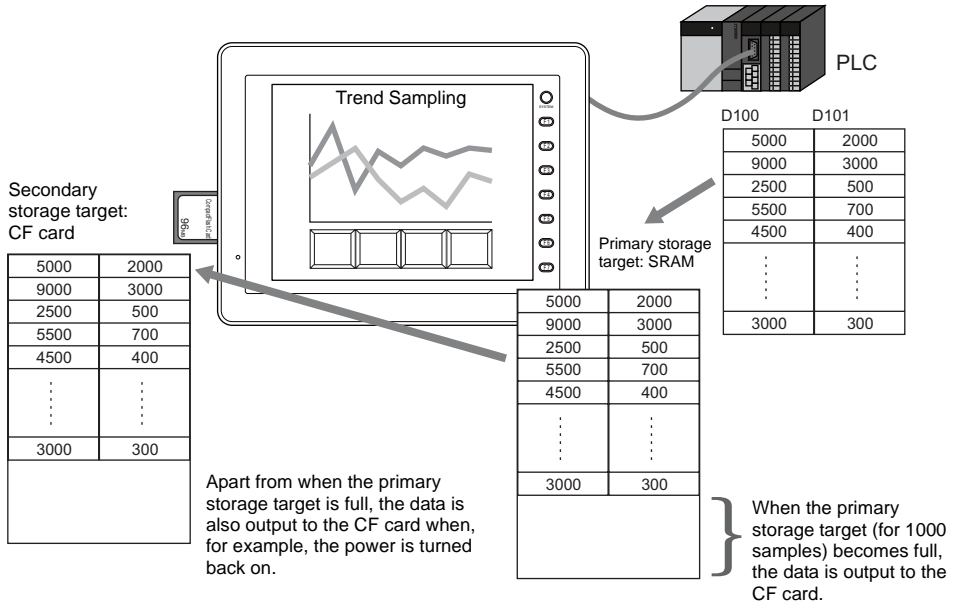

SRAM format

Since [SRAM] is set for “Primary storage target”, after data transfer (for details on the transfer method, see “5 Transfer”), [Error: 161 Data has some error.] is displayed on MONITOUCH.

- If this error occurs, press the [Main Menu] switch on MONITOUCH and then press the [SRAM/Clock] switch to display the [SRAM/Clock] window: format the SRAM in this window to clear the error.
- It is also possible to make settings so that when a SRAM is used it is automatically formatted, which means that [Error: 161 Data has some error.] doesn't occur.
Click [System Setting] → [Unit Setting] → [SRAM/Clock].
The [SRAM/Clock Setting] dialog is displayed.
When the [SRAM Auto Format] check box is checked, no error occurs immediately after transfer.

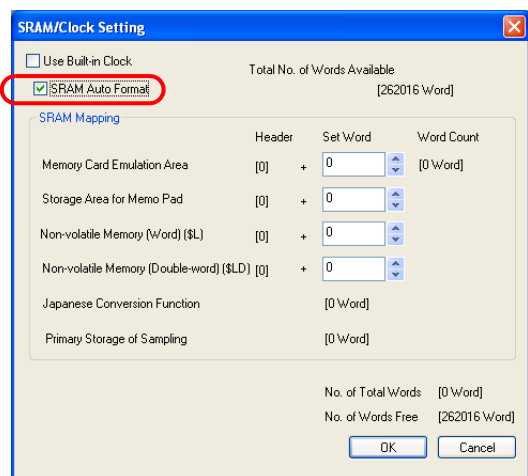
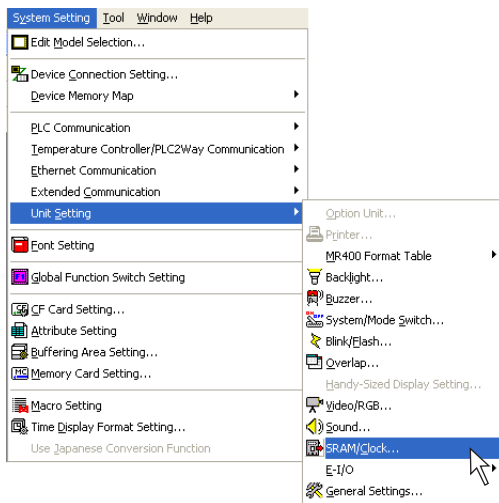



For more information, see “Appendix 2 SRAM/Clock Setting” in the V8 Series Reference Manual.

Overlap Display

Example Screen

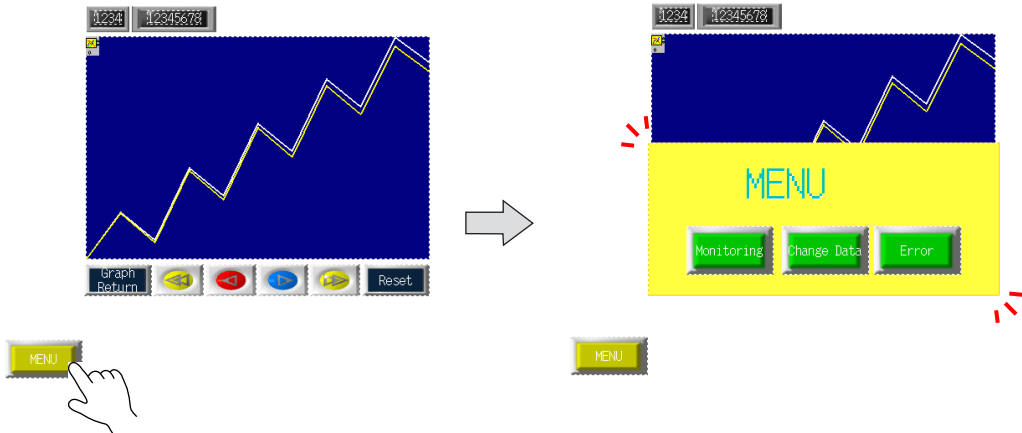
Here we will create a screen that has an overlap display over the current display and provides menu selections, which is displayed when a menu switch is pressed as shown below.



 **What Is “Overlap” Display?**

The “overlap” display part is an element that you can use for creating a screen display. “Normal overlap” is a sectional window registered for each screen. “Multi-overlap” or “call-overlap” is also a sectional window that is called up from the registered “overlap libraries” on the screen with multi- or call-overlap setting.

Setting Procedure

Placing the call-up switch

1. Click [Parts] → [Switch] or click the [Switch] icon on the [Parts] toolbar.

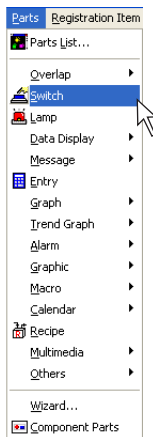

OR

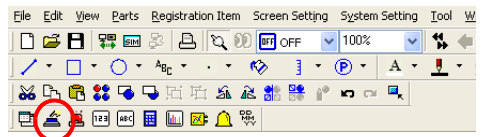

- The switch part moves together with the mouse cursor.
Click to place the part on the screen.



- Click the placed switch.
The [Switch] item dialog is displayed.

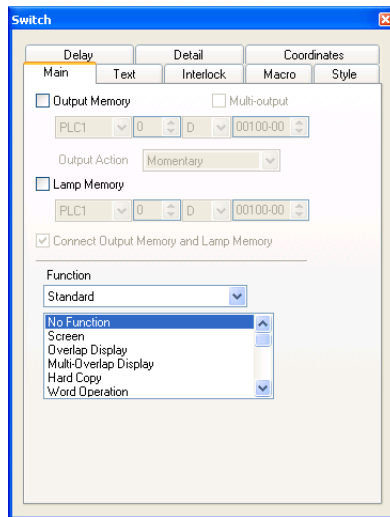

- If you want to change the design, display the [Style] tab window.
Click the [Change Part] button to call up the [Change Part] dialog for switches.
Select the design you want, then click the [Select] button.
The [Switch] item dialog is displayed again.

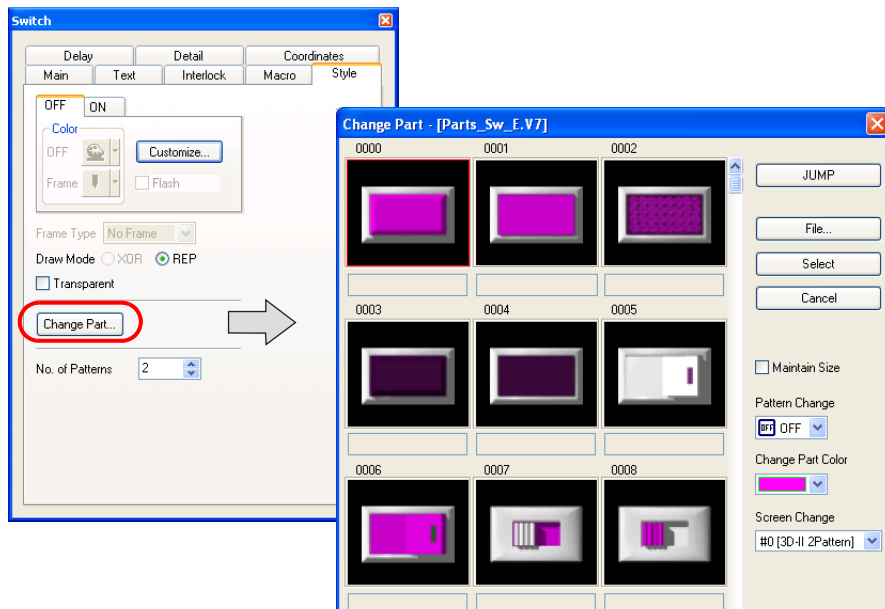

5. In the [Main] tab window, set [Overlap Display] for [Function]. Set [0] for [Overlap ID] and [ALT] for [Action].

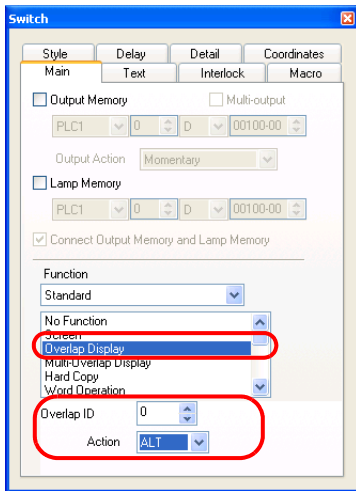

6. In the [Text] tab window, enter "MENU" as the text when the switch is "OFF".

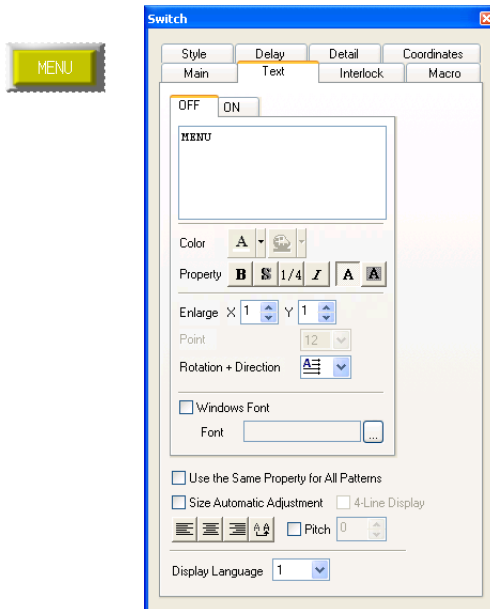

Switch setting has now been completed.

Placing a normal overlap display part

1. Select [Parts] → [Overlap] → [Normal Overlap], or click the [Overlap] icon on the toolbar.

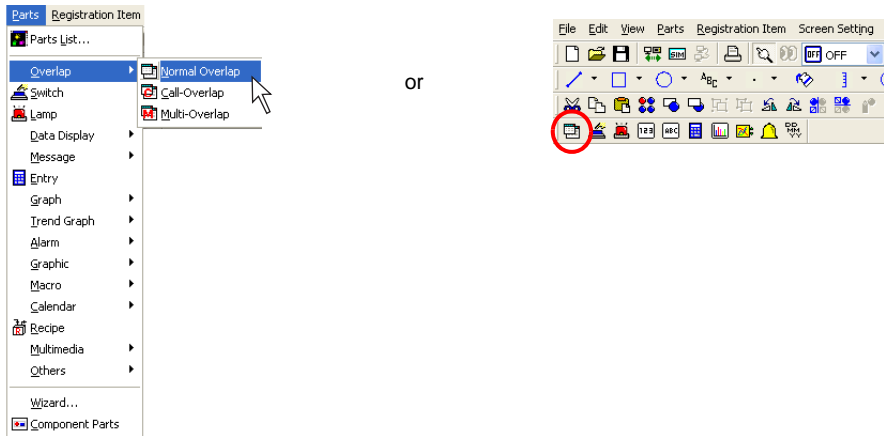

2. The overlap part moves together with the mouse cursor. Click to place the part on the screen.



The part is displayed with the cursor moved.

3. Click the mouse on the desired position. Normal overlap display is placed. The [Normal Overlap] item dialog is displayed at the same time.

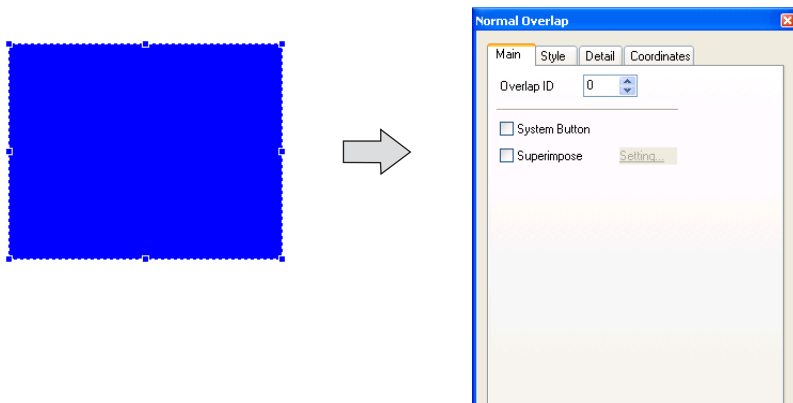

* If the item dialog is not displayed, double-click the normal overlap display part.

4. To change the part design, open the [Style] tab window in the item dialog, and click [Change Part].

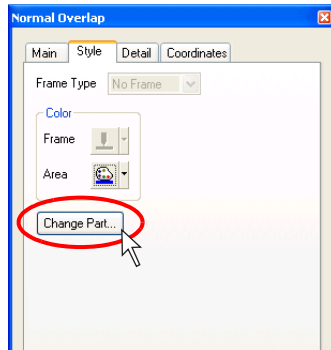

5. The [Change Part] dialog is displayed. From the pull-down menu of [Screen Change], find the desired design. Click it on the list and then click the [Select] button. The [Style] tab window is displayed again. You can change colors as well in the [Style] tab window.

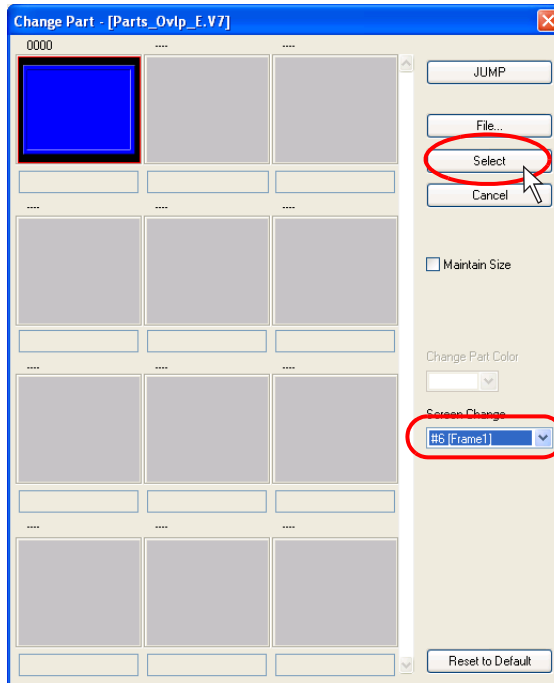

6. If another setting, such as display size, is necessary to be changed, change the setting from the item dialog.

Item placement on overlap display

The procedure for creating an overlap display with items placed on it as shown below is explained here.

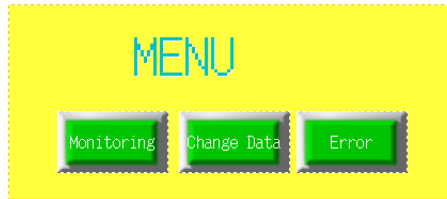

1. Right-click the mouse on a screen on which a normal overlap display has been placed.
 - * Make sure the normal overlap display is not selected when you right-click.

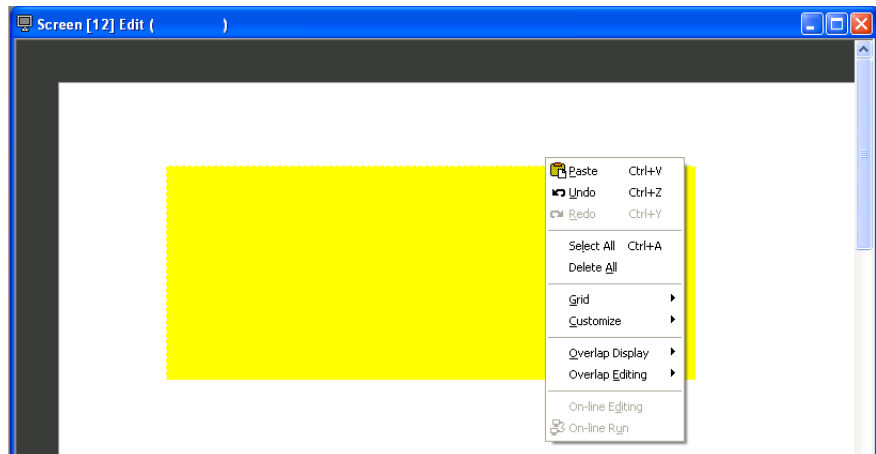

2. Click [Overlap Editing] → [No. 0] to make the icon next [No. 0] depressed.

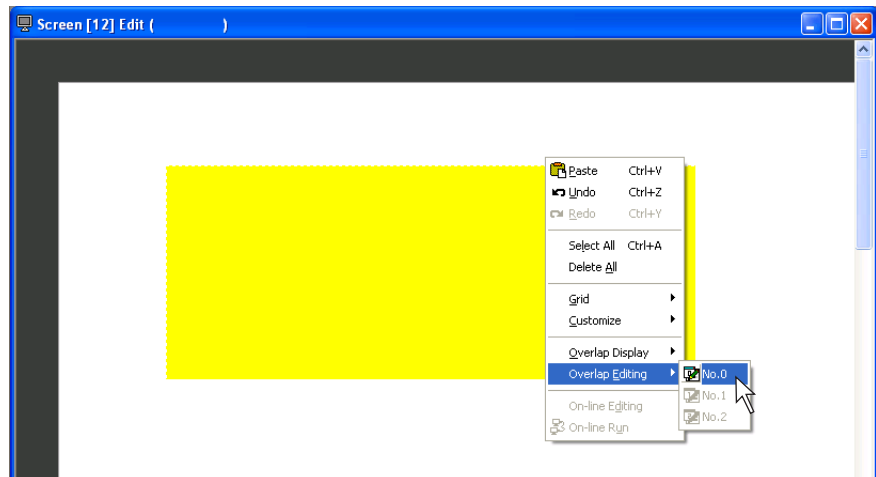

There are ways to start editing other than right-clicking. By selecting [View] → [Toolbar] → [Overlap] you can display the [Overlap] toolbar, which contains the [Overlap] icons. Clicking [No. 0] of these icons has the same effect as right-clicking.

3. The [Screen Edit] window switches to the [Overlap Edit] window.



4. Click the [Switch] icon to place the switch on the overlap display.



5. Make copies of the placed switch part, and place text on the switch parts.

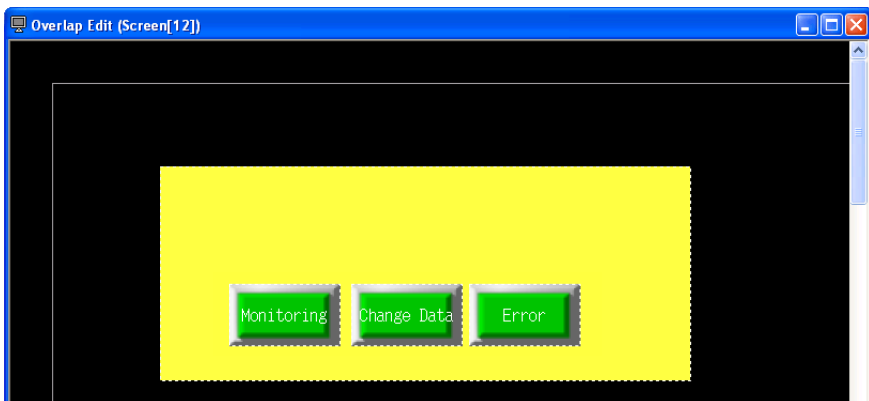



It is also possible to place an item without switching to the [Overlap Edit] window.

While the overlap display is selected, click the [Switch] icon and move the cursor to the screen. When the cursor is moved to the overlap display, click the mouse. A switch part is placed on the overlap display.

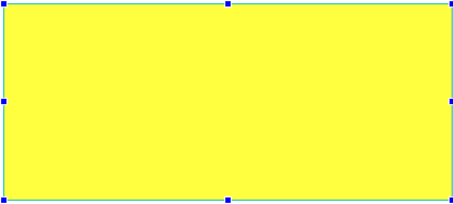

Select the overlap display.

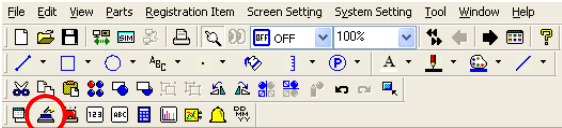

Place the switch part on the overlap display by moving the mouse.

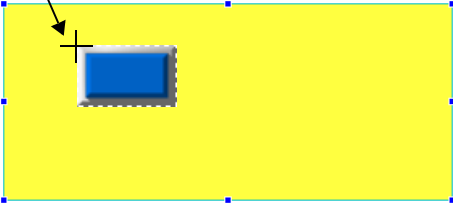



You can also select multiple items without switching to the [Overlap Edit] window. There are two methods for doing this.

One method for selecting is clicking the parts one by one while the [SHIFT] key is held down after selecting the overlap display.

The other method is clicking [Select within Overlap] in the right-click menu and dragging the mouse to select multiple parts in the overlap display area.

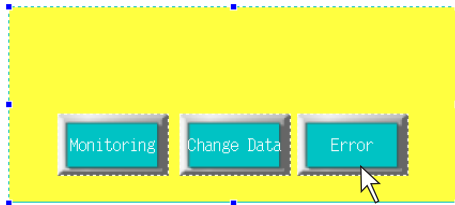

The overlap display part is selected by clicking the mouse once.

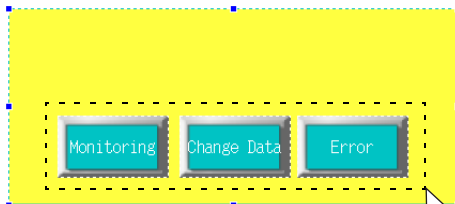
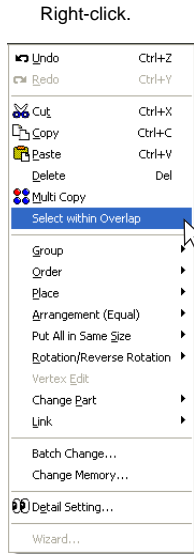

Select multiple parts on the overlap display at one time.

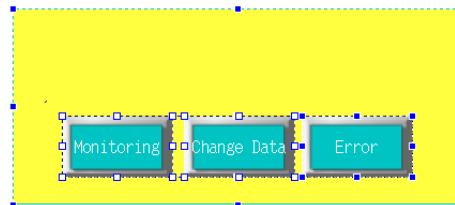

Multiple parts are selected.

- Next, place the text as a graphic on the overlap display.
Click the [Text] icon on the toolbar, and draw a box for text entry by dragging the mouse at the desired position on the overlap display.

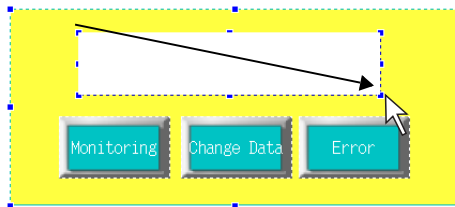
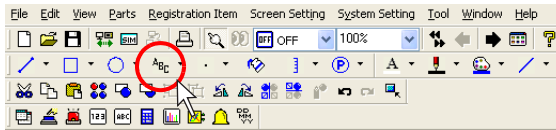

- The cursor is displayed on the box drawn in the step 6. Enter "MENU" and click any position other than the text box. The entered text is displayed on the screen.

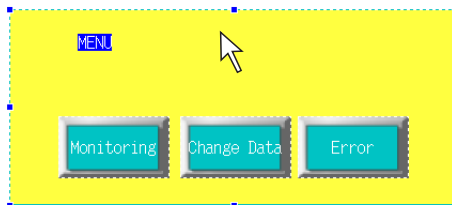

- When changing the size or the color, click (or double-click) the text to bring up the item dialog.

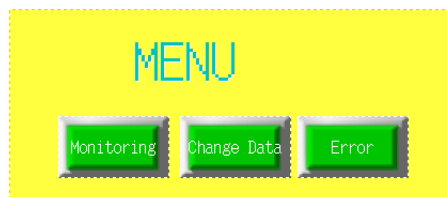

- When editing is completed, right-click → [Overlap Editing] → [No. 0] or click the [No. 0] in the overlap editing icons.
The former [Screen Edit] window is displayed.

The above step completes the overlap editing.

Multi-overlap (Call-overlap) Display

Placement procedure

The multi-overlap (or call-overlap) display is selected from the [Parts] menu or Catalog View. The actual overlap display is edited in the overlap library.

1. Click [Parts] → [Overlap] → [Multi-overlap].
The [Multi-overlap] icon appears on the screen.

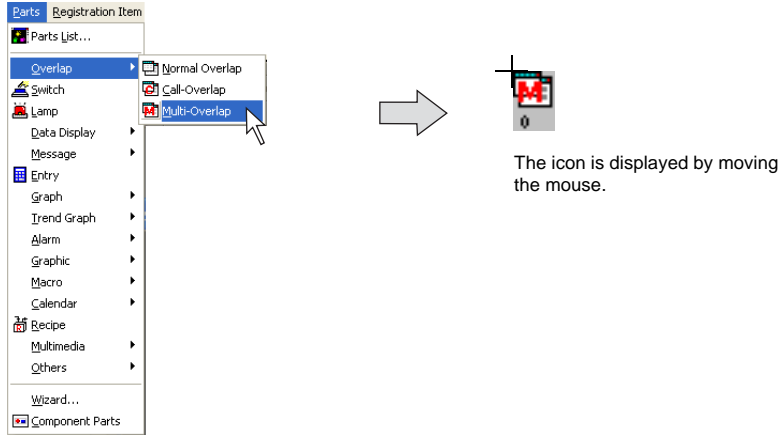

2. Click the mouse on the desired position. The multi-overlap icon is placed. The [Multi-overlap] item dialog is displayed at the same time.

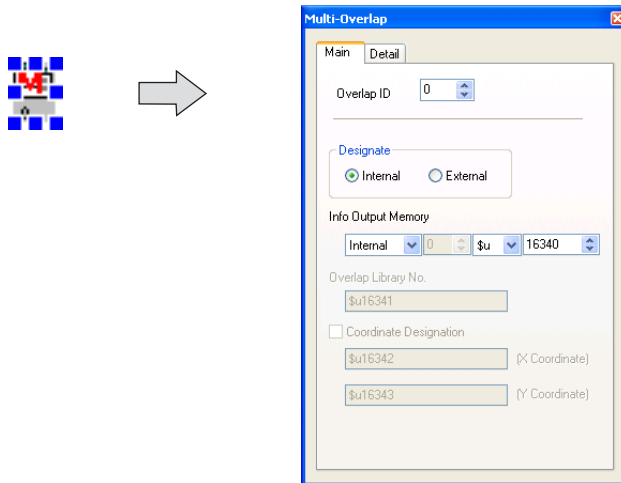

* When the item dialog is not displayed, double-click the multi-overlap display.

Overlap display placement and edit

The multi-overlap display is placed or edited using the “overlap library”. For more information on the “overlap library”, see page 4-45.

5 Transfer

This chapter describes the procedure for transferring the screen data between MONITOUCH and the editor.

5.1 Transfer Methods

Data can be transferred between MONITOUCH and the computer on which the editor is installed using a cable or card.

Data Transfer Method List

Transfer Method	MONITOUCH Model	
	V8i	V8
V-CP	○	○
Ethernet	○	△ *1
USB	○	○
CF card	○	○ *2
Memory card (= CREC)	○	○
Modem	○	○

*1 Possible only when the communication I/F unit "CU-03-3" is mounted.

*2 In the case of the V806 series, the optional unit "DU-10" or "USB-CFREC" is additionally required.

Using a Communication Cable

V-CP (Serial Port)

Connect MJ1 (modular jack for transfer) of MONITOUCH and the computer using Hakko Electronics' data transfer cable "V-CP".

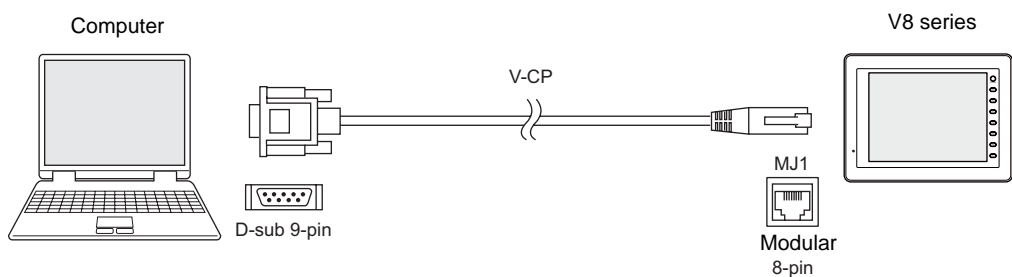

When the USB port is provided on the computer instead of the D-sub 9-pin serial interface, use a USB → D-sub 9-pin serial converter which is commercially available.

For the transfer procedure, see page 5-10.

Ethernet (LAN Port)

Connect the LAN port of MONITOUCH to the computer through an Ethernet connection (note that this applies to V8i only: with models other than V8i the optional communication I/F unit is necessary). Use a LAN cable. (Use a cross cable when establishing peer-to-peer network.)

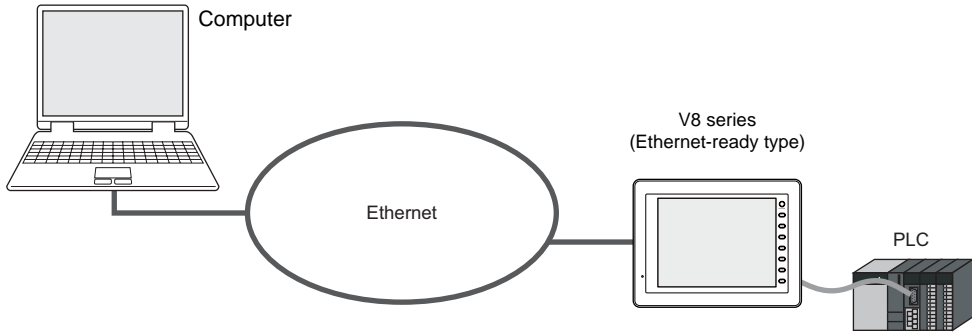

For the transfer procedure, see page 5-14.

USB (USB-B Port)

Connect the USB-B port at MONITOUCH and the USB-A port at the computer using a USB cable.

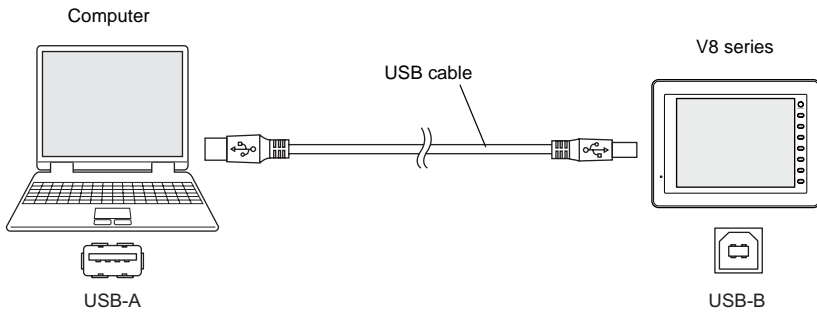

For the transfer procedure, see page 5-19.

Using a Card

CF Card

Data in the computer can be transferred to MONITOUCH using a CF card which is commercially available.

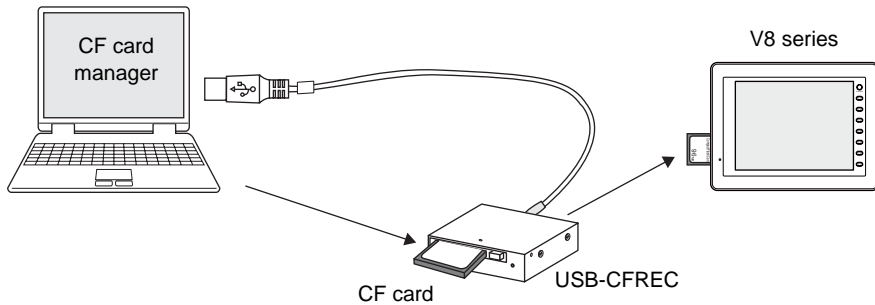

The appropriate environment to read from or write to the CF card is required on the computer side.

For the transfer procedure, see page 5-26.

Memory Card

Data in the computer can be transferred to MONITOUCH using Hakkro Electronics' "CREC" (card recorder) and "REC-MCARD" (memory card).

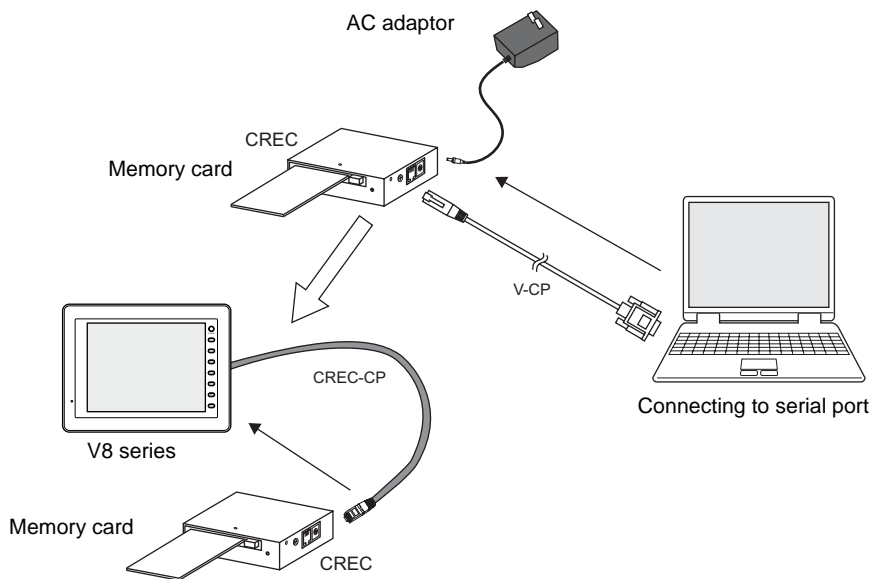

When connecting "CREC" (card recorder) and the computer, use the AC adaptor included with CREC as well as "V-CP".

For the transfer procedure, see page 5-32.

Using a Modem

Screen data can be transferred via telephone line.

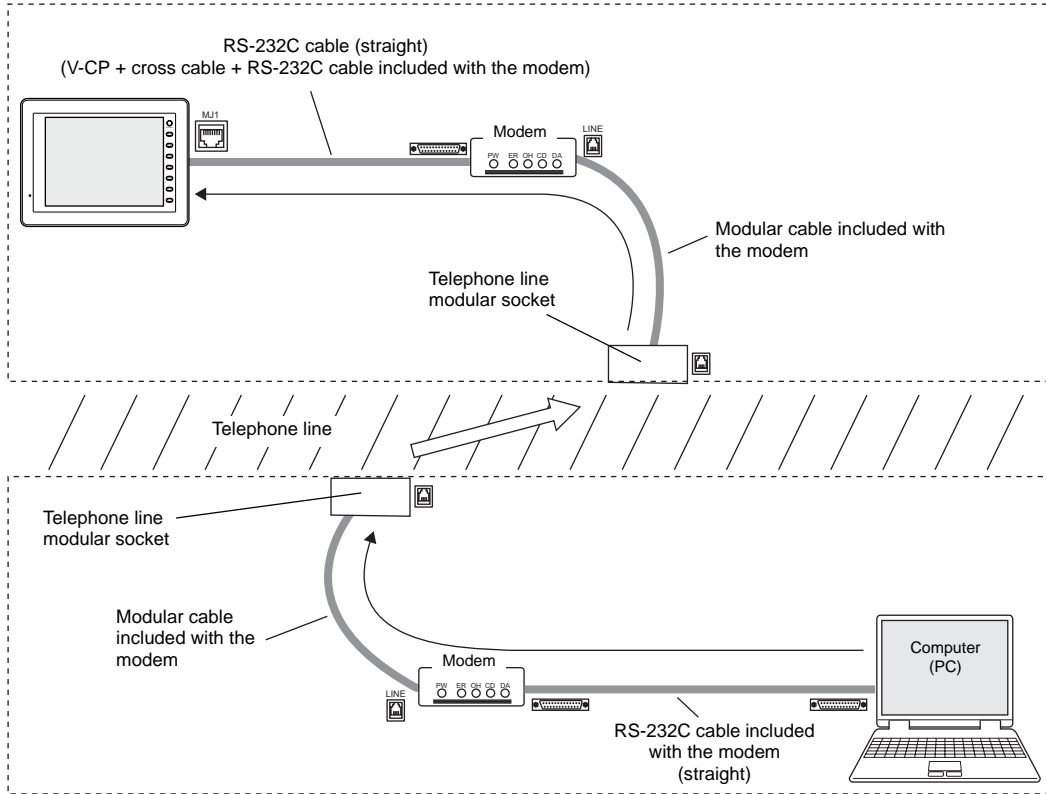

For more information, refer to the V8 Series Operation Manual.

5.2 Transfer Data

There are many kinds of data which can be transferred to MONITOUCH.

However, it is not necessary to worry about what kind of data to be transferred, except that of the screen data.

When [Screen Data] is selected and data transfer is started, other necessary data is automatically transferred together with the screen data.

Transfer Data List

Transfer Data	Contents
Screen Data (extension: "*.V8")	This is the screen data file of MONITOUCH.
I/F Driver (extension: "*.TPC")	This is the driver for communication. The driver file type varies depending on the model.
Display System Program (extension: "*.prg")	This is the system program file for MONITOUCH. This file is transferred to update the MONITOUCH program.
Font Data	This is the source file of fonts displayed on MONITOUCH. This file is automatically transferred when the screen data with a different font setting is transferred to MONITOUCH. The contents of the Main Menu screen are also updated by transferring this data.
SRAM Data (extension: "*.RAM")	This file is used when an SRAM cassette or a built-in SRAM is in use. It is transferred to make a backup copy of the SRAM data.
Station No. Table (extension: "*.dtmA")	This file is used when the station number table is used for Ethernet or temperature control network. This file is transferred to update the station number table.
Ladder Comm. Prg. (extension: "*.lcmA")	This is a program file used for the ladder transfer function.
Printer Driver (extension: "*.pdrA")	This is the printer driver used for the EPSON STYLUS PHOTO series.
Multi-link (extension: "*.MlpA")	This is a program file used for multi-link or multi-link2 connection.
Simulator program (UniPLC_*.tpc)	This is a program file used for the Simulator. There are three program files; for serial, USB and Ethernet communications. The applicable program file is automatically transferred during screen data transfer with [Use Simulator] checked.

System Program File

The following table shows the system program files corresponding to each MONITOUCH model.

MONITOUCH Model		Program File	
		Normal Mode	128-color Mode
V815iX		V8150.prg	-
V812(i)S / V810(i)S		V8120.prg	V81202.prg
V810(i)T		V8100.prg	V81002.prg
V810(i)C		V8100C.prg	V8100C2.prg
V808(i)S		V8080.prg	V80802.prg
V808(i)C	Landscape	V8080C.prg	V8080C2.prg
	Portrait	V8080CV.prg	-
V808(i)CH		V8080CH.prg	V8080CH2.prg
V806(i)T/V806(i)C	Landscape	V8060.prg	V80602.prg
	Portrait	V8060V.prg	-
V806M		V80602.prg	-

Normally, it is not necessary to transfer the files above.

They are transferred to update a program or the entire MONITOUCH system.



Do not turn the power off during transfer of a system program file. Doing so may cause an error on MONITOUCH.



To update the entire system, it is recommended to use [System Update].
In this case, however, executing [System Update] re-transfers the whole system file so you may have to transfer the screen data again.
As a basic procedure, transfer the screen data after executing [System Update].

5.3 Preliminaries

Preparation for MONITOUCH

The screen status before starting transfer varies between new MONITOUCH and the existing one.

New MONITOUCH

When a new MONITOUCH is started for the first time, the following screen appears.

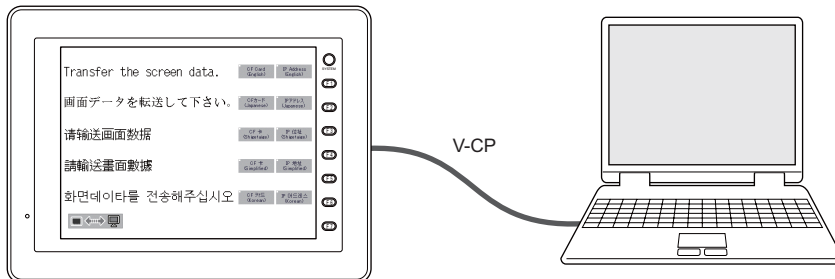

When transferring via V-CP or USB:

The data can be transferred from the screen shown above.

When transferring via Ethernet or a card:

Press the switch on the screen and bring up each setting menu or transferring screen.

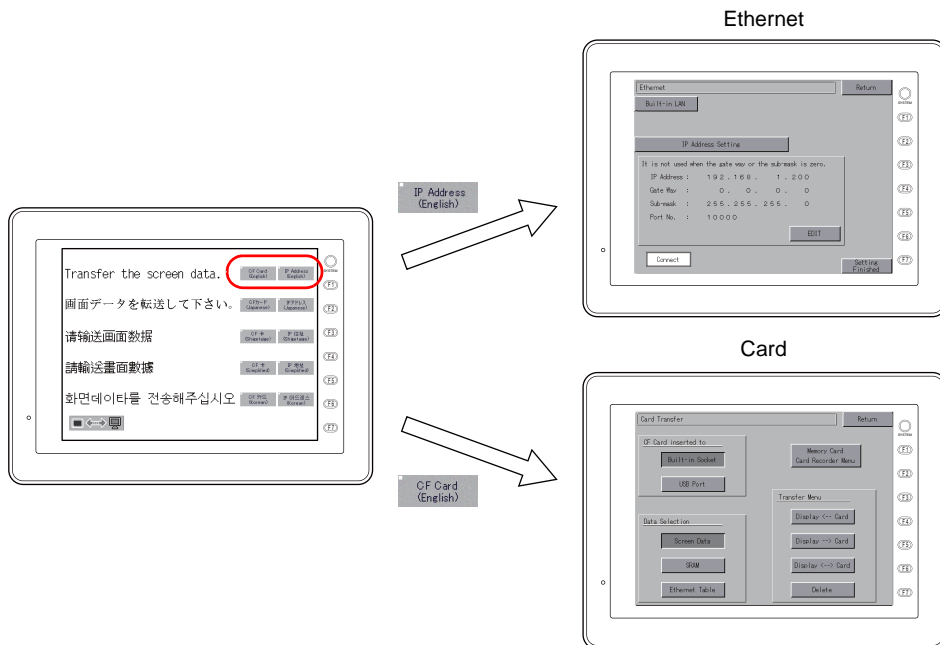

Existing MONITOUCH

When the existing MONITOUCH is started, it is in a RUN state.

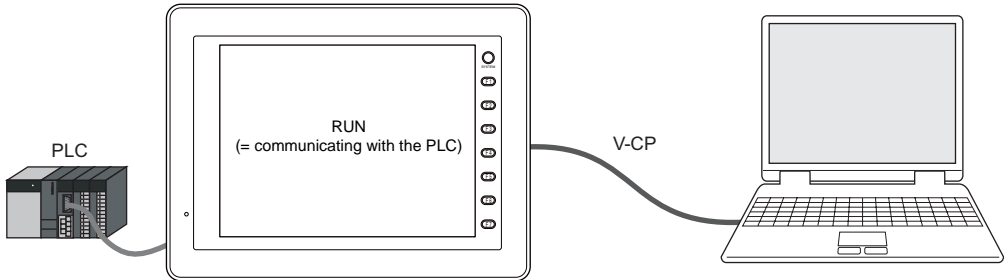

The data can be transferred in the RUN mode or after the Main Menu screen is displayed.

When transferring via V-CP:

When [No connection] is indicated at [MJ1] for the screen data that has been transferred to MONITOUCH before, the data can be transferred even in the RUN mode.

However, if a setting other than [No connection] is set for [MJ1], you must bring up the Main Menu screen before starting the transfer.

 To display the Main Menu screen:
Press the [SYSTEM] switch. When the menu is displayed, press the [F1] switch. Then the Main Menu screen is displayed.

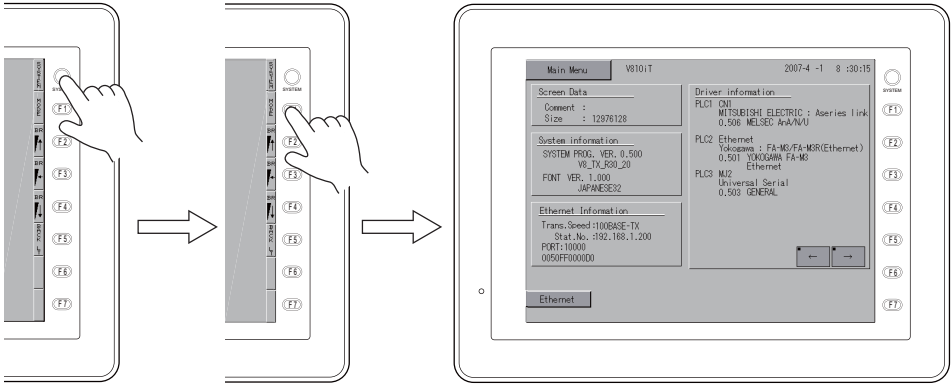

The diagram shows three stages of the process: 1. A hand pressing the [SYSTEM] switch on the terminal's control panel. 2. A hand pressing the [F1] switch. 3. The terminal screen displaying the 'Main Menu' with various system and driver information.

Main Menu		V8101T		2007-4 -1 8 :30:15	
Screen Data		Driver information		[F1]	
Comment :	PLC1 DM	MITSUBISHI ELECTRIC : Aseries link		[F2]	
Size :	12978128	0.508 MELSEC AxA/VXU		[F3]	
System information		PLC2 Ethernet		[F4]	
SYSTEM PROG. VER.:	0.500	Yokogawa : FA-ME/FA-MBR(Ethernet)		[F5]	
VB_TX_R50_20		0.201 YOKOGAW FA-ME		[F6]	
FONT VER.:	1.000	PLC3 M12 Ethernet		[F7]	
JAPANESE12		Universal Serial			
Ethernet Information		0.500 GENERAL			
Trans.Speed:	1100BASE-TX				
Stat.No.:	-192.168.1.200				
PORT:	100000				
	0056FF000000				
Ethernet					

If the screen is not changed by pressing the [SYSTEM] or [F1] switch, the switch may be prohibited or set to become active when the switch is held down for a certain time.
For details, refer to the chapter on function switches in the Hardware Specifications manual for each MONITOUCH model.

When transferring via USB:

The screen data can be transferred in the RUN mode as well as from the Main Menu screen.

When transferring via Ethernet:

When the IP address or subnet mask is correctly set for Ethernet transfer, the screen data can be transferred in the RUN mode as well as from the Main Menu screen.

However, it is necessary to display the Ethernet screen opened from the Main Menu screen when checking or changing the current setting.

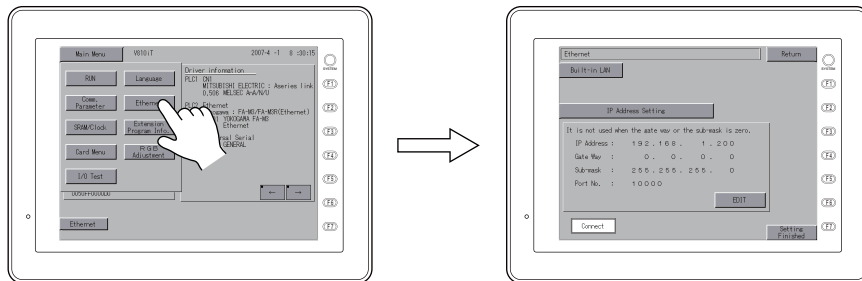

When using a card:

To transfer data using a CF card or memory card, display the Card Transfer screen opened from the Main Menu screen.

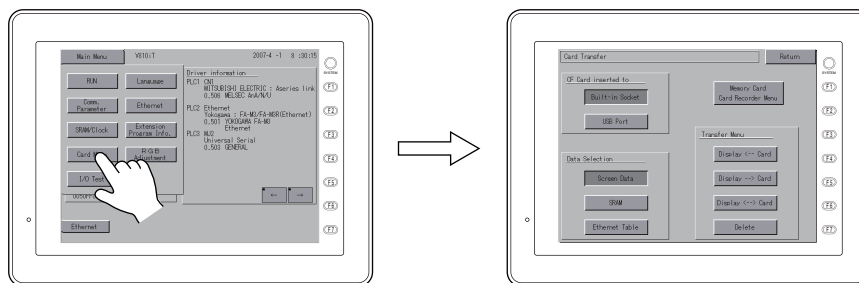

- * In the case of the automatic uploading using a CF card, it is not necessary to display the Main Menu screen. For more information on the automatic uploading, refer to “Chapter 18 CF Card” in the V8 Series Reference Manual.

Preparation for Peripheral Equipment

Depending on the transfer method, it is necessary to prepare peripheral equipment (LAN cable, CF card, etc.) in addition to MONITOUCH and accessories included with MONITOUCH. Please prepare equipment which is commercially available near you if it is not required to use dedicated equipment.

5.4 Transfer Procedure (Using a Communication Cable)

V-CP

System Configuration

The data is transferred in the following system configuration using V-CP.

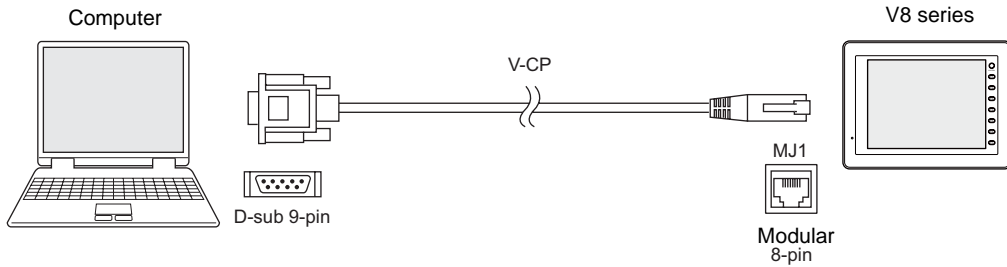

Transfer Procedure from the Editor to MONITOUCH

1. Connect MONITOUCH (MJ1) and the computer using V-CP.

E.g. V810iT

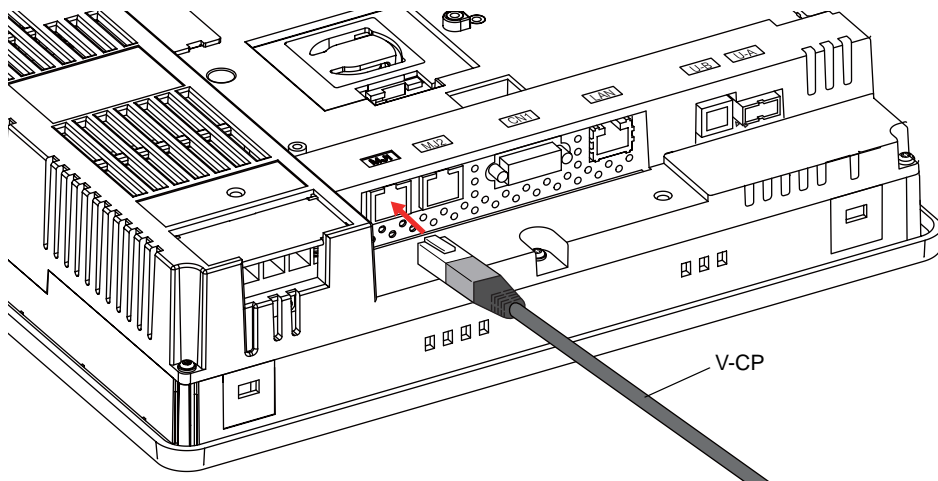

When [No connection] is not set for the MJ1, display the Main Menu screen on MONITOUCH.

2. On the editor, open the screen data to be transferred.

- Click [File] → [Transfer] or click the [Transfer] icon on the toolbar.

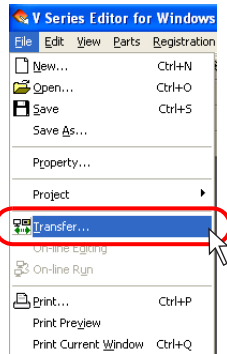

OR

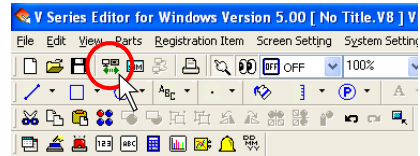

- The [Transfer] dialog is displayed. Select [Display] for [Transfer Device], and [Screen Data] for [Transfer Data]. Leave Use Simulator unchecked at this time. (When using the Simulator, check this box.)

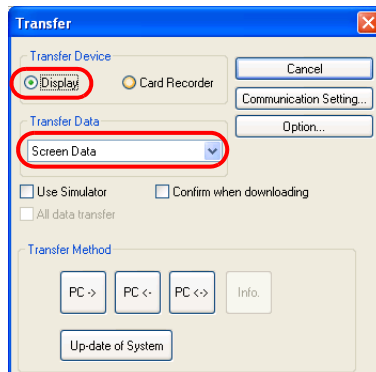

- Click the [Communication Setting] button. The [Communication Setting] dialog is displayed.

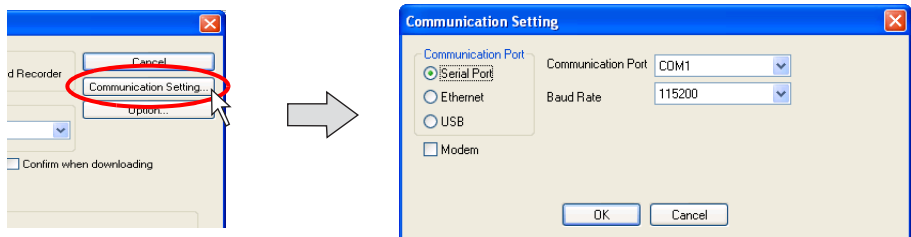

- Select [Serial Port] for [Communication Port].

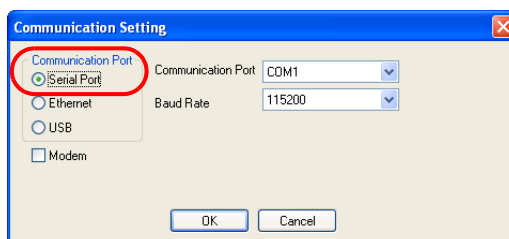

7. For [Communication Port], select the port used for connecting V-CP on the computer.
(When using the USB-serial converter, select the COM port set for the USB port.)

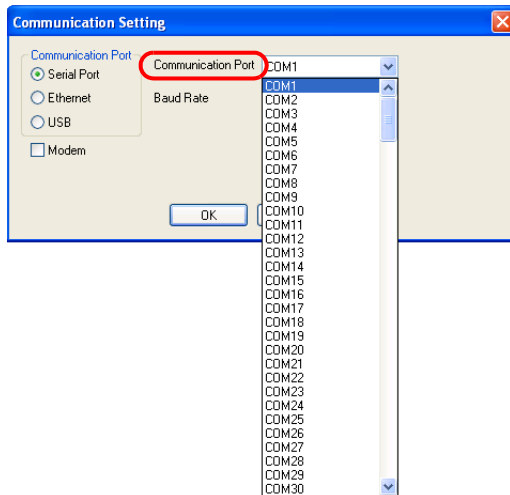

8. Specify the baud rate for [Baud Rate].
The default setting is [57600] bps. [115200] bps is available depending on the computer.
Check the available rate, and specify its maximum rate.

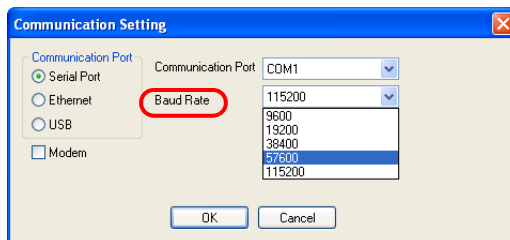

9. When settings has been made, click [OK]. The [Transfer] dialog is displayed again.

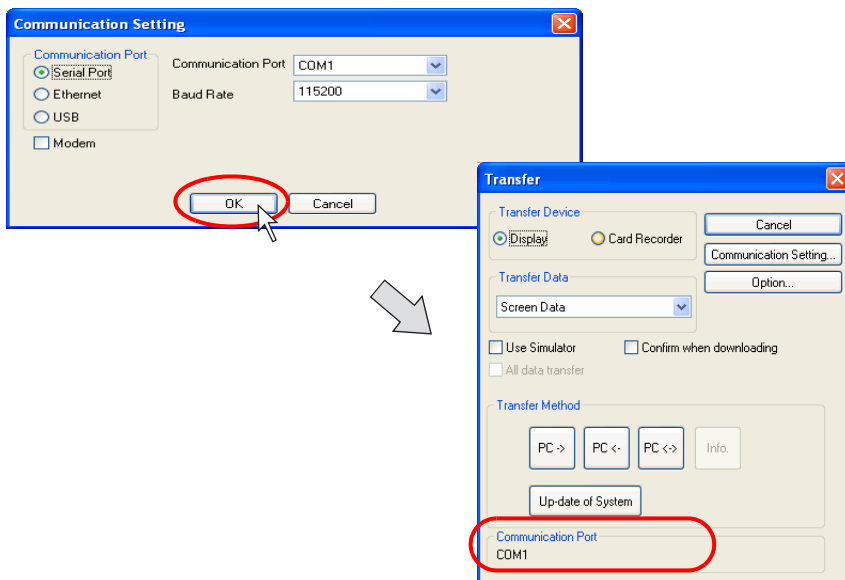

10. Click the [PC ->] button. Data transfer is started.

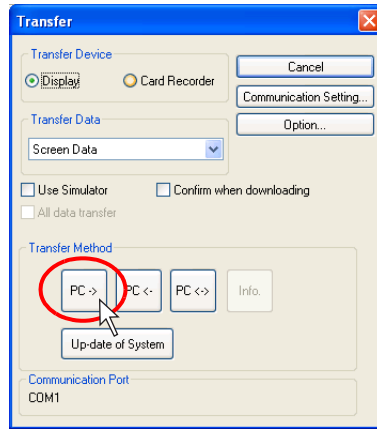

11. During data transfer, the following dialog is displayed.

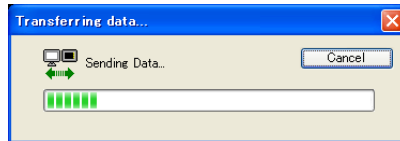

On MONITOUCH, the screen is changed to the Main Menu screen shown below.

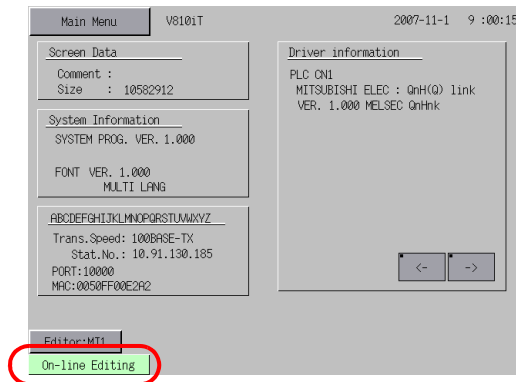

12. When the data transfer is completed, the display indicating that the data transfer is in process disappears.

Data transfer has been completed.

Ethernet

System Configuration

The data is transferred in the following system configuration via Ethernet.

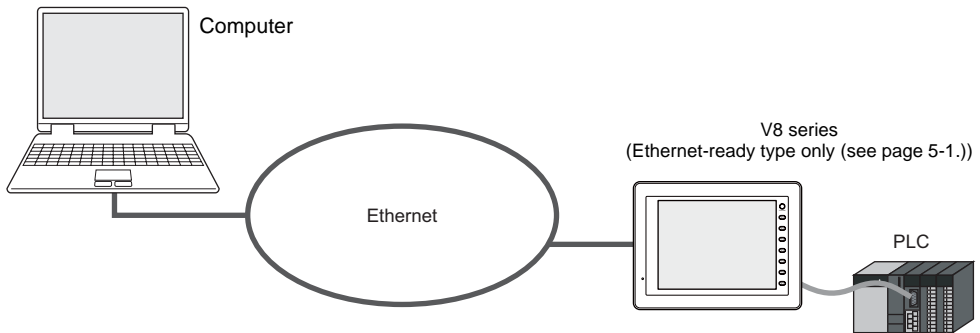

Transfer Procedure from the Editor to MONITOUCH

1. Connect the LAN port of MONITOUCH (or LAN port of CU-03-3) and the computer using a LAN cable.

E.g. V810iT (LAN port)

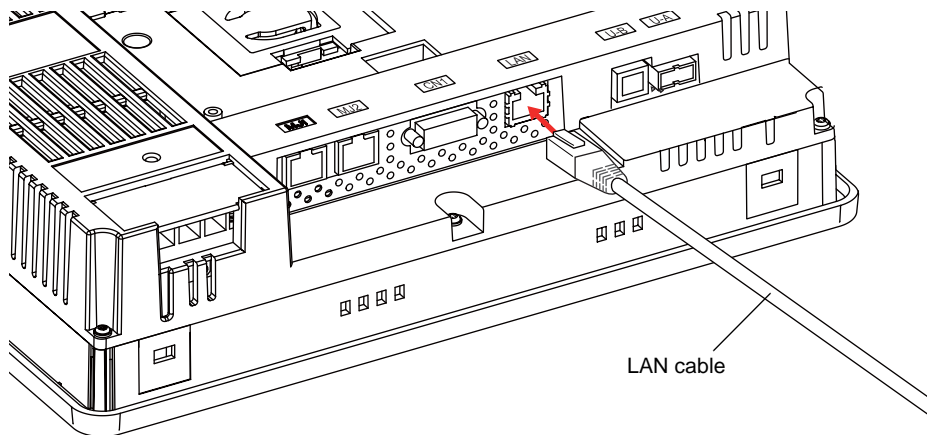

Please provide your own LAN cable.
When connecting a LAN cable to the hub, provide a straight cable. When connecting it to the computer directly, provide a cross cable.

- If possible, check the setting, such as connecting status or IP address setting, on the Main Menu screen.

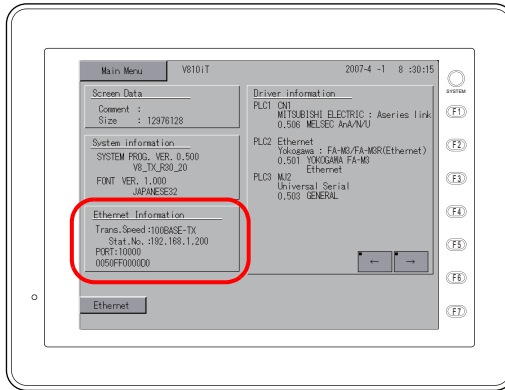

- On the editor, open the screen data to be transferred.
- Click [File] → [Transfer] or click the [Transfer] icon on the toolbar.

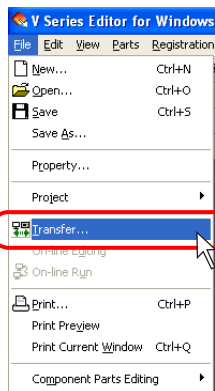

OR

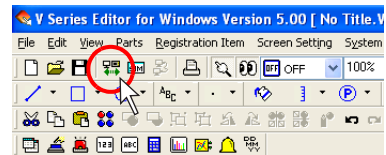

- The [Transfer] dialog is displayed. Select [Display] for [Transfer Device], and [Screen Data] for [Transfer Data].

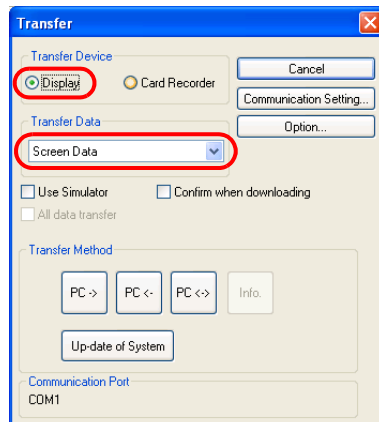

- Click the [Communication Setting] button.
The [Communication Setting] dialog is displayed.

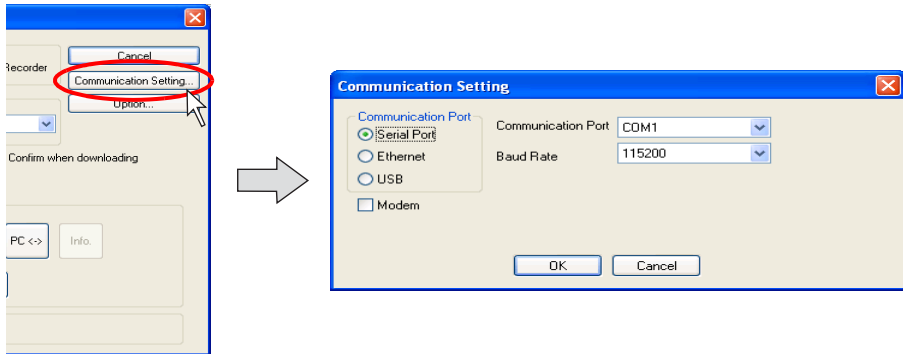

- Select [Ethernet] for [Communication Port].

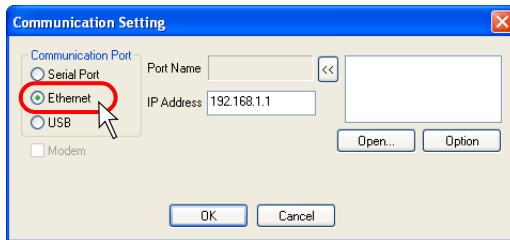

Specify the IP address of MONITOUCH for [IP Address].

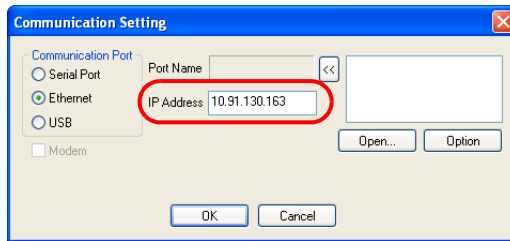

When the Ethernet table has been set for the screen data, the table contents are displayed in the upper right field.

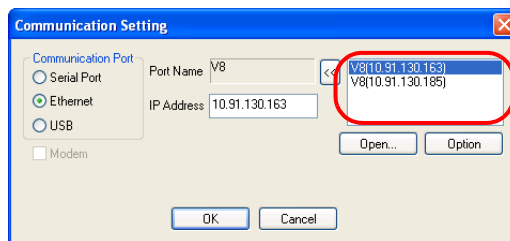

The IP address of the transfer target can also be selected from the table. Select the target IP address and click the [<<] button. The IP address is set in the [IP Address] field.

8. When settings has been made, click [OK]. The [Transfer] dialog is displayed again.

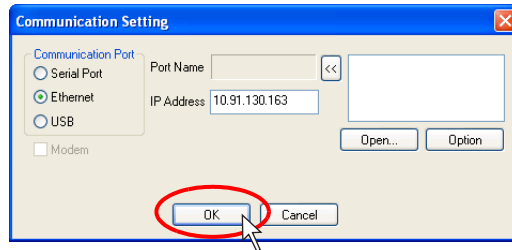

9. Click the [PC ->] button. Data transfer is started.

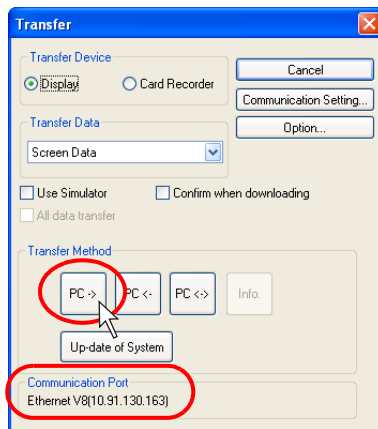

10. During data transfer, the following dialog is displayed.

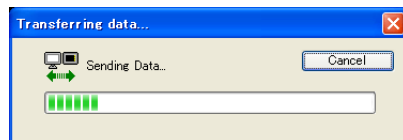

On MONITOUCH, the screen is changed to the Main Menu screen shown below.

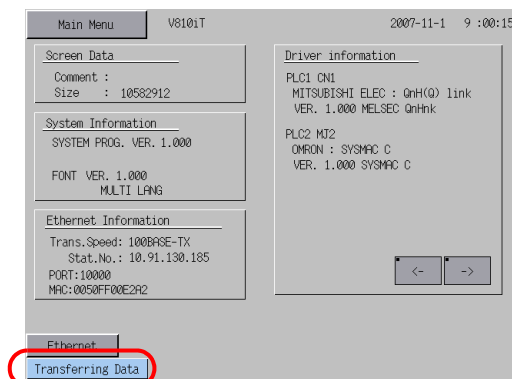

11. When the data transfer is completed, the display indicating that the data transfer is in process disappears.

Data transfer has been completed.



To check if the Ethernet connection is correctly established, send a "PING" command from the computer.

<Checking method using "PING">

E.g.: When the IP address of MONITOUCH is set as "172.16.200.150": Check on the computer if the connection is correctly established.

Launch "Command Prompt" on Windows.

```
Microsoft Windows XP [Version 5.1.2600]
(C) Copyright 1985-2001 Microsoft Corp.
C:\Documents and Settings\KAERIVAMA>
```

Key-in "PING 172.16.200.150" and press the [ENTER] key.

```
Microsoft Windows XP [Version 5.1.2600]
(C) Copyright 1985-2001 Microsoft Corp.
C:\Documents and Settings\KAERIVAMA>ping 10.91.130.163_
```

When the connection is established, the following results are shown.

Connection
OK

```
Microsoft Windows XP [Version 5.1.2600]
(C) Copyright 1985-2001 Microsoft Corp.
C:\Documents and Settings\KAERIVAMA>ping 10.91.130.163
Pinging 10.91.130.163 with 32 bytes of data:
Reply from 10.91.130.163: bytes=32 time=1ms TTL=128
Reply from 10.91.130.163: bytes=32 time=1ms TTL=128
Reply from 10.91.130.163: bytes=32 time<1ms TTL=128
Reply from 10.91.130.163: bytes=32 time=1ms TTL=128

Ping statistics for 10.91.130.163:
    Packets: Sent = 4, Received = 4, Lost = 0 (0% loss),
    Approximate round trip times in milli-seconds:
        Minimum = 0ms, Maximum = 1ms, Average = 0ms
C:\Documents and Settings\KAERIVAMA>
```

When the connection is not established, the following results are shown.

Not
connected

```
Microsoft Windows XP [Version 5.1.2600]
(C) Copyright 1985-2001 Microsoft Corp.
C:\Documents and Settings\KAERIVAMA>ping 10.91.130.163
Pinging 10.91.130.163 with 32 bytes of data:
Request timed out.
Request timed out.
Request timed out.
Request timed out.

Ping statistics for 10.91.130.163:
    Packets: Sent = 4, Received = 0, Lost = 4 (100% loss),
C:\Documents and Settings\KAERIVAMA>
```

USB

System Configuration

The data is transferred in the following system configuration via USB.

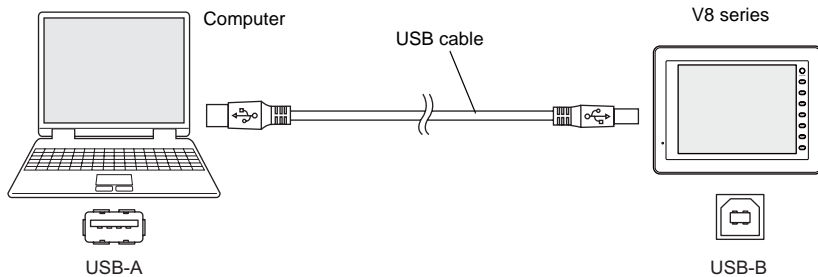

Before Transfer via USB

Installing the USB driver

As an example, the installation procedure on Windows XP is described below.

* **When using USB on Windows 98, Windows 98 Second Edition or later is required.**

1. Connect the USB-B port of MONITOUCH (with the power on) to the computer (with the power on) using a USB cable.
2. The message "Found New Hardware" and then the driver installation wizard appear on the computer. Select [No, not this time] and click the [Next] button.

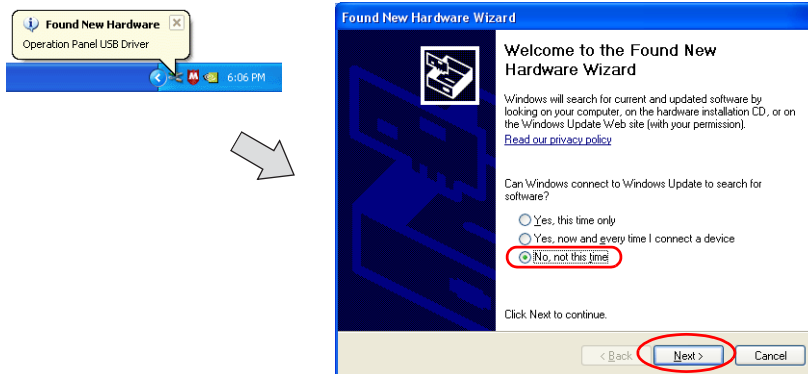

3. The dialog below is displayed. Select [Install from a list or specific location], and click the [Next] button.

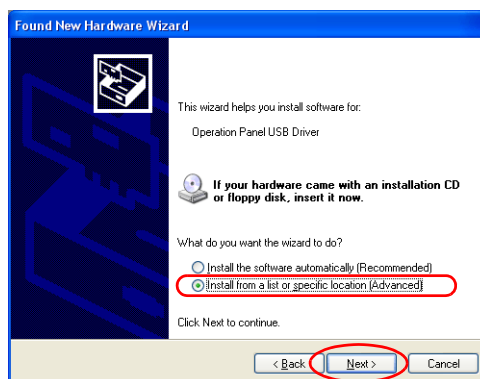

4. The following dialog is displayed. Select [Don't search. I will choose the driver to install.], and click the [Next] button.

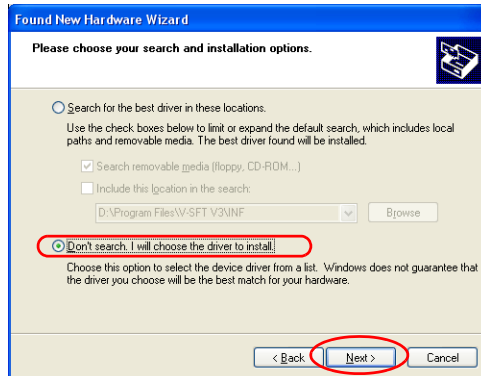

5. The dialog below is displayed. Click the [Next] button.

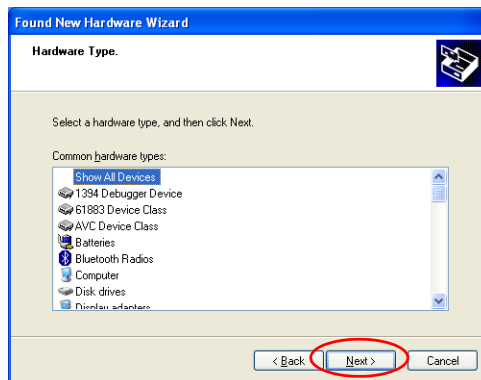

6. The following dialog is displayed. Click [Have Disk] button.

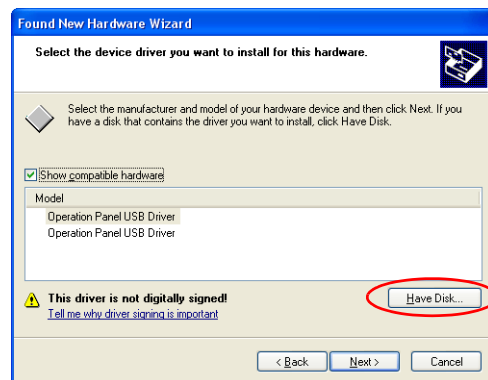

7. The [Install From Disk] dialog is displayed. Click [Browse] button.

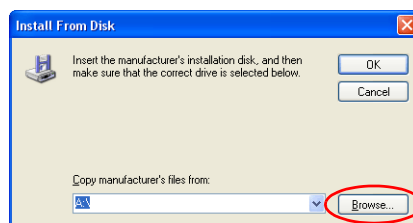

8. The USB driver "OP-U.inf" is automatically stored in the installation folder within the V-SFT-5 editor ("INF" folder in the V-SFT V5 as an example).



The USB driver to be installed varies, depending on the OS installed on your computer. Be sure that the driver is correct.

Select the "OP-U.inf" file and click the [Open] button.

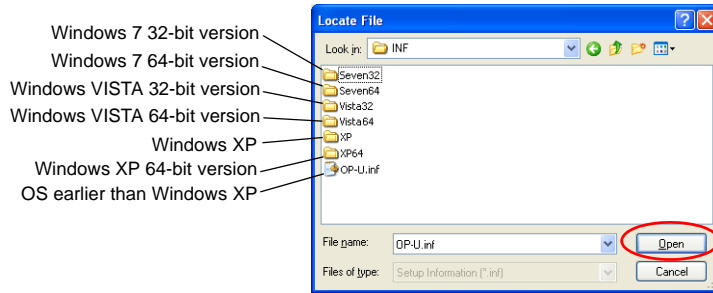

9. The previous dialog is displayed again. Check the path shown under [Copy manufacturer's files from:] and click [OK].

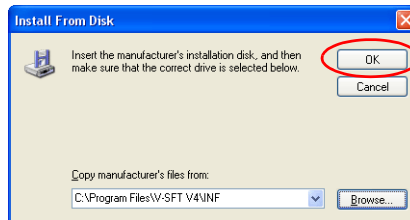

10. The following dialog is displayed. Check that [Operation Panel USB Driver] is shown under [Model]. Click [Next].

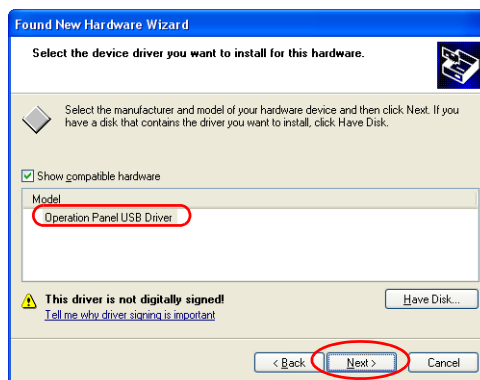

11. The driver installation is started.

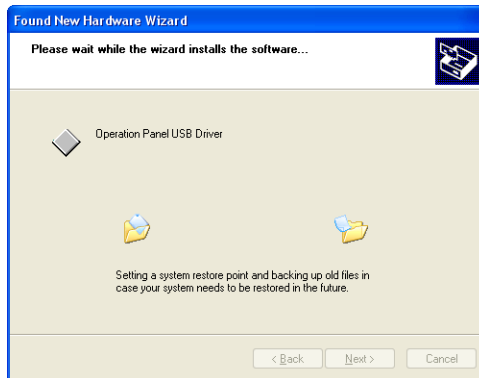

12. The dialog shown below is displayed on completion of installation. Click [Finish].

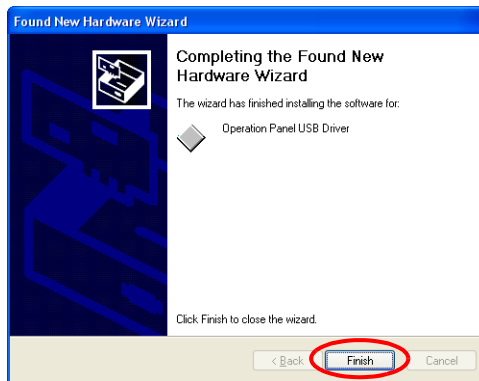

USB driver recognition

When the driver has been installed successfully, the [Device Manager] window shows “Operation Panel - Operation Panel USB Driver”.

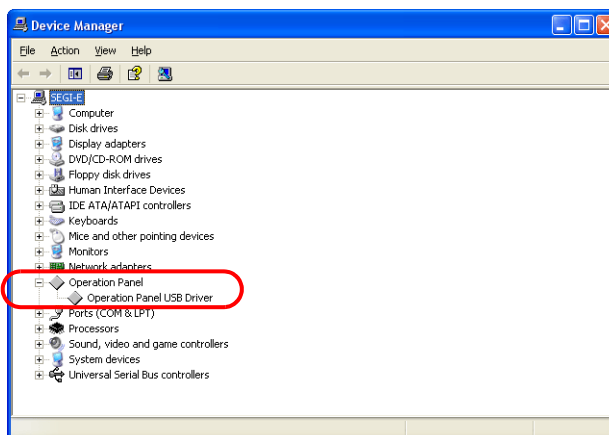

This option disappears when MONITOUCH is disconnected from the computer.

If [Other Device] or [?] is shown even while the connection via USB is maintained, the USB driver is not recognized. If this occurs, uninstall the USB driver once and reinstall it.

Transfer Procedure from the Editor to MONITOUCH

1. Connect MONITOUCH (USB-B) and the computer using a USB cable.

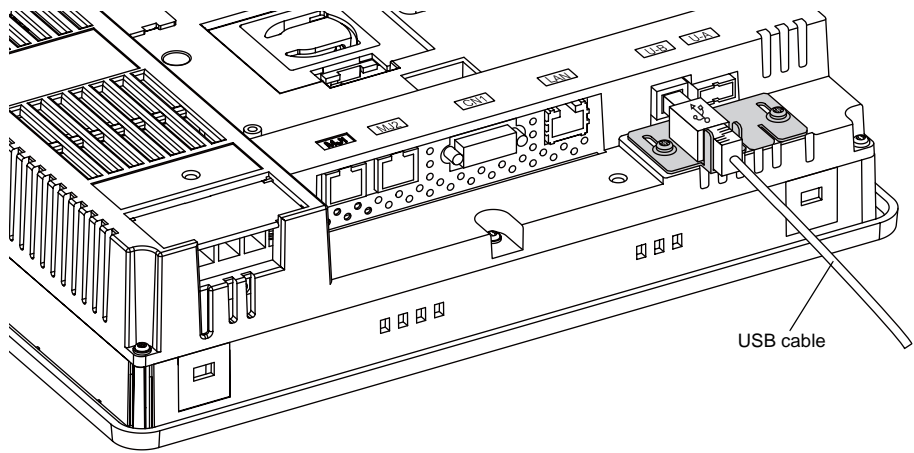

2. Click [File] → [Transfer] or click the [Transfer] icon on the toolbar.

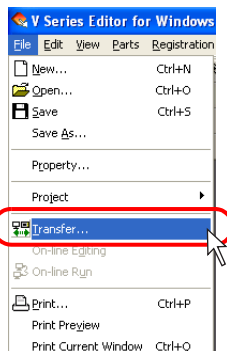

OR

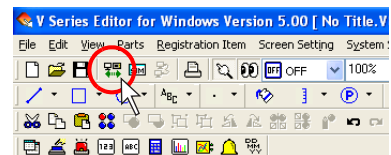

3. The [Transfer] dialog is displayed.
Select [Display] for [Transfer Device], and [Screen Data] for [Transfer Data].
Leave Use Simulator unchecked at this time.
(When using the Simulator, check this box.)

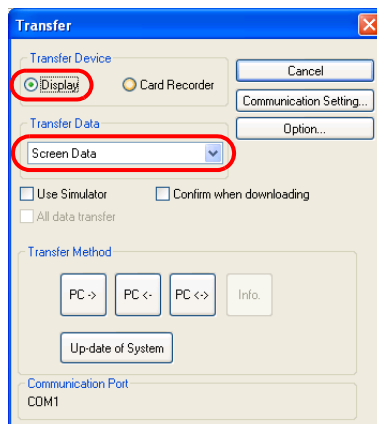

4. Click the [Communication Setting] button.
The [Communication Setting] dialog is displayed.

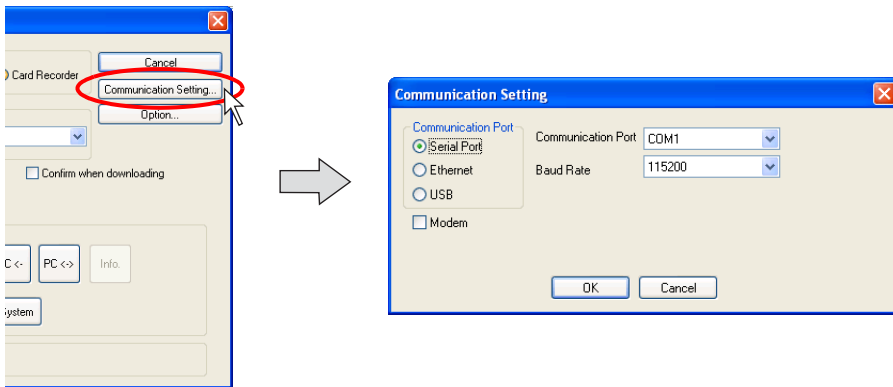

5. Select [USB] for [Communication Port].

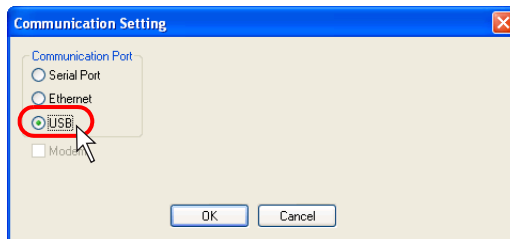

6. On completion of setting, click [OK]. The [Transfer] dialog is displayed again.
7. Click the [PC ->] button. Data transfer is started.

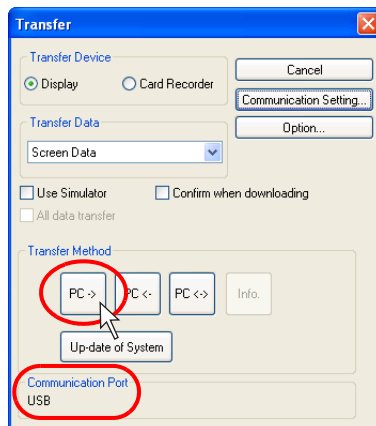

8. During data transfer, the following dialog is displayed.

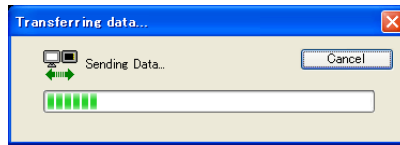

On MONITOUCH, the screen is changed to the Main Menu screen shown below.

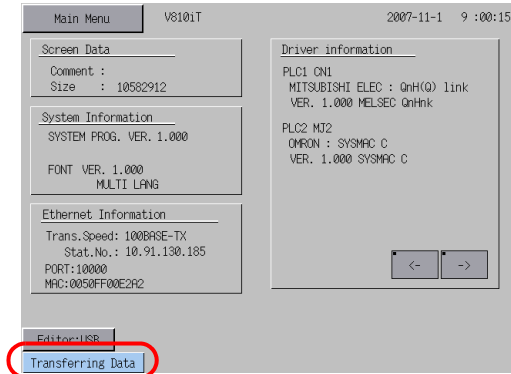

9. When the data transfer has been completed, the display indicating that the data transfer is in process disappears.

Data transfer has been completed.

5.5 Transfer Procedure (Using a Card)

CF Card

System Configuration

The data is transferred in the following system configuration using a CF card.

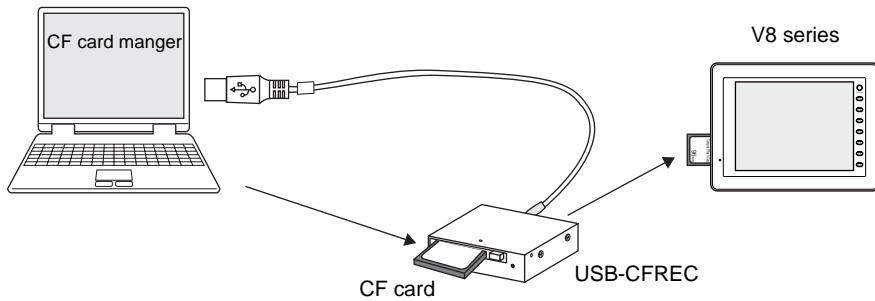

Transfer Procedure from the CF card to MONITOUCH

When a memory card is used, data is transferred following the procedure described below.

1. Transfer from the editor to the CF card (CF card manager)
2. Transfer from the CF card to MONITOUCH



Conversely, to transfer the data from the CF card to MONITOUCH, follow the two steps described below.

1. Transfer from the CF card to MONITOUCH
2. Transfer from the editor to the CF card (CF card manager)

1. Transfer procedure from the editor to the CF card (CF card manager)

1. Insert (or connect) the CF card into the computer.

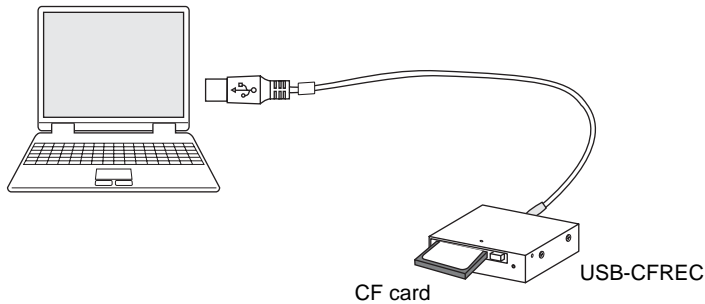

Check the drive allocation for the CF card in advance.
(In the example, "G" is allocated to the CF card drive.)

2. Click [File] → [CF Card Manager].

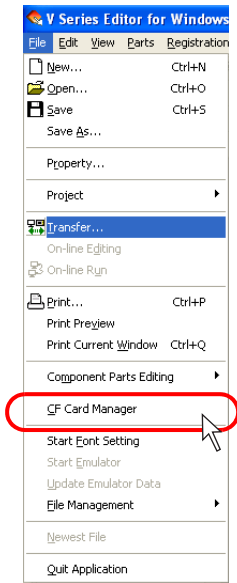

3. The dialog for specifying the drive is displayed.
Specify the drive that you have checked in step 1. (e.g. G drive), click [OK].

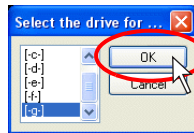

4. The [CF Card Manager] window is displayed.

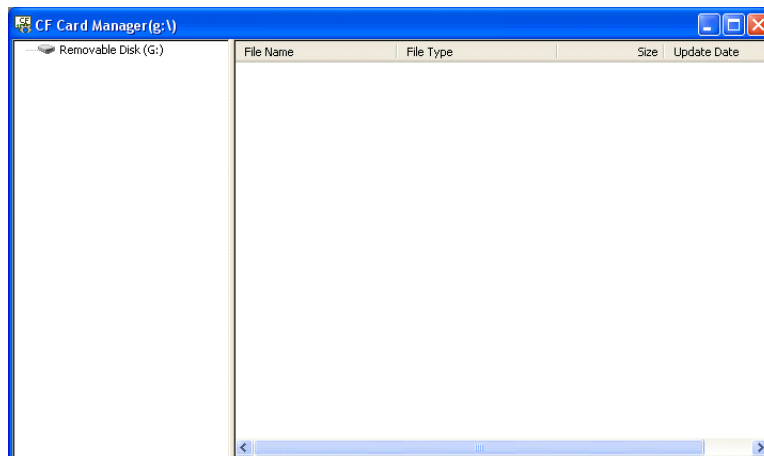

5. Click [File] → [Write to CF Card].
The [Write to CF Card] dialog is displayed.

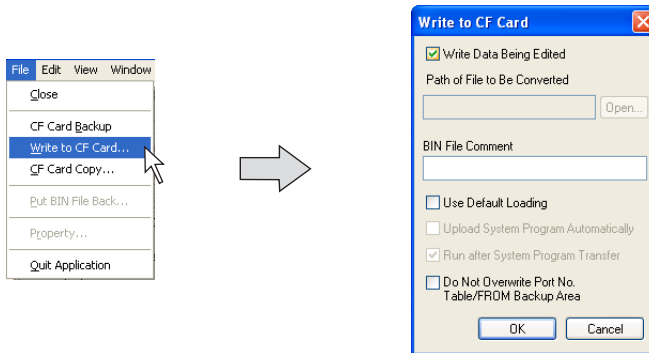

6. When transferring the data currently opened, check [Write Data Being Edited].
When selecting the screen data file as desired, uncheck [Write Data Being Edited], and click the [Open] button for [Path of File to Be Converted].

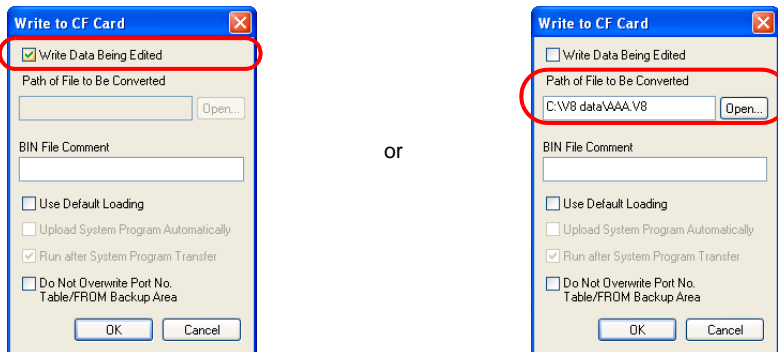

7. Click [OK].
The data is written to the CF card.

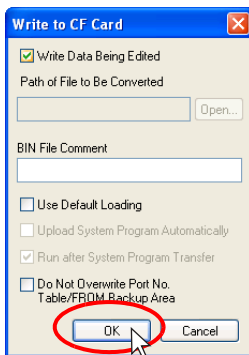

8. When writing is completed, the access folder is automatically created in the CF card. In the "DSP" folder created in the access folder, you can find that the [DSP0000.BIN] file is newly created.

This "DSP0000.BIN" file is the screen data file.

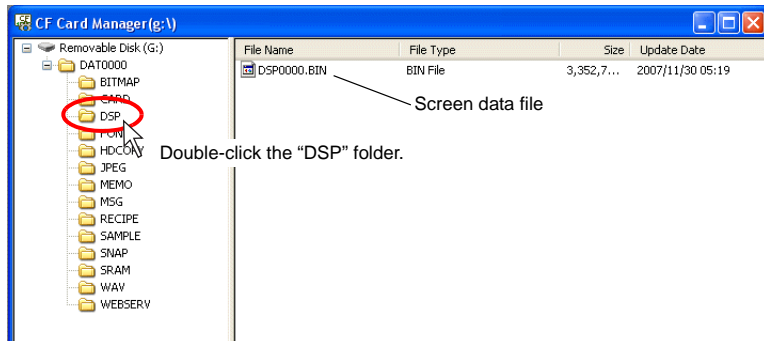
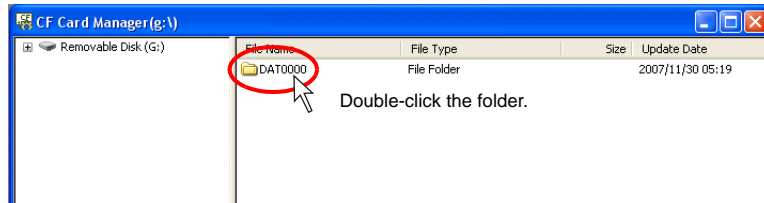

2. Transfer procedure from the CF card to MONITOUCH

1. Display the Main Menu screen on MONITOUCH.

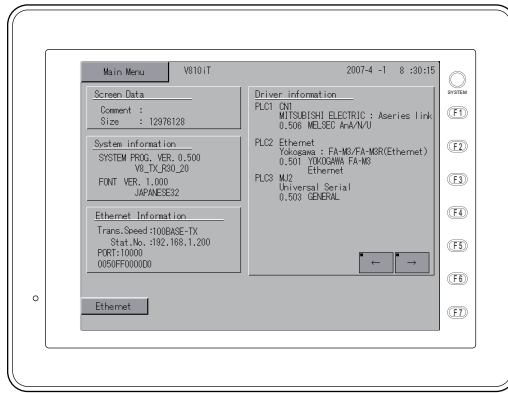

To display the Main Menu screen:

Press the [SYSTEM] switch. When the menu is displayed, press the [F1] switch. Then the Main Menu screen is displayed.

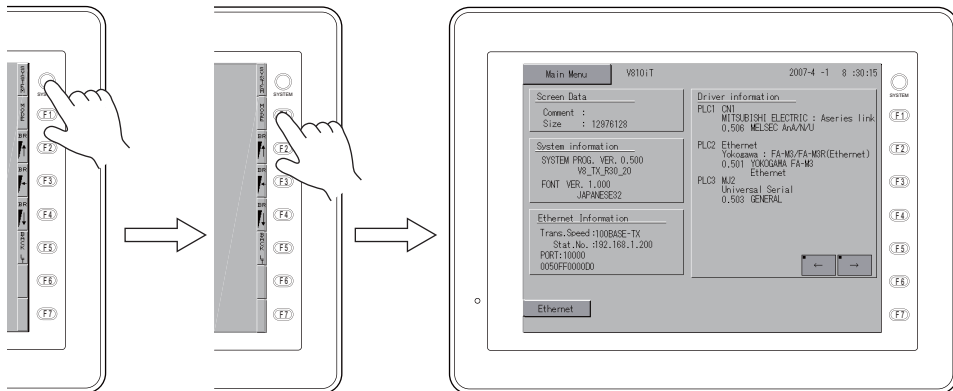

If the screen is not changed by pressing the [SYSTEM] or [F1] switch, the switch may be prohibited or set to become active when the switch is held down for a certain time. For details, refer to the chapter on function switches in the Hardware Specifications manual for each MONITOUCH model.

2. Insert the CF card that contains the screen data into MONITOUCH.

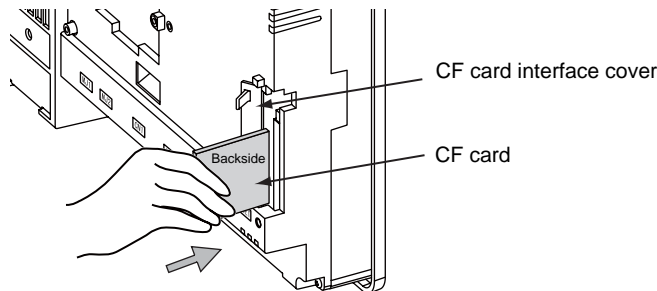

* Check the orientation of the CF card.

- At MONITOUCH, press the [Main Menu] switch then the [Card Menu] switch. The Card Transfer screen is displayed.

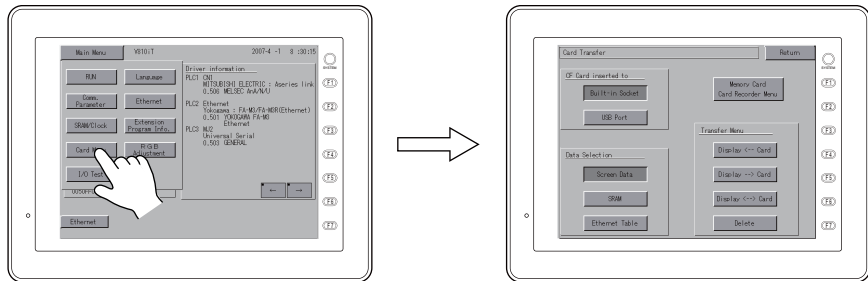

- Set [Data Selection: Screen Data] and [CF Card inserted to: (As Desired)]. Press the [Display <--- Card] switch. The [CF Card File Information] window is displayed.

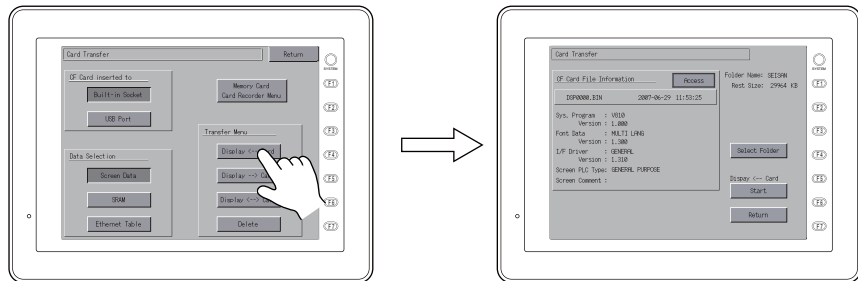

- When the name of the access folder created in the CF card is shown as [Folder Name], go to the next step. (go to step 6.)
When the target folder name is not displayed at [Folder Name], press the [Select Folder] switch and select the target folder.

When the target folder name is not displayed:

Select the target folder.

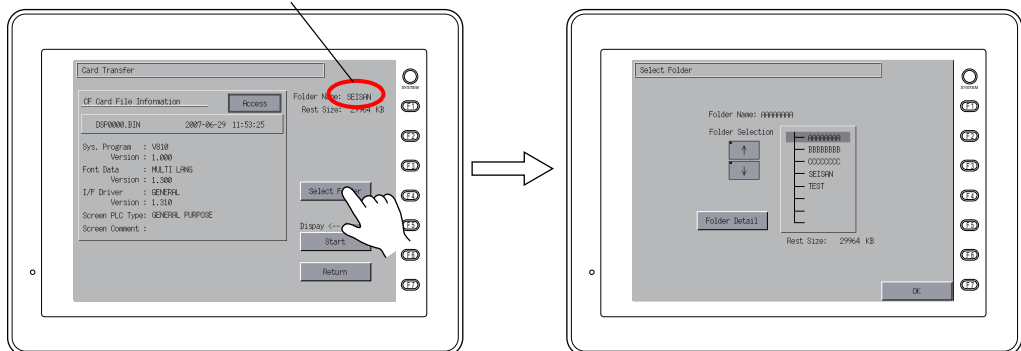

Press the [Select Folder] switch.

5.5 Transfer Procedure (Using a Card)

- Press the [Select Data] switch.
The [Data Selection] dialog is displayed, and at the same time the text on the [Select Data] switch changes to [Start].

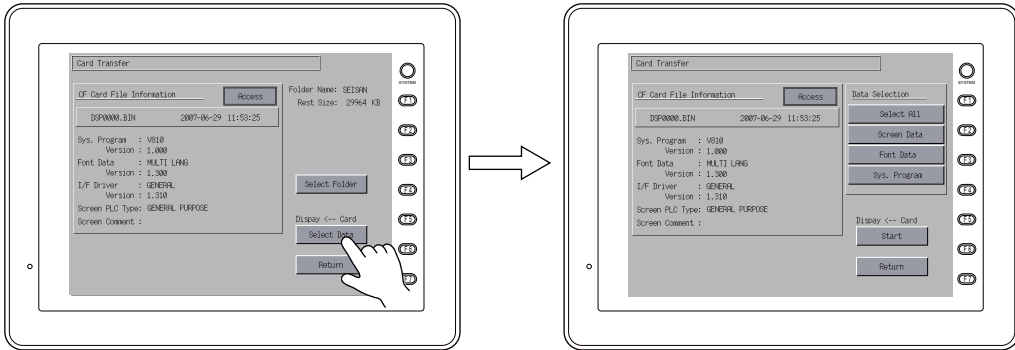

- Select the data to be transferred. In this example, press [Select All] switch so that all data will be transferred.
Press the [Start] switch. The text on the [Start] switch changes to [Transferring].

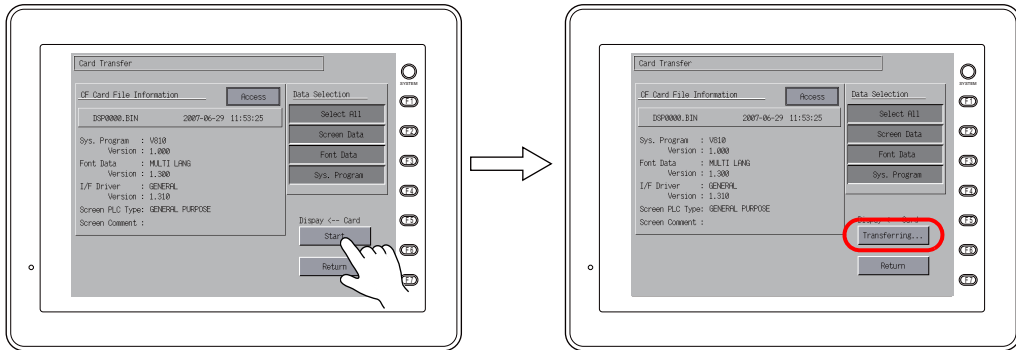

- When the data has been transferred successfully, the Main Menu screen is displayed again.

☺ When [Select All] or [Sys. Program] is selected, the Main Menu screen is displayed on completion of data transfer.
If data other than the above is selected, the following window is displayed on completion of data transfer.

The screenshot shows the 'Card Transfer' screen with a message box that says 'Work normally finished.' A hand icon is pointing at the 'OK' button.

Press the [OK] switch. The Card Transfer screen is displayed again. Return to the Main Menu screen using the [Return] switch.

Data transfer has been completed.

5.6 After Transfer (Communication with PLC) Connection with PLC

- To establish communication between MONITOUCH and a PLC, it is necessary to connect them using a communication cable.
When establishing 1:1 connection with a PLC, normally use the CN1 port (D-sub 9-pin) on MONITOUCH.

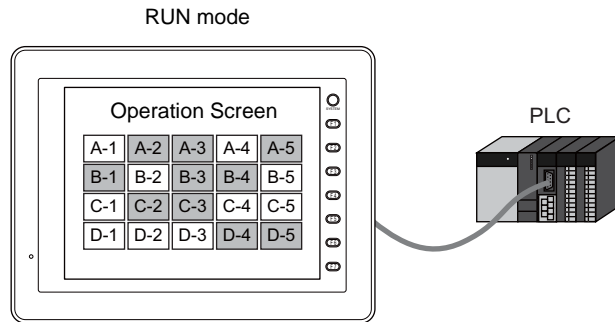

- For more information on wiring or the setting for connection, refer to the V8 Series Connection Manual.

Preparation for MONITOUCH

Switching to RUN (= Communicating) Mode

When the Main Menu screen is displayed during screen data transfer, it is necessary to restore the RUN state.

Press the [SYSTEM] function switch. When the menu is displayed, press the [F1] switch. Then, MONITOUCH is switched to the RUN state.

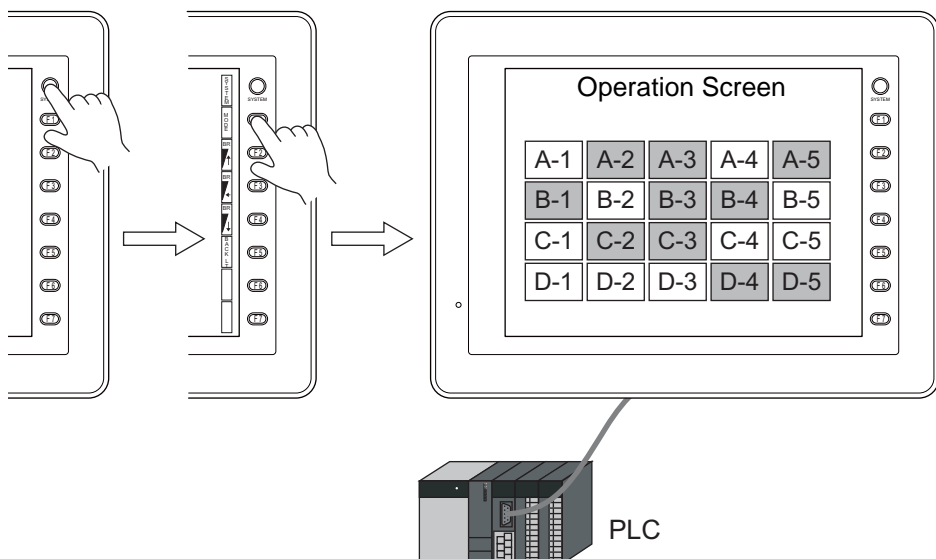

Display Contents after Communication

- When MONITOUCH starts communication with the PLC, it displays the screen specified in the read area address "n + 2".

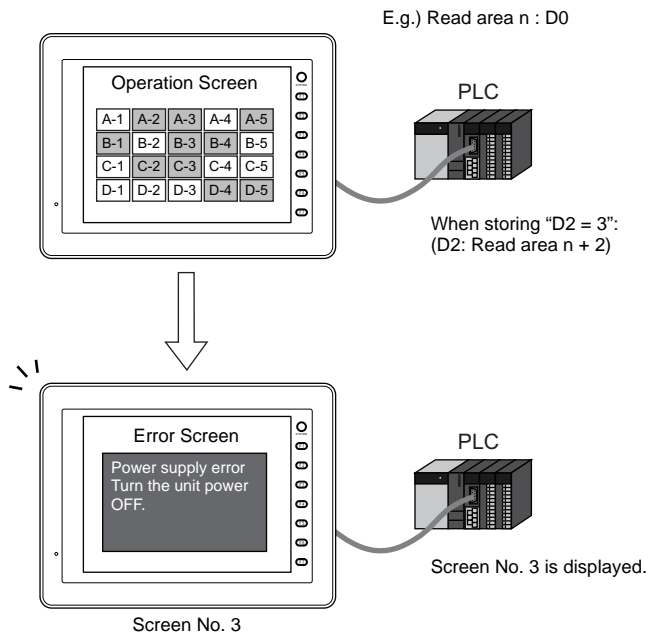

The value set in [Read Area] can be checked by selecting [Device Connection Setting] → [Read/Write Area] under [System Setting].
For more information, refer to "Chapter 1 System Setting" in the V8 Series Reference Manual.

- If a value not existing in the screen data file is set in [Read Area] "n + 2", the following error message is displayed.

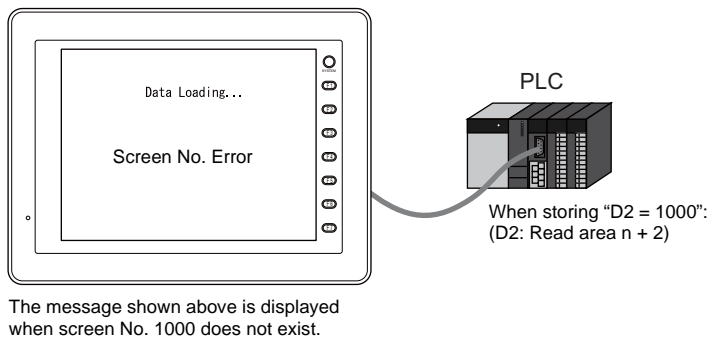

Check and correct the value in the read area address "n + 2".

6 Simulator

6.1 Overview

- When a MONITOUCH screen has been created, it is necessary to perform an operation check connecting the PLC to MONITOUCH. However, it is possible to perform an operation check on a newly created screen without the PLC using the Simulator. The Simulator runs on Windows, so you can set/reset bit access devices as well as input data to word access devices.

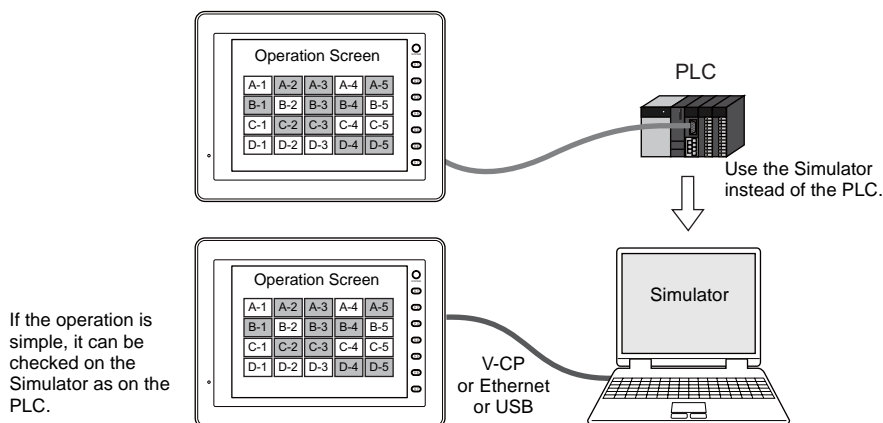

- Simulator is enabled only in connection format of 1:1 between the V8 unit and its connected device. Therefore, Simulator is disabled in connection formats of 1:n and n:1.**
- Simulator is also disabled where connection is established with a barcode reader or the V8 unit and its connected device are in slave communication (V-Link or MODBUS slave).**
- The V8 series unit can communicate with up to eight models of external device such as PLCs (= 8-way communication). Similarly, the same way, the Simulator can simulate up to eight models of external device. It is also possible, for example, to check only two out of eight models of device in simulation, and to actually connect to six real units.

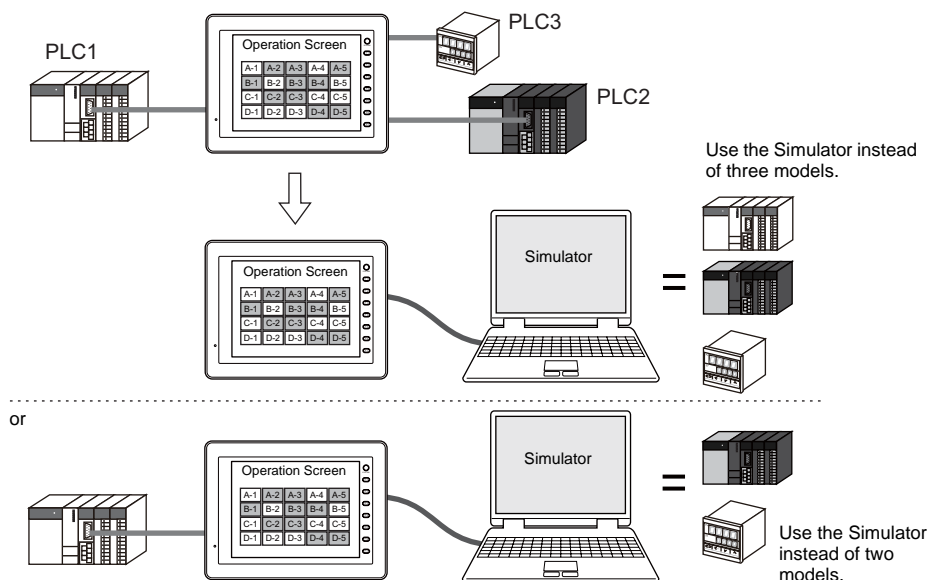

- As the Simulator works on the V-SFT editor (configuration software for the V series), the operation can be checked easily during editing. The operations of the parts placed on the screen can be checked in real time. Therefore, both screen creation and debugging become possible on one computer and time can be saved.

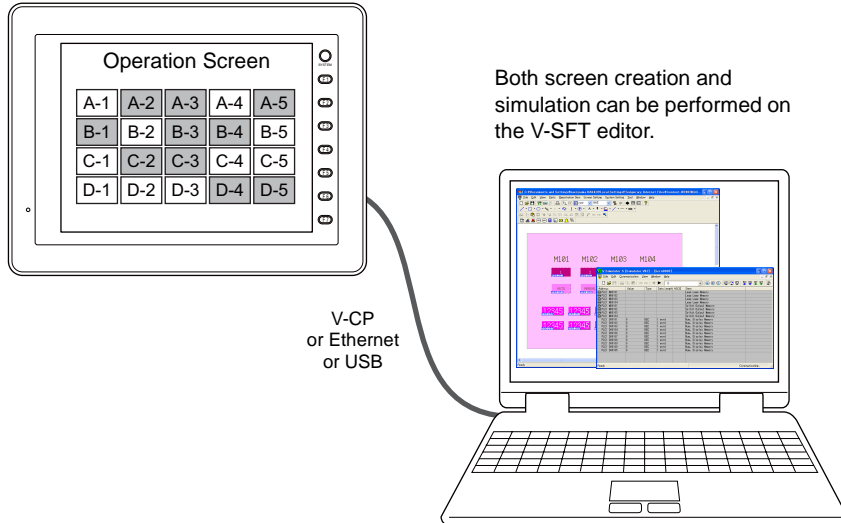

- A sheet for simulation is automatically created for each screen based on the memory used for V8 series screen data.

6.2 Operation Procedure

1. Open the screen data.
2. Connect the computer with the V8 series. (page 6-3)
3. Transfer the screen data to MONITOUCH.
 - Transfer of screen data and Simulator programs (page 6-5)
 - Simulator settings at the MONITOUCH side (page 6-6)
4. Start the Simulator → Start or stop communication
 - Start communication (page 6-12)
 - Stop communication (page 6-12)
5. Change the communication settings when needed.
 - How to change the communication settings (page 6-13)
6. Perform a test.
 - Testing bit access device (page 6-26)
 - Testing word access device (page 6-28)

6.3 Preliminaries

Connecting a Computer and the V8 Series

V-CP

Connect the V8 series to a computer using the data transfer cable (V-CP).

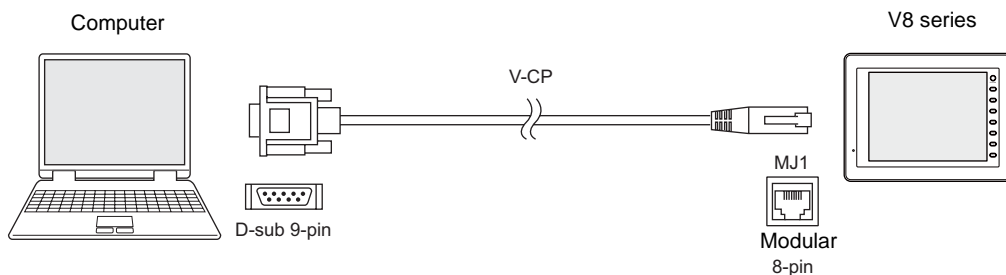

On the V8 series side, use MJ1 (modular jack 1).

In the editor, check that [No connection] is set for [MJ1].

- * Whether or not [No connection] is set for [MJ1] can be checked in the [Serial Port] tree structure displayed in the [Configuration] tab window of Project View (check [Project View] after selecting [View] → [View]).

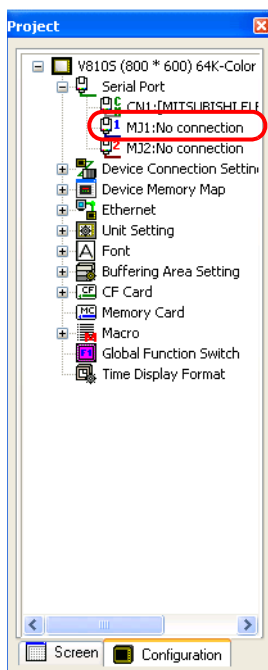

Ethernet

Connect the V8 series unit to the computer with a LAN cable.

Be sure to connect to the LAN port at the V8 series unit (note that this is possible only with the V8i: with models other than V8i the optional communication I/F unit is necessary).

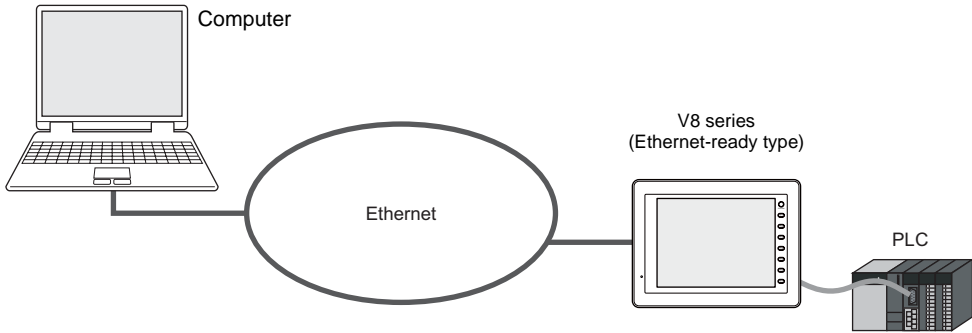

USB

Connect the V8 series unit to the computer with a USB cable.

Be sure to connect to the USB-B port at the V8 series unit.

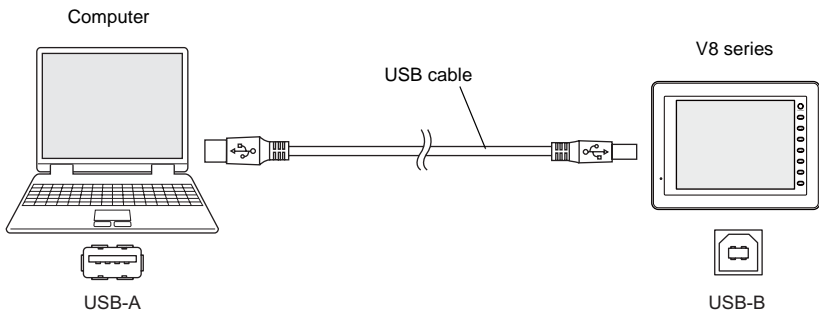

Transferring Screen Data and the Simulator Program

When transferring screen data, if you check the Use Simulator check box in the [Transfer] dialog, the Simulator program is automatically transferred together with the screen data.

 What is the Simulator program?

This is a driver file that is absolutely essential at MONITOUCH when using the Simulator. The driver files come in the following types.

File Name	Connection Format	Indication at MONITOUCH*
UniPLC_S.tpc	Serial (V-CP used)	MJ1 (Serial)
UniPLC_E.tpc	Ethernet	EtherNet (UDP)
UniPLC_U.tpc	USB	USB-B (Device)

* To check the indication at MONITOUCH, press the [Simulator] switch in the Main Menu drop-down window. For more information, see page 6-6.

When screen data is transferred, the driver file is automatically transferred too.

With V-CP (serial communication), "UniPLC_S.tpc" is automatically transferred; with Ethernet, "UniPLC_E.tpc" is automatically transferred, and if the data is transferred by USB, "UniPLC_U.tpc" is automatically transferred.

Transfer of Screen Data

Transfer data by following the procedure below.

1. Click [File] → [Transfer] or click the [Transfer] icon on the toolbar.
The [Transfer] dialog is displayed.

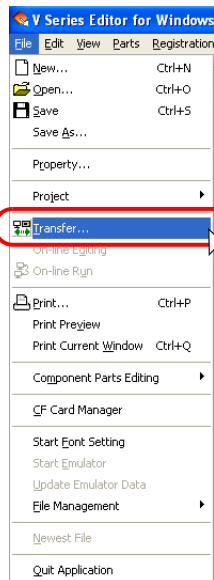

or

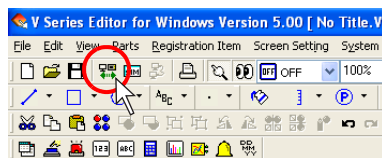

- The [Transfer] dialog is displayed.
Check Use Simulator.

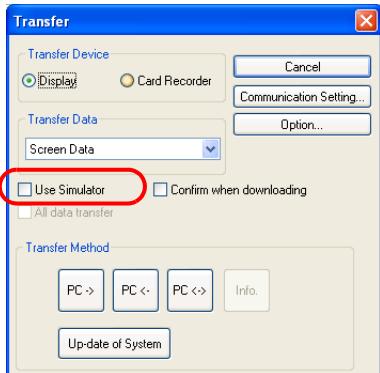

☺ For the other setting items ([Communication Setting], etc.), see “5.4 Transfer Procedure (Using a Communication Cable)” (page 5-10).

- Select [Screen Data] for [Transfer Data] and click the [PC ->] button.
The Simulator program is transferred together with the screen data.

☺ If you want to send the Simulator program by itself, select [Simulator Program] for [Transfer Data] and click the [PC->] button.
A dialog in which you can specify a file is displayed: select the relevant file and execute transfer.

Setting at MONITOUCH

When using the Simulator, be sure to make settings at MONITOUCH for using [Simulation] rather than [Real machine] (= each device). The procedure for this is as follows.

- After data transfer, press the [Main Menu] switch on the Main Menu screen at MONITOUCH, then press the [Simulator] switch.

☺ To display the Main Menu screen:
Press the [SYSTEM] switch. When the menu is displayed, press the [F1] switch. Then the Main Menu screen is displayed.

If the screen is not changed by pressing the [SYSTEM] or [F1] switch, the switch may be prohibited or set to become active when the switch is held down for a certain time.
For details, refer to the chapter on function switches in the V8 Series Hardware Specifications manual.

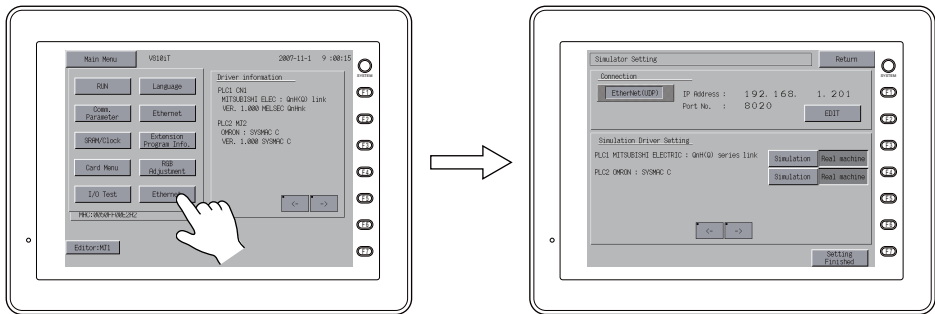

* If the [Simulator] switch doesn't appear on the screen, it is possible that the screen data has been transferred without the [Use Simulator] check box being checked, or that the transfer has not been completed correctly. Check and transfer the screen data again.

2. The Simulator Setting screen is displayed. Check if the setting under [Connection] agrees with the communication method used in the connection between the computer and MONITOUCH.

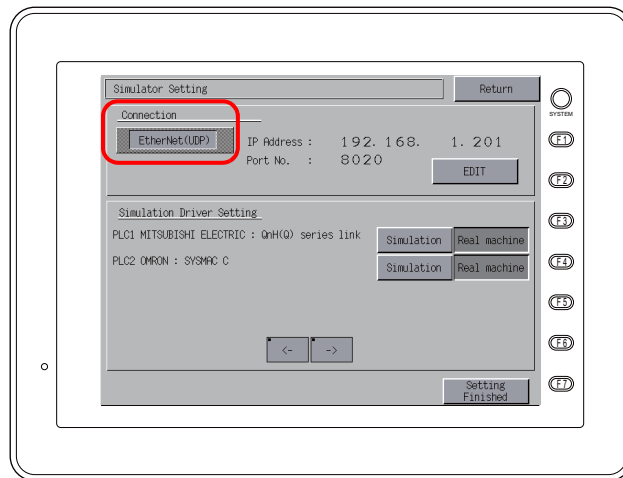

Indication	Meaning
MJ1 (Serial)	MJ1 at MONITOUCH is connected to the computer with V-CP to use the Simulator.
EtherNet (UDP)	The LAN port at MONITOUCH is connected to the computer with a LAN cable to use the Simulator.
USB-B (Device)	The USB-B port at MONITOUCH is connected to the computer with a USB cable to use the Simulator.

- If the setting under [Connection] is [EtherNet (UDP)], settings should also be made for [IP Address] and [Port No.].
If the setting under [Connection] is [MJ1 (Serial)] or [USB-B (Device)], proceed to step 4.

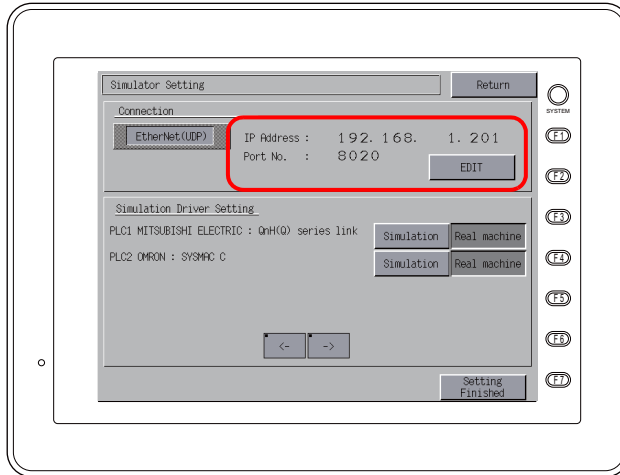

IP Address	Set the IP address of the computer that is the connection destination here. Press the [EDIT] switch on the right to display a numeric keypad, and use this to enter the address. The default setting (at the time of purchase) is "192.168.1.201".
Port No.	Set the port No. for the Simulator here. Press the [EDIT] switch on the right to display a numeric keypad, and use this to enter the address. Set the same number as the one set for [Port No.] in the Simulator window ([File] → [Communication Setting]). The default is "8020".

- Next, under [Simulation Driver Setting], set the devices whose communications the Simulator is to simulate.
The names of the devices allocated to each "way" are displayed, and to the right of each of them there are a [Simulation] switch and a [Real machine] switch. Press the [Simulation] switches of those devices that are to be simulated by the Simulator.

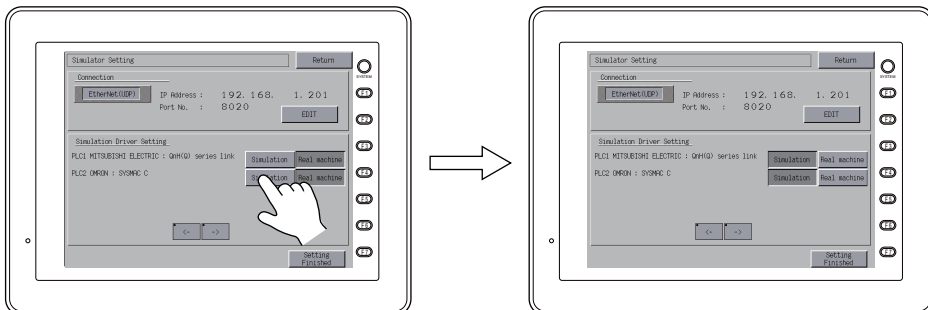

For example, if the Simulator is to be used for both PLC1 and PLC2, press the [Simulation] switches at both these device names.

☺ Where the Simulator is not to be used, click the [Real machine] switch.
There is no need to resend the screen data.

5. Press the [Setting Finished] switch. The Main Menu screen is displayed again.

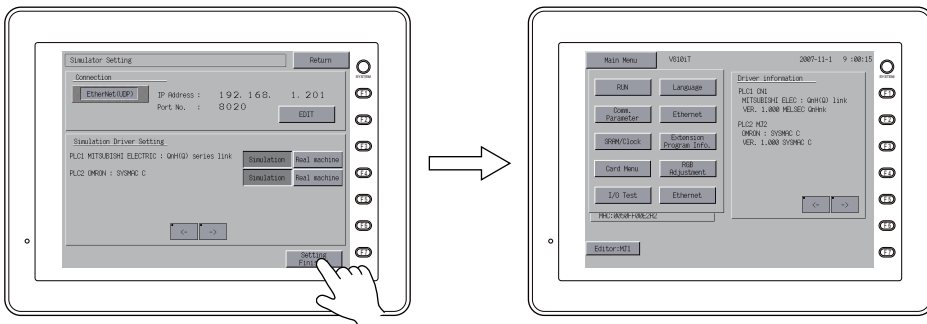

To check the version of the Simulator program:

Press the [Extension Program Info.] switch in the Main Menu drop-down window.

The Extension Program Info. screen is displayed.

On this screen you can check the version of the Simulator program and the type of the program (SERIAL / ETHERNET / USB).

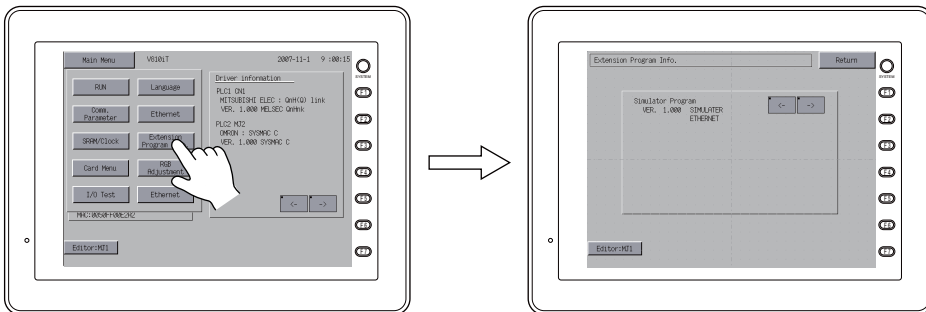

6.4 Starting and Ending

Starting

1. Click [View] → [View] → [Simulate] or click the [Simulate] icon on the toolbar.

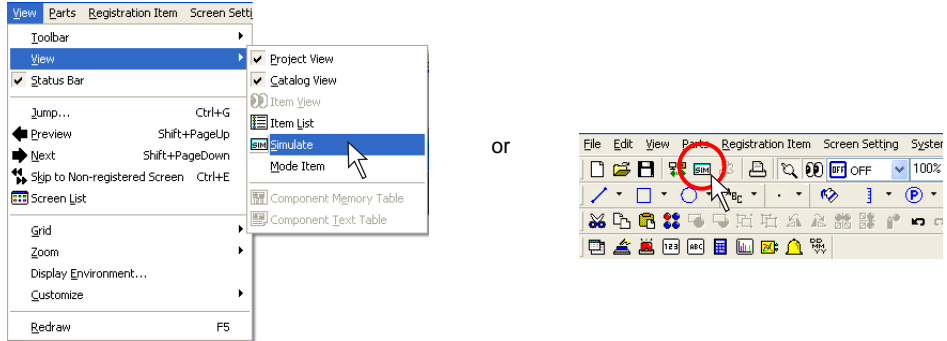

2. The Simulator starts up.
Communication with MONITOUCH starts at this time.
Addresses related to the screen data currently opened on the editor are automatically displayed on the [Simulator] window.

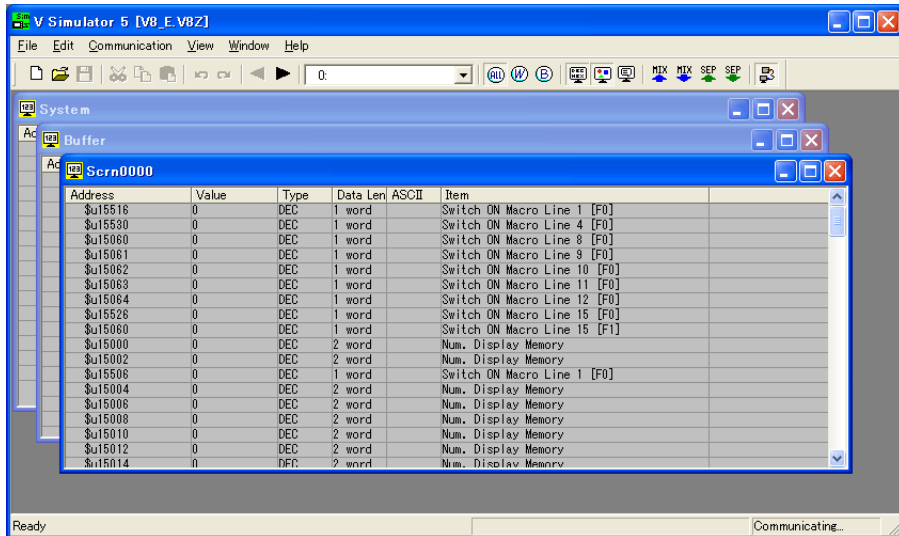

If the Main Menu screen is displayed on the V8 series, switch it to the RUN screen by pressing the [SYSTEM] switch and then the [F1] switch or pressing the [Main Menu] switch and then the [RUN] switch.
The Simulator starts communication with MONITOUCH.

Ending

1. Either click [Exit] in the [File] menu in the [Simulator] window, or click the [Close] button, or click [View] → [View] → [Simulate] on the editor to cancel the depressed status of the icon.

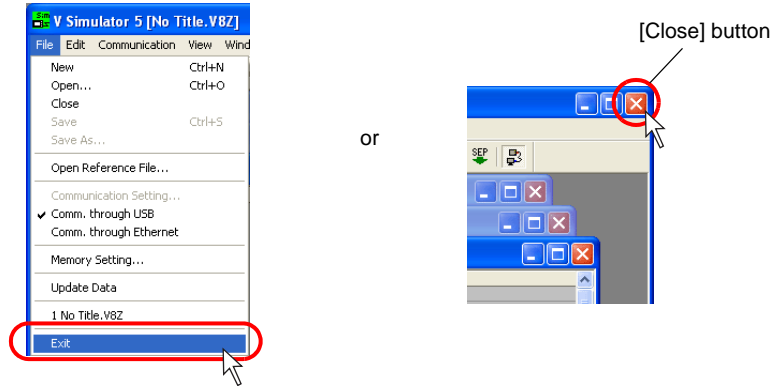

OR

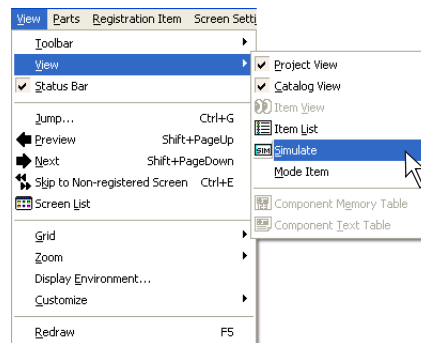

2. The [Simulator] window is closed.
At the same time, communications with MONITOUCH are canceled, and “SIM Communication Error Simulator Not Connected” is displayed at MONITOUCH.

6.5 Start and Stop Communication

Starting Communication

Communication using the Simulator is started when the [Simulator] window is opened.

The communication status is shown on the [Communication] icon or on the status display at the bottom of the window.

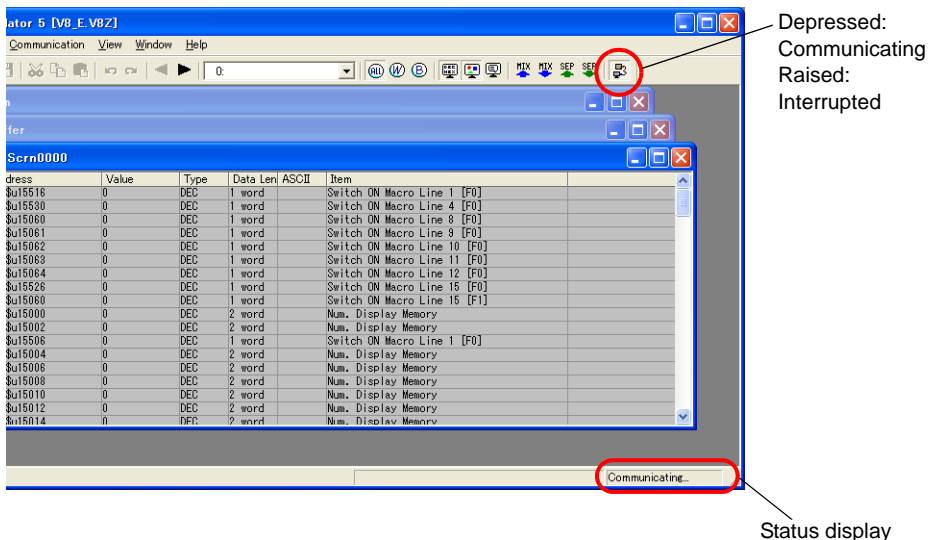

Stopping Communication

Click the [Communication] icon and make it raised (communication stopped).

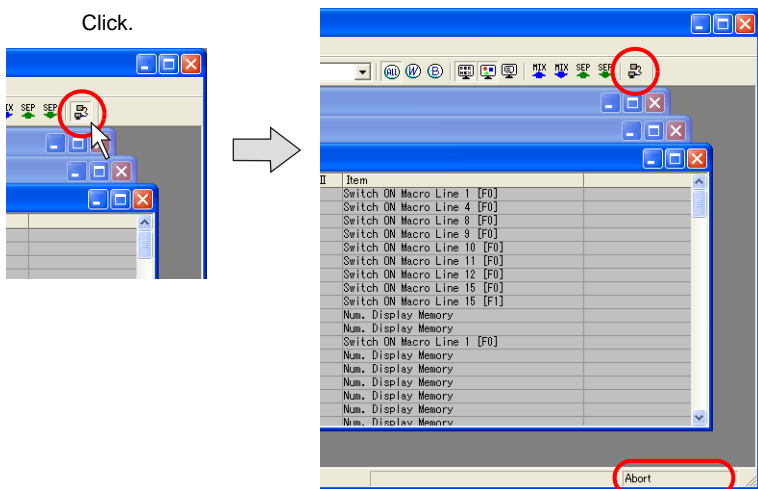

☺ "SIM Communication Error Simulator Not Connected" is displayed at the top left of the MONITOUCH screen.

Communication Setting

Make the required settings for communication between the computer and the V8 series.
If the settings are faulty, the V8 series and computer will not communicate correctly.
In such an event, be sure to check the settings.

- * Before checking the communication setting, stop the communication between devices.

Serial Communication

1. Click [File] in the [Simulator] window.
After checking that both [Comm. through USB] and [Comm. through Ethernet] are unchecked, click [Communication Setting].

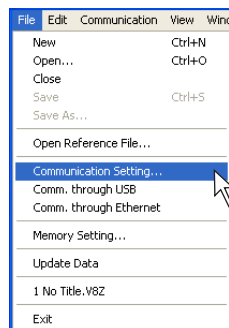

2. The [Communication Setting] dialog is displayed.

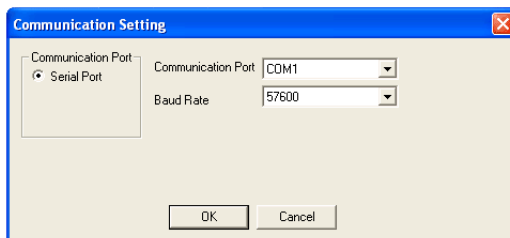

Communication Port	Only [Serial Port] can be selected.
Communication Port	Set the RS-232C COM port number for the computer.
Baud Rate	Set the baud rate for communication between the computer and V8 series. (This has no relation to the actual communication baud rate between the V8 series and the PLC.)

Ethernet

1. Click [File] in the [Simulator] window.
Check that [Comm. through Ethernet] is checked, then click [Communication Setting].

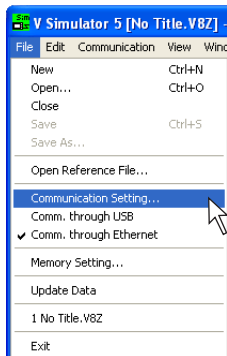

2. The [Port No.] dialog is displayed.

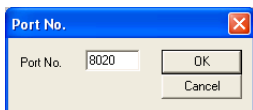

Port No.	The default setting is "8020". Set this port number at MONITOUCH as well.
----------	--

USB

- Click [File] in the [Simulator] window.
Check that [Comm. through USB] is checked. This completes the setting.

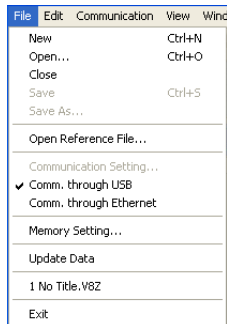

6.6 Configuration of Simulator

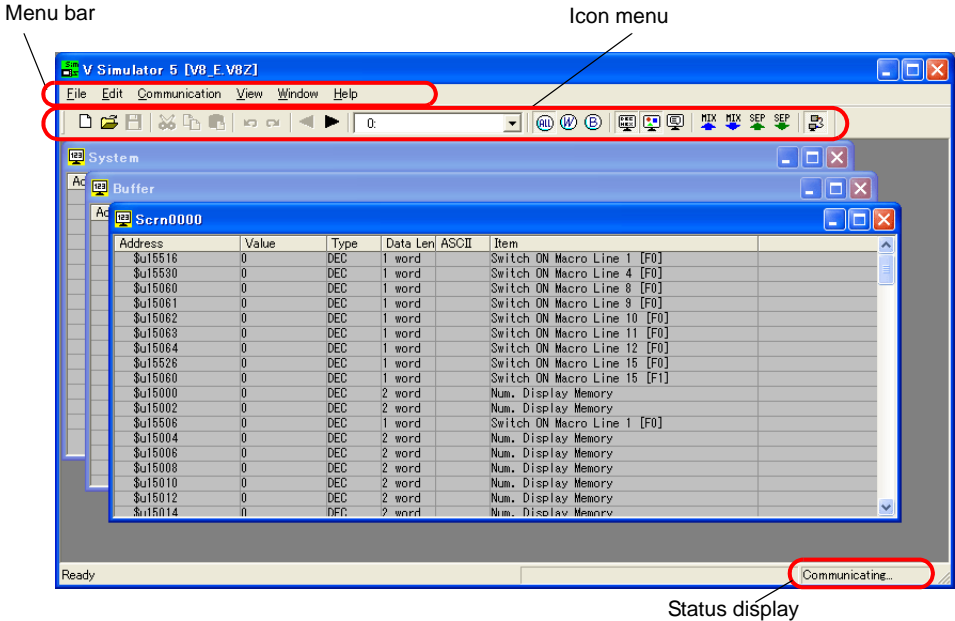

Menu bar		For more information, see page 6-16.
Icon menu		For more information, see page 6-19.
Individual sheets	System	Displays a list of addresses used for system settings of the screen data file.
	Scrn xxxx	Displays a list of addresses used on each screen.
	Buffer	Displayed if memory has been set in buffering area setting. The addresses used in each buffer are displayed.
	Mlib xxxx	Displayed when a multi-overlap or call overlap is displayed. Addresses used on each overlap library are listed.
	Untitled	Displays addresses newly registered. For more information on registering a new address, see page 6-23.
Status display		Displays the current Simulator status (Communicating or Stopped).

Menu Bar

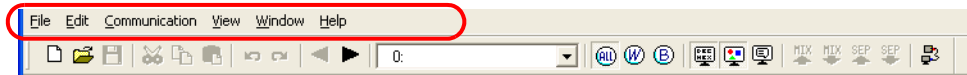

<p>File</p>	New	Creates a new [Untitled] sheet.
	Open	Opens existing screen data files (*.V8" etc.) and memory table files (*.sim" etc).
	Close	Closes the open sheet.
	Save	Saves the open sheet.
	Save As	Saves the open sheet under a different name.
	Open Reference File	Opens the Simulator's reference screen data file (*.V8" etc.).
	Communication Setting	Set for serial or Ethernet communications. For more information, see page 6-13.
	Comm. through USB	Automatically checked when data is to be communicated through USB.
	Comm. through Ethernet	Automatically checked when data is to be communicated through Ethernet.
	Memory Setting	Sets the memory range to be used by the Simulator.
	Update Data	When the reference source screen data file has changed, clicking here updates the screen with the most recent data.
	Exit	Terminates the Simulator.

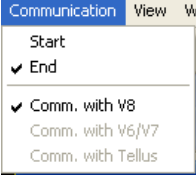
<p>Edit</p> 	<p>Add Item</p>	<p>This is a setting that is effective on [Untitled] sheets. It adds a new address.</p>
	<p>Delete Item</p>	<p>This is a setting that is effective on [Untitled] sheets. It deletes an address.</p>
	<p>Delete Items (All)</p>	<p>This is a setting that is effective on [Untitled] sheets. It deletes all addresses.</p>
	<p>Undo</p>	<p>Cancels actions performed.</p>
	<p>Redo</p>	<p>Reverts to the state prior to undo.</p>
	<p>Cut</p>	<p>This is a setting that is effective on [Untitled] sheets. It cuts an address.</p>
	<p>Copy</p>	<p>Copies selected address.</p>
	<p>Paste</p>	<p>This is a setting that is effective on [Untitled] sheets. It pastes copied or cut address.</p>
	<p>Select All</p>	<p>Selects all the addresses on the sheet.</p>
	<p>Change Display Address</p>	<p>This is a setting that is effective on [Untitled] sheets. It changes the selected address to a different address.</p>
	<p>Change Setting Value</p>	<p>Changes the value of the selected address.</p>
	<p>Display Type Setting</p>	<p>Changes the display type of the selected address.</p>
	<p>Item Setting</p>	<p>This is a setting that is effective on [Untitled] sheets. It is used to set the item, etc. for the selected address.</p>
	<p>Comment Setting</p>	<p>This is a setting that is effective on [Untitled] sheets. It is used to set a comment for the selected address.</p>
	<p>Sort Memory</p>	<p>Used to set the memory display method.</p>
<p>Communication</p> 	<p>Start</p>	<p>Starts communication.</p>
	<p>End</p>	<p>Ends communication.</p>
	<p>Comm. with V8</p>	<p>Automatically checked when communicating with a V8 series unit.</p>
	<p>Comm. with V6/V7</p>	<p>Automatically checked when communicating with a V7 or V6 series unit.</p>
	<p>Comm. with Tellus</p>	<p>Automatically checked when communicating with Tellus.</p>

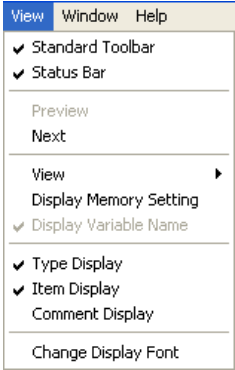
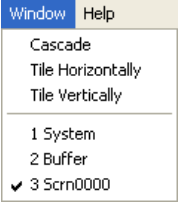
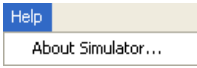
<p>View</p> 	Standard Toolbar	The toolbar is displayed when this option is checked.
	Status Bar	The status bar is displayed when this option is checked.
	Preview	This is a setting that is effective on [Scrn xxxx] sheets. It displays a previous screen.
	Next	This is a setting that is effective on [Scrn xxxx] sheets. It moves to the next screen.
	View	Selects the memory to be viewed.
	Display Memory Setting	Used to set which PLC addresses of PLC1 to PLC8 are to be displayed.
	Type Display	Displays [Type] / [Data Length] / [ASCII].
	Item Display	Displays an item.
	Comment Display	Displays a comment.
	Change Display Font	Used to set the font size, etc, to be displayed on the sheet.
	<p>Window</p> 	Cascade
Tile Vertically		Displays sheets arranged vertically on the screen.
Tile Horizontally		Displays sheets arranged horizontally on the screen.
<p>Help</p> 	About Simulator	Displays the version information for the Simulator.

Icon Menu

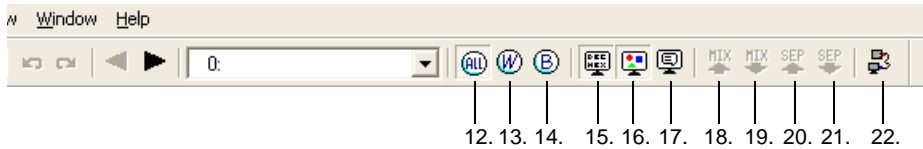
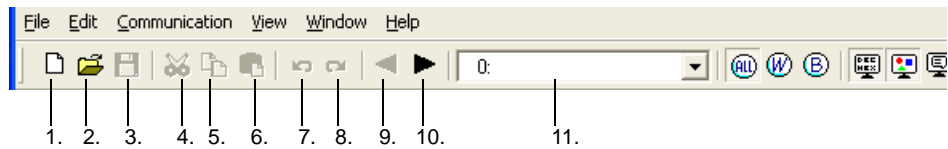

1. New	Opens a new sheet [Untitled]. With this sheet, you can register and check addresses that do not exist on the [System] or [Scrn xxxx] sheet automatically created. (Refer to page 6-23.)
2. Open	Opens an already stored sheet.
3. Save	Saves an [Untitled] sheet under a new name.
4. Cut	This is a setting that is effective on [Untitled] sheets. Cuts selected address.
5. Copy	Copies selected address.
6. Paste	This is a setting that is effective on [Untitled] sheets. Pastes copied or cut address.
7. Undo	Cancels actions performed.
8. Redo	Reverts to the state prior to undo.
9. Previous Screen	This is a setting that is effective on [Screen] sheets. Displays the previous screen.
10. Next Screen	This is a setting that is effective on [Screen] sheets. Moves to the next screen.
11. Active Screen	Displays the selected screen numbers.
12. Display All	Displays all word items and bit items.
13. Word	Displays word item.
14. Bit	Displays bit item.
15. Format Display	Displays [Type] / [Data Length] / [ASCII].
16. Item Display	Displays an item.
17. Comment Display	Displays a comment.
18. Mix Sort (numerical)	Sorts the memory.
19. Mix Sort (reverse)	
20. Separate Sort (numerical)	
21. Separate Sort (reverse)	
22. Communication	Starts or stops communication. For more information, see page 6-12.

Configuration within a Sheet

This example includes the format display, item display, and comment display.

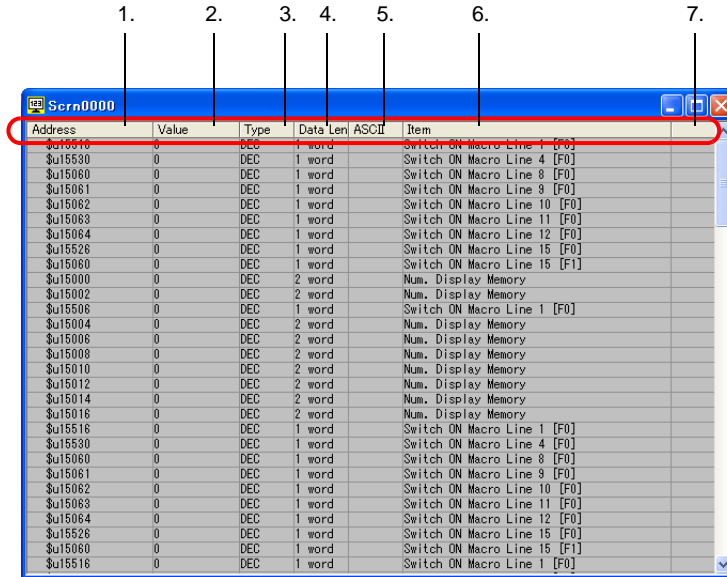

1. Address	Shows addresses.
2. Value	Shows setting values currently entered.
3. Type	Shows display formats currently set.
4. Data Length	Shows data length currently set.
5. ASCII	This item is valid only when [Display] is selected for [ASCII]. Shows current setting values in ASCII code format.
6. Item	Shows item names and setting items for addresses.
7. Comment	This setting is valid for the display registered on an [Untitled] sheet. Shows comments registered on the [Untitled] sheet.

How to Change the Value (Word Address)

- 1. Double-click the [Value] field, or right-click the mouse and click [Change Setting Value].

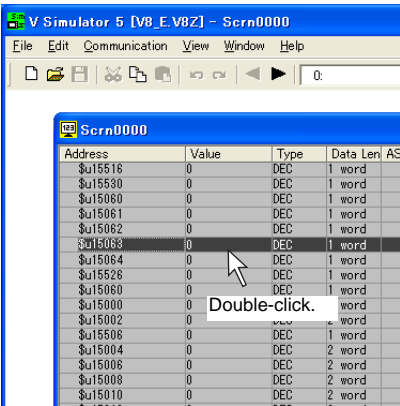

OR

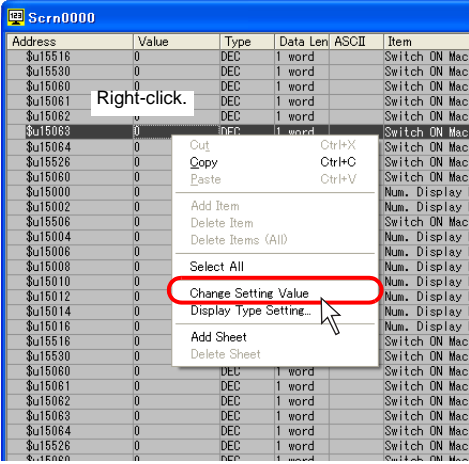

- 2. The [Write Memory] dialog opens. Set the desired value and click [OK].

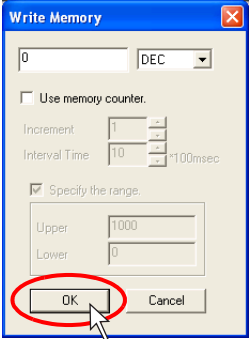



Memory counter

Checking Use memory counter.] makes it possible to increment or decrement values within the specified range.

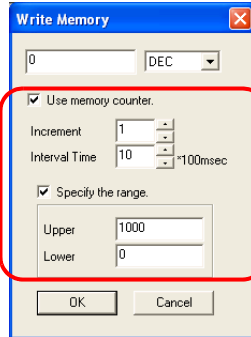

When this box is checked, the “□” mark is displayed on the left of the address displayed on the window.
Clicking the mark executes increment or decrement.

Address	Value	Type	Data Len	ASCII	Item
\$u15516	0	DEC	1 word		Switch ON Macro Line 1 [F0]
\$u15530	0	DEC	1 word		Switch ON Macro Line 4 [F0]
\$u15080	0	DEC	1 word		Switch ON Macro Line 8 [F0]
\$u15081	0	DEC	1 word		Switch ON Macro Line 9 [F0]
\$u15082	0	DEC	1 word		Switch ON Macro Line 10 [F0]
\$u15083	0	DEC	1 word		Switch ON Macro Line 11 [F0]
\$u15084	0	DEC	1 word		Switch ON Macro Line 12 [F0]
\$u15526	0	DEC	1 word		Switch ON Macro Line 15 [F0]
\$u15080	0	DEC	1 word		Switch ON Macro Line 15 [F1]
\$u15000	0	DEC	2 word		Num. Display Memory
\$u15002	0	DEC	2 word		Num. Display Memory
\$u15006	0	DEC	1 word		Switch ON Macro Line 1 [F0]
\$u15004	0	DEC	2 word		Num. Display Memory
\$u15006	0	DEC	2 word		Num. Display Memory
\$u15008	0	DEC	2 word		Num. Display Memory
\$u15010	0	DEC	2 word		Num. Display Memory
\$u15012	0	DEC	2 word		Num. Display Memory
\$u15014	0	DEC	2 word		Num. Display Memory
\$u15016	0	DEC	2 word		Num. Display Memory
\$u15516	0	DEC	1 word		Switch ON Macro Line 1 [F0]
\$u15530	0	DEC	1 word		Switch ON Macro Line 4 [F0]
\$u15080	0	DEC	1 word		Switch ON Macro Line 8 [F0]
\$u15081	0	DEC	1 word		Switch ON Macro Line 9 [F0]
\$u15082	0	DEC	1 word		Switch ON Macro Line 10 [F0]
\$u15083	0	DEC	1 word		Switch ON Macro Line 11 [F0]
\$u15084	0	DEC	1 word		Switch ON Macro Line 12 [F0]
\$u15526	0	DEC	1 word		Switch ON Macro Line 15 [F0]
\$u15080	0	DEC	1 word		Switch ON Macro Line 15 [F1]

3. The value input on the sheet is displayed. Values input at MONITOUCH are recognized too.

[Untitled] Sheet

Adding a new address

To check the address that is not shown on the [System] or [Screen] sheet, it is necessary to create a new [Untitled] sheet and to add or to insert the address on the sheet.

The procedure for adding a new address is described below.

- 1. Create a new sheet.
Click [File] → [New] or click the [New] icon on the toolbar.

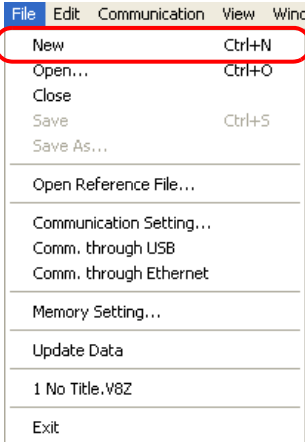

or



- 2. A new [Untitled] sheet is displayed.

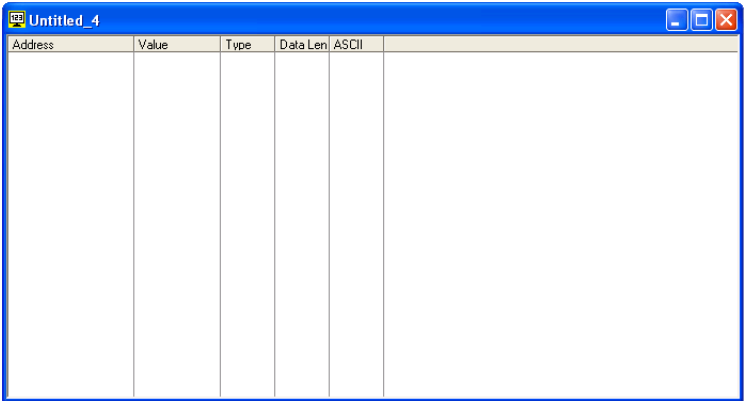

- Right-click the mouse and click [Add Item].
The [Add Memory] dialog opens.

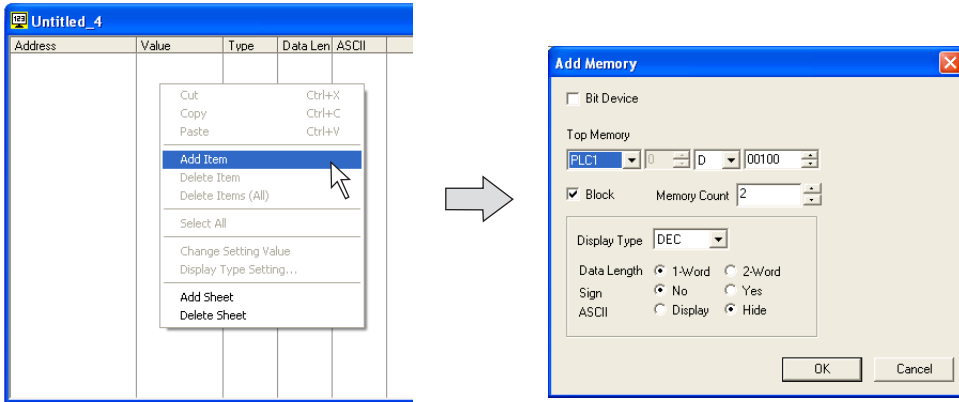

- For the bit access device, check [Bit Device].
Make the desired settings and click [OK].
The set address is displayed on the sheet.

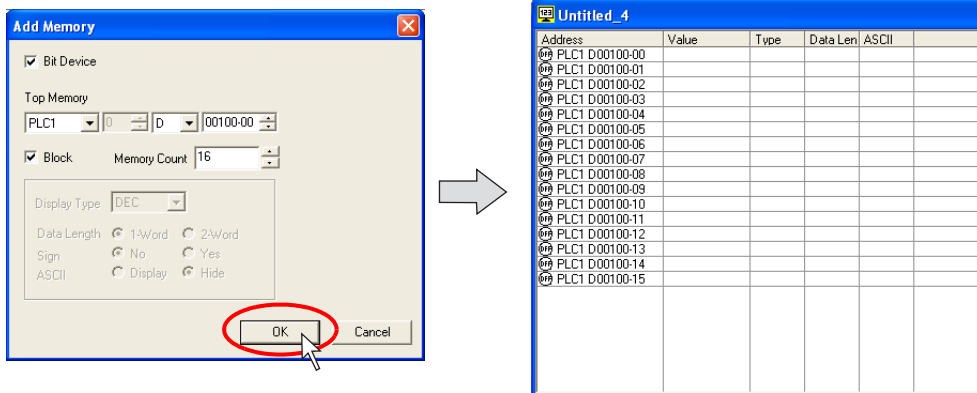

Display Memory

- With a V8 series unit, the Simulator function can be used for communication in a maximum of eight channels (8 ways).
Set whether the Simulator is to be used or not for each device.
Where addresses of devices that don't use the Simulator have been displayed in the Simulator window, these addresses are displayed in red as shown below, while changes to values that have been made in the Simulator are not reflected.

Address	Value	Type	Data Len	ASCII	Item
PLC1 D00100	0	DEC	1 word		Num. Display Memory
PLC2 DM00100	0	DEC	1 word		Num. Display Memory
PLC2 DM00101	0	DEC	1 word		Num. Display Memory
PLC2 DM00102	0	DEC	1 word		Num. Display Memory
PLC2 DM00103	0	DEC	1 word		Num. Display Memory
PLC2 DM00104	0	DEC	1 word		Num. Display Memory
PLC2 DM00105	0	DEC	1 word		Num. Display Memory
PLC2 DM00106	0	DEC	1 word		Num. Display Memory
PLC2 DM00107	0	DEC	1 word		Num. Display Memory
PLC2 DM00108	0	DEC	1 word		Num. Display Memory
PLC2 DM00109	0	DEC	1 word		Num. Display Memory
PLC1 D00101	0	DEC	1 word		Num. Display Memory
PLC1 D00102	0	DEC	1 word		Num. Display Memory
PLC1 D00103	0	DEC	1 word		Num. Display Memory
PLC1 D00104	0	DEC	1 word		Num. Display Memory
PLC1 D00105	0	DEC	1 word		Num. Display Memory
PLC1 D00106	0	DEC	1 word		Num. Display Memory
PLC1 D00107	0	DEC	1 word		Num. Display Memory
PLC1 D00108	0	DEC	1 word		Num. Display Memory
PLC1 D00109	0	DEC	1 word		Num. Display Memory
PLC1 M00000					Lamp Lamp Memory
PLC1 M00001					Lamp Lamp Memory
PLC1 M00002					Lamp Lamp Memory
PLC1 M00003					Lamp Lamp Memory
PLC1 M00004					Lamp Lamp Memory

- When displaying memory contents, you can select which addresses of PLC1 to PLC8 are to be displayed.
Click [View] → [Display Memory Setting].
The [Display Memory Setting] dialog is displayed.

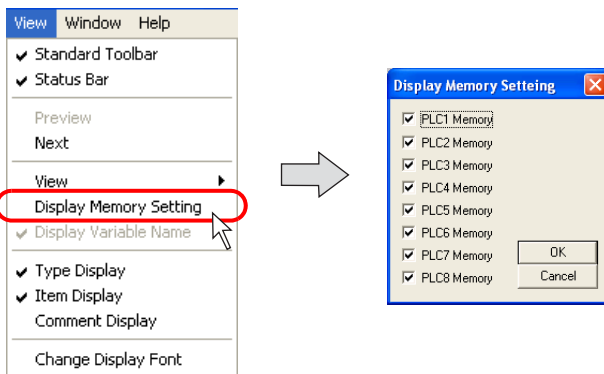

Check the PLC(s) whose information is to be displayed and click [OK]. Only the addresses of the selected devices are displayed in the Simulator window.

6.7 Test Example

As an example, the procedure to perform a test using the screen shown below is described.

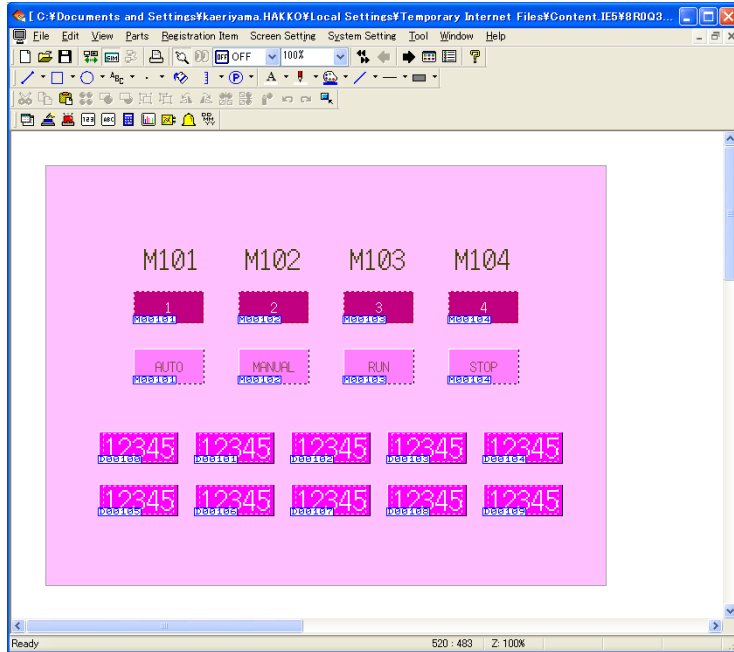

Testing Bit Access Device

V8 Series → Simulator

Use the Simulator to check the output signal. As an example, “M101” is set as an output memory on the [AUTO] switch on the extreme left side.

1. Press the [AUTO] switch on the extreme left of the MONITOUCH screen.

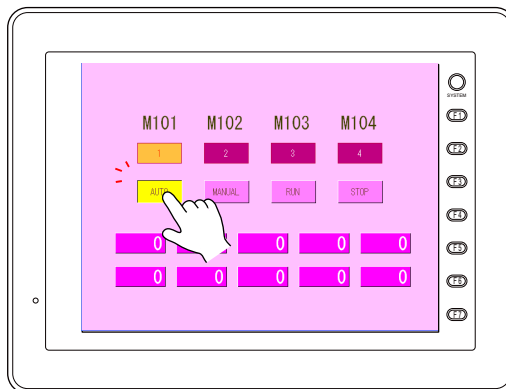

- “M0101” displayed on the Simulator is turned ON. The icon on the left will change from [OFF] to [ON].

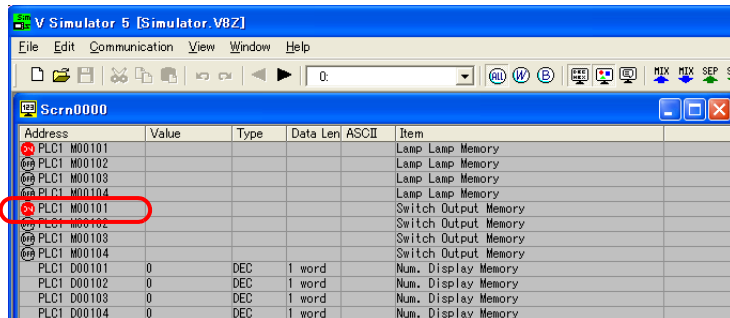

Simulator → V8 Series

Use the Simulator to turn the lamp on. As an example, “M104” is set for lamp “4” on the extreme right side.

- On the Simulator, click the [OFF] icon for “M104” (lamp memory). The icon will be changed from [OFF] to [ON].

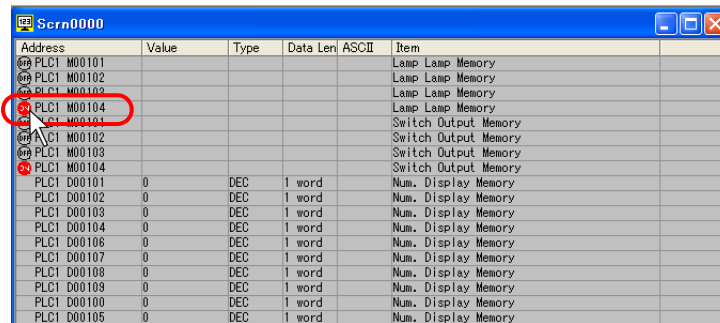

- Lamp “4” will light up on MONITOUCH.

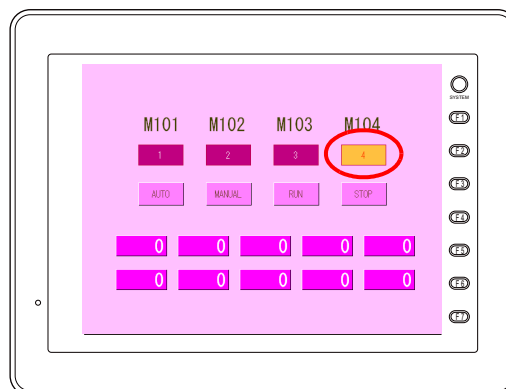

When pressing the space key with the memory selected by cursor, the bit access device can be set/reset.
To reverse multiple bits simultaneously, see page 6-29.

Testing Word Access Device

This section describes the procedure to change the numerical value of the data display. For example, the value “D100” will be changed.

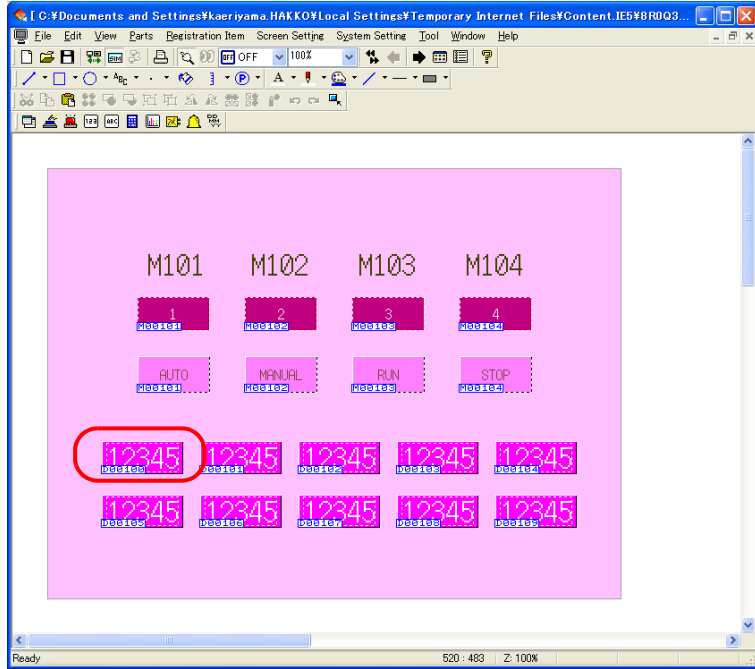

1. Double-click the field “D100” on the Simulator.

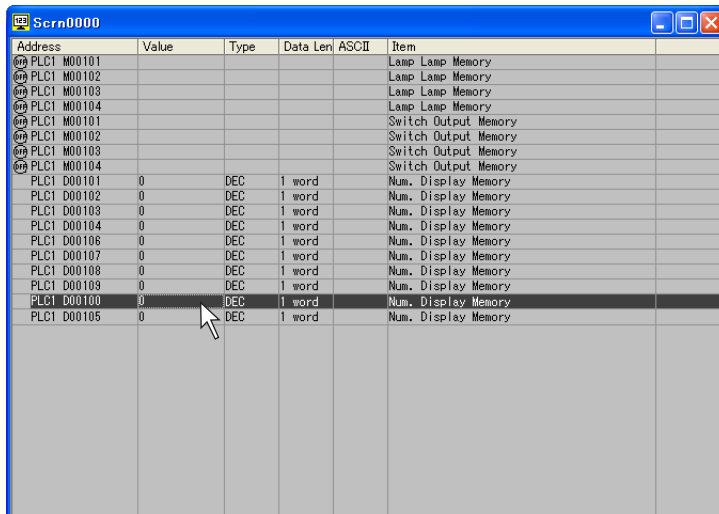

2. The [Write Memory] dialog is displayed.

- Key in a value as desired. (If necessary, change the format of the value that you enter.)
As an example, "123" is entered in decimal notation.

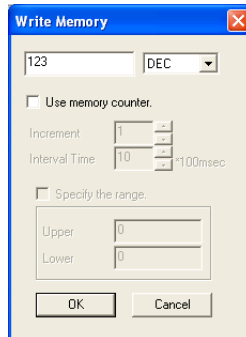

- Click [OK] to close the dialog.
- "123" is displayed on MONITOUCH.

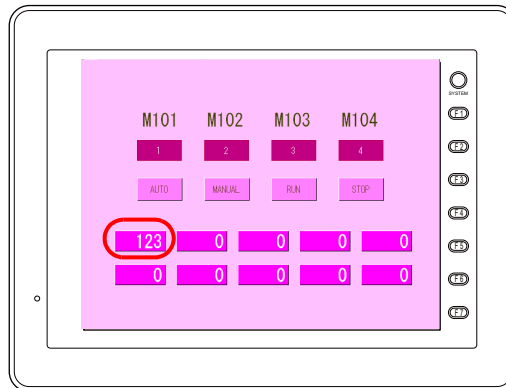

Setting/resetting multiple bits simultaneously

- Select the bit access device that will be set/reset (multiple selections possible).
You can sequentially select multiple bits by holding down the [SHIFT] key and clicking the mouse.
You can randomly select bits by holding down the [CTRL] key and clicking the mouse.
- Pressing the space key sets the bits.
- Pressing the space key again resets the bits.



Entering numerical values for multiple pieces of memory simultaneously

- Select the memory for which you will set numerical values (multiple selections possible).
You can sequentially select multiple bits by holding down the [SHIFT] key and clicking the mouse.
You can randomly select bits by holding down the [CTRL] key and clicking the mouse.
- Right-click on any of the lines that are selected, and then click [Change Setting Value].
- Set the desired number and click [OK]. The numbers of all the selected lines will be changed simultaneously.

6.8 Error List

During communication between the Simulator (= computer) and V8 series unit, the following errors may occur at the V8 series unit. The details of the errors are as described below.

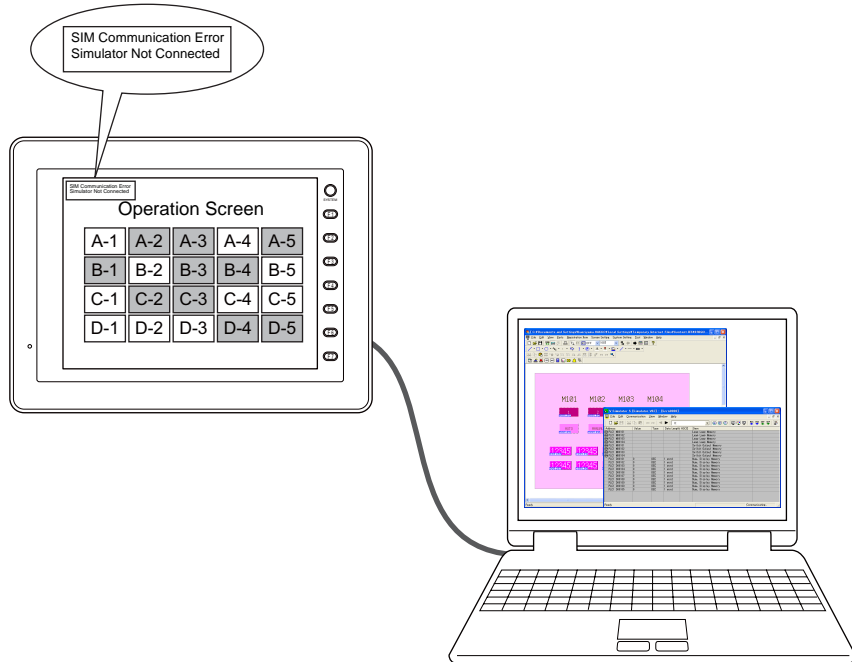

Message	Contents	Measures
SIM Communication Error Simulator Not Connected	When a communication request is sent to a computer (Simulator), there is no reply from the computer.	If the error is not recovered after checking the items shown below, re-start the Simulator.
		Serial communication <ul style="list-style-type: none"> • Wiring Connect a V-CP cable to the MJ1. • Simulator setting Check the baud rate setting and the COM port setting in the [Communication Setting] dialog ([File] → [Communication Setting]).
		Ethernet communication <ul style="list-style-type: none"> • Wiring Continuity of the LAN cable Connect a LAN cable to the LAN port. • Simulator setting Check that [Comm. through Ethernet] in the [File] menu is checked. Check [Port No.] in the [Communication Setting] dialog ([File] → [Communication Setting]). (Match the number to the one set on the V8 series.) • V8 series setting At [Connection] on the Simulator Setting screen; <ul style="list-style-type: none"> - Specify the same IP address as the one set on the computer. - Specify the same port No. as the one set on the Simulator.
		USB communication <ul style="list-style-type: none"> • Wiring Connect a USB cable to the USB-B port. • Simulator setting Check that [Comm. through USB] in the [File] menu is checked.

Message	Contents	Measures
SIM Communication Error Simulator Not Connected	The Simulator has been exited. Or communication is suspended.	Check the Simulator. <ul style="list-style-type: none">• Check that [Start] in the [Communication] menu is checked.• Check the address range on the [Memory Setting] dialog ([File] → [Memory Setting]).
SIM Communication Error Ethernet Error xxx(x)	Communication error during Ethernet communications.	Check whether an error relating to Ethernet communications, such as "link down" (801), has occurred, and check the cable, IP address, etc.
SIM Communication Error Format	Format error (characters in nonconforming formats)	A communication error arises between the V8 series and the computer. Check if there are any adverse effects due to noise, etc.

MEMO



Please use this page freely.

Hakko Electronics Co., Ltd.
www.monitouch.com

Sales 890-1, Kamikashiwano-machi, Hakusan-shi,
Ishikawa, 924-0035 Japan
TEL +81-76-274-2144 FAX +81-76-274-5136