

Content

1 Safety Precautions	1
1.1 Safety definition	1
1.2 Warning symbols	1
1.3 Safety guidelines	1
2 Inspection	4
2.1 Unpacking inspection	4
2.2 Application confirmation	4
2.3 Installation confirmation	4
3 Product overview	6
3.1 Comprehensive features	6
3.2 Product name and model	6
3.3 Rated specifications	7
4 Installation Guidelines	9
4.1 Installation environment	9
4.2 Installation direction	10
4.3 Installation steps	11
4.4 Terminals and function	12
4.5 Standard wiring	14
4.6 Parallel connection	15
5 Keypad Operation	18
5.1 Keypad	18
6 Function parameters	20
6.1 Function code	20
6.2 Detailed function	23
7 Fault tracking	25
8 Maintenance and hardware diagnostics	27
8.1 Maintenance interval	27
8.2 Cooling fan	29
8.3 Capacitors	29
8.4 Power cables	31
9 Dimension and size	32
9.1 Dimension of the keypad	32
9.2 External dimension of RBU	33





1 Safety Precautions

1.1 Safety definition



Danger:	Serious physical injury or even death may occur if not follow relevant requirements
Warning:	Physical injury or damage to the devices may occur if not follow relevant requirements
Note:	Physical hurt may occur if not follow relevant requirements
Qualified electricians:	People working on the device should take part in professional electrical and safety training, receive the certification and be familiar with all steps and requirements of installing, commissioning, operating and maintaining the device to avoid any emergency.

1.2 Warning symbols

Warnings caution you about conditions which can result in serious injury or death, damage to the equipment and advice on how to avoid the danger. Following warning symbols are used in this manual:

Symbols	Name	Instruction	Abbreviation
 Danger	Danger	Serious physical injury or even death may occur if not follow the relative requirements	
 Warning	Warning	Physical injury or damage to the devices may occur if not follow the relative requirements	
Note	Note	Physical hurt may occur if not follow the relative requirements	Note

1.3 Safety guidelines

	<ul style="list-style-type: none"> ✧ Only qualified electricians are allowed to operate. ✧ Do not carry out any wiring and inspection or changing components when the power supply is applied.
	<ul style="list-style-type: none"> ✧ Do not refit unauthorizedly; otherwise fire, electric shock or other injury may occur.

1.3.1 Delivery and installation

	<ul style="list-style-type: none"> ✧ Please install the RBU on fire-retardant material. ✧ Do not operate on the RBU if there is any damage or components loss. ✧ Do not touch the RBU, internal components and PCB board after wiring; otherwise electric shock may occur due to the present high DC voltage.
---	--

Note:

- ✧ Select appropriate moving and installing tools to ensure a safe and normal running of the RBU and avoid physical injury or death. For physical safety, the erector should take some mechanical protective measurements, such as wearing exposure shoes and working uniforms.
- ✧ Ensure to avoid physical shock or vibration during delivery and installation.
- ✧ Do not carry the RBU by its cover. The cover may fall off.
- ✧ Install away from children and other public places.
- ✧ The RBU can not meet the requirements of low voltage protection in IEC61800-5-1 if the sea level of installation site is above 2000m.
- ✧ Please use the RBU in proper environment.
- ✧ Avoid any conductive objects on the front cover, otherwise electrical shock may occur.
- ✧ Tighten up the screws when wiring, otherwise fire, leakage current may occur.

1.3.2 Commissioning and running

	<ul style="list-style-type: none"> ✧ Disconnect all power supplies applied to the RBU before the terminal wiring and wait for at least the designated time after disconnecting the power supply. ✧ Only qualified electricians are allowed to operate on the RBU. ✧ Inspect the wiring before running. ✧ Do not touch the terminals of control board when power on. ✧ Adjust and inspect the RBU only after the power indicator is totally off and the voltage between (+) and (-) is measured to be 0 by multimeter. ✧ Do not touch any internal components during the running. ✧ Damage to the inverter may occur if not follow correct application steps. ✧ Our company is not responsible for any inverter fault. Please install semiconductor fuses.
---	---

Note:

- ✧ Do not switch on or off the input power supply of the RBU frequently.
- ✧ Ensure correct setting of the RBU.

- ✧ Do not do any voltage test on the RBU, otherwise damage to the semiconductor components may occur.
- ✧ Fans or other cooling device are needed in multiple installations.
- ✧ Temperature and other protection are needed for RBU. Our company is not responsible for any heating damage to the regenerative resistor caused by the RBU fault.

1.3.3 Maintenance and replacement of components

	<ul style="list-style-type: none"> ✧ Only qualified electricians are allowed to perform the maintenance, inspection, and components replacement of the RBU. ✧ Disconnect all power supplies to the RBU before the terminal wiring. ✧ Take measures to avoid screws, cables and other conductive matters to fall into the RBU during maintenance and component replacement.
---	---

Note:

- ✧ Please select proper torque to tighten screws.
- ✧ Keep the RBU, parts and components away from combustible materials during maintenance and component replacement.
- ✧ Do not carry out any isolation and pressure test on the inverter and do not measure the control circuit of the RBU by megameter.

1.3.4 What to do after scrapping

	<ul style="list-style-type: none"> ✧ There are heavy metals in the inverter. Deal with it as industrial effluent.
---	--

2 Inspection

2.1 Unpacking inspection

Check as followings after receiving products:

1. Check that there are no damage and humidification to the package. If not, please contact with local agents or INVT offices.
2. Check the information on the type designation label on the outside of the package to verify that the drive is of the correct type. If not, please contact with local dealers or INVT offices.
3. Check that there are no signs of water in the package and no signs of damage or breach to the RBU. If not, please contact with local dealers or INVT offices.
4. Check the information on the type designation label on the outside of the package to verify that the name plate is of the correct type. If not, please contact with local dealers or INVT offices.

2.2 Application confirmation

Check as followings before the actual installation and usage:

1. Check that the ambient temperature of the RBU is below 40°C. If exceeds, derate 3% for every additional 1°C. Additionally, the RBU can not be used if the ambient temperature is above 50°C.
2. Check that the ambient temperature of the RBU in actual usage is above -10°C. If not, add heating facilities.
3. Check that the altitude of the actual usage site is below 1000m. If exceeds, derate 1% for every additional 100m.
4. Check that the humidity of the actual usage site is below 90% and condensation is not allowed. If not, add additional protection devices.
5. Check that the actual usage site is away from direct sunlight and foreign objects can not enter the RBU. If not, add additional protective measures.
6. Check that there is no conductive dust or flammable gas in the actual usage site. If not, add additional protection to the RBU.

2.3 Installation confirmation

Check as followings after the installation:

1. Check that the load range of the input and output cables meet the need of actual load.
2. Check correct setting of the RBU.
3. Check that the RBU is installed on non-flammable materials and the calorific accessories

(reactors and brake resistors) are away from flammable materials.
4. Check that all control cables and power cables are run separately and the routation complies with EMC requirement.
5. Check that all grounding systems are properly grounded according to the requirements of the inverter.
6. Check that the free space during installation is sufficient according to the instructions in user's manual.
7. Check that the external connection terminals are tightly fastened and the torque is appropriate.
8. Check that there are no screws, cables and other conductive items left in the inverter. If not, get them out.

3 Product overview

3.1 Comprehensive features

Technological feature	Instruction
Voltage range	AC 3PH 400V AC 3PH 660V
Brake torque	Continuously run with 100% of rated torque
AC power	400VAC/660VAC/C, 50/60Hz
AC voltage range	+10%~15%, the imbalance between phases less than 2%
AC frequency range	Less than 3Hz
Control mode	Current Control with 120°
AC power factor	Higher than 0.9
Overload capacity	60s with 150% of rated current
Operation mode	External terminal; Keyboard
Fault output	Relay output
Status display	LED Keypad
Analog output	Voltage (0~10V)
Overcurrent protection	330% of the rated current
Overload protection	60s with 150% of rated current
Overvoltage	DC:830V/1250V
Over-temperature	Temperature resistance detection
AC phase failure fault	AC phase loss
AC frequency failure fault	Fluctuating higher than 3Hz
Power light display	DC: higher than 50V

3.2 Product name and model

RBU100H-055-4
A B C D E F

Designation keys:

Designation key	Instruction
A	RBU: regenerative braking unit
B	1 means the technological version

Designation key	Instruction
C	00 are the spare codes
D	L: light-load H: heavy-load
E	Power code; 055 means 55kW
F	4: for 400V voltage degree 6: for 660V voltage degree

3.3 Rated specifications

The rated power of RBU100H is the motor power at 100% braking torque.

3.3.1 400V

Model	Rated power (kW)	Rated current at DC side(A)	Rated current at AC side(A)
RBU100H-022-4	22	37	30
RBU100H-030-4	30	51	40
RBU100H-045-4	45	77	60
RBU100H-055-4	55	96	75
RBU100H-090-4	90	150	120
RBU100H-110-4	110	183	145
RBU100H-132-4	132	220	176
RBU100H-160-4	160	267	213
RBU100H-200-4	200	333	266
RBU100H-250-4	250	417	330

3.3.2 660V



Model	Rated power (kW)	Rated current at DC side(A)	Rated current at AC side(A)
RBU100H-055-6	55	52	42
RBU100H-090-6	90	86	68
RBU100H-160-6	160	152	122
RBU100H-200-6	200	190	152
RBU100H-315-6	315	300	230
RBU100H-400-6	400	400	330

Note:

1. RBU 400V 22kW-45 kW has internal output reactor. RBU 400V 55kW-250kW/660V 55kW-400kW has standard output reactor.

2. Each RBU100H has 1 standard input reactor. Select the input reactor according to the rated parameters of the inverter.
3. The input filter is optional. Select the input filter according to the rated parameters of the inverter.
4. The fuse is optional. Configure the fuse at 1.5 times of the rated current of the RBU.

4 Installation Guidelines

	<ul style="list-style-type: none"> ◇ Only qualified electricians are allowed to carry out what described in this chapter. Please operate as the instructions in Safety Precautions. Ignoring these may cause physical injury or death or damage to the devices. ◇ Ensure the power supply of the RBU is disconnected during the operation. Wait for at least the time designated until the POWER indicator is off after the disconnection if the power supply is applied. It is recommended to use the multimeter to monitor that the DC bus voltage of the drive is under 36V. ◇ The installation and design of the RBU should be complied with the requirement of the local laws and regulations in the installation site. If the installation infringes the requirement, our company will exempt from any responsibility. Additionally, if users do not comply with the suggestion, some damage beyond the assured maintenance range may occur.
	<ul style="list-style-type: none"> ◇ Don not hold the front cover only during moving, otherwise the machine may fall.

4.1 Installation environment

The installation environment is the safeguard for a full performance and long-term working of the RBU.

Check the installation environment as followings:

Environment	Conditions
Installation site	Indoor
Environment temperature	<p>-10~+40℃</p> <p>It is not recommended to use the inverter if the ambient temperature is above 40℃.</p> <p>In order to improve the reliability of the device, do not use the RBU if the ambient temperature changes frequently.</p> <p>Please provide cooling fan or air conditioner to control the internal ambient temperature below the required one if the RBU is used in a close space such as in the control cabinet.</p> <p>When the temperature is too low, if the RBU needs to restart to run after a long stop, it is necessary to provide an external heating device to increase the internal temperature, otherwise damage to the devices may occur.</p>
Humidity	<p>RH≤90%</p> <p>No condensation is allowed.</p>

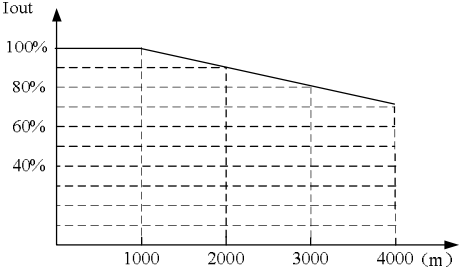
Environment	Conditions												
	The maximum relative humidity should be equal to or less than 60% in corrosive air.												
Storage temperature	-30~+60℃												
Running environment condition	The installation site should: keep away from the electromagnetic radiation source; keep away from contaminative air, such as corrosive gas, oil mist and flammable gas; ensure foreign objects, such as metal power, dust, oil, water can not enter into the inverter(do not install the inverter on the flammable materials such as wood); keep away from direct sunlight, oil mist, steam and vibration environment.												
Altitude	Below 1000m If the sea level is above 1000m, please derate 1% for every additional 100m.  <table border="1"> <caption>Altitude Derating Data</caption> <thead> <tr> <th>Altitude (m)</th> <th>I_{out} (%)</th> </tr> </thead> <tbody> <tr> <td>0</td> <td>100</td> </tr> <tr> <td>1000</td> <td>100</td> </tr> <tr> <td>2000</td> <td>90</td> </tr> <tr> <td>3000</td> <td>80</td> </tr> <tr> <td>4000</td> <td>70</td> </tr> </tbody> </table>	Altitude (m)	I _{out} (%)	0	100	1000	100	2000	90	3000	80	4000	70
Altitude (m)	I _{out} (%)												
0	100												
1000	100												
2000	90												
3000	80												
4000	70												
Vibration	$\leq 5.8\text{m/s}^2(0.6\text{g})$												
Installation direction	The RBU should be installed on an upright position to ensure sufficient cooling effect.												

Note:

- ◆ RBU100H should be installed in a clean and ventilated environment according to enclosure classification.
- ◆ Cooling air must be clean, free from corrosive materials and electrically conductive dust.

4.2 Installation direction

The RBU100H may be installed on the wall or in a cabinet.

The RBU100H must be installed in an upright position. Check the installation site according to the requirements below. Refer to chapter **Dimension Drawings** in the appendix for frame

details.

4.3 Installation steps

- (1) Mark the hole location. The location of the holes is shown in the dimension drawings in the appendix.
- (2) Fix the screws or bolts to the marked locations.
- (3) Position the drive onto the wall.
- (4) Tighten the screws in the wall securely.

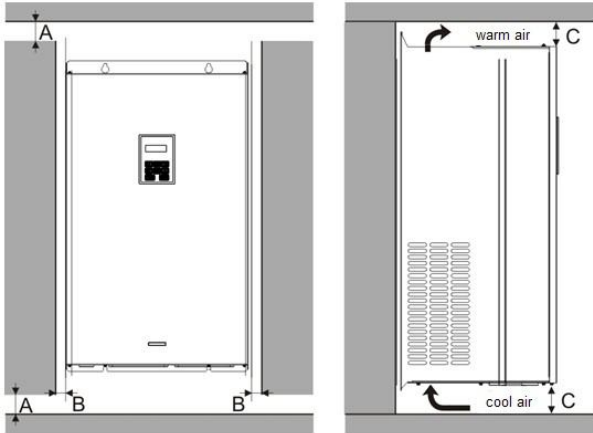

Figure 4-1 Installation space

Note: The minimum space of B and C is 100mm.

C Multiple installation

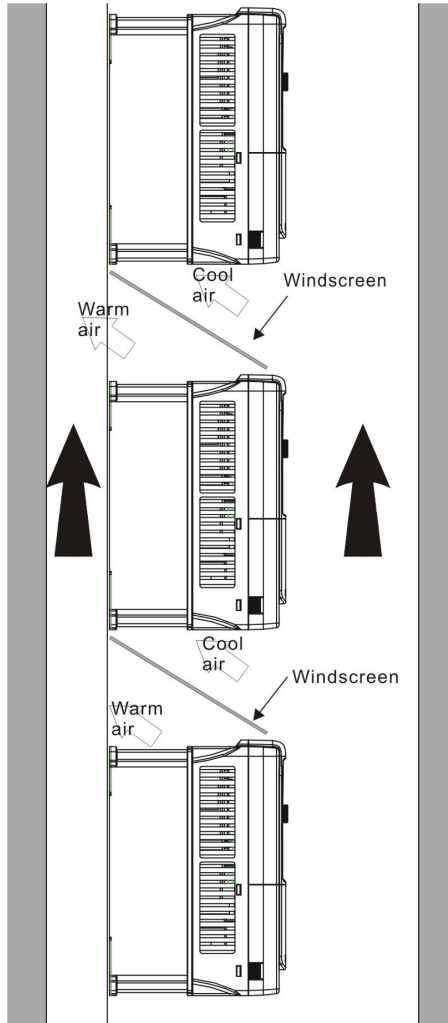

Figure 4-2 UP/DOWN installation

Note: Windscreen should be added in Vertical installation for avoiding mutual impact and insufficient cooling.

4.4 Terminals and function

4.1.1 Terminals of the main circuit

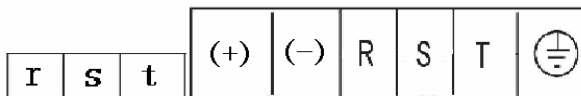





Figure 4-3 Terminals of the main circuit

Function:

Terminal	Function
r, s, t	Terminals of 3 phase AC input
(+), (-)	Input terminals of RBU
R, S, T	Terminals of external DC reactor
	Grounding terminal (PE)

The main circuit of RBU100H is very simple. Connect the “(+)” and “(-)” of RBU with the positive and negative pole of the inverter; connect the “R”, “S” and “T” of RBU to the power supply of the inverter; connect the “r”, “s” and “t” of RBU to the grid.

	<p>◇ It is necessary to use external reactor on RBU100H (the RBU of 400V 22-45kW has internal RBU). Corresponds the terminal of the reactor to the terminal of RBU, otherwise the damage to RBU and fire may occur.</p> <p>◇ Note the polarity of the RBU, otherwise the damage to RBU and fire may occur.</p>
	<p>◇ Ground the PE terminal of the RBU to avoid physical hurt.</p>

4.1.2 Terminals of the control circuit

AO	GND	S1	S2	S3	S4	COM	+24V	Y	ROA	ROB	ROC
----	-----	----	----	----	----	-----	------	---	-----	-----	-----

Figure 4-4 Terminals of the control circuit

Function:

Terminal	Function
S1~S4	<p>ON-OFF input terminal. Optical coupling isolation input terminal with +24V and COM.</p> <p>S1: Valid in terminal control. Automatic input.</p> <p>S2: Valid in terminal control. Automatic/Manual input.</p> <p>S3: Multi-function terminal</p> <p>S4: Multi-function terminal</p>
Y	<p>Open collector output terminal, the corresponding common ground terminal is COM.</p> <p>External voltage range: 0~24V</p> <p>Output current range: 0~50mA</p>
+24V	The inverter provides the power supply for users with a maximum output current of 150mA
COM	+24V common terminal
AO	Output range:0~10V

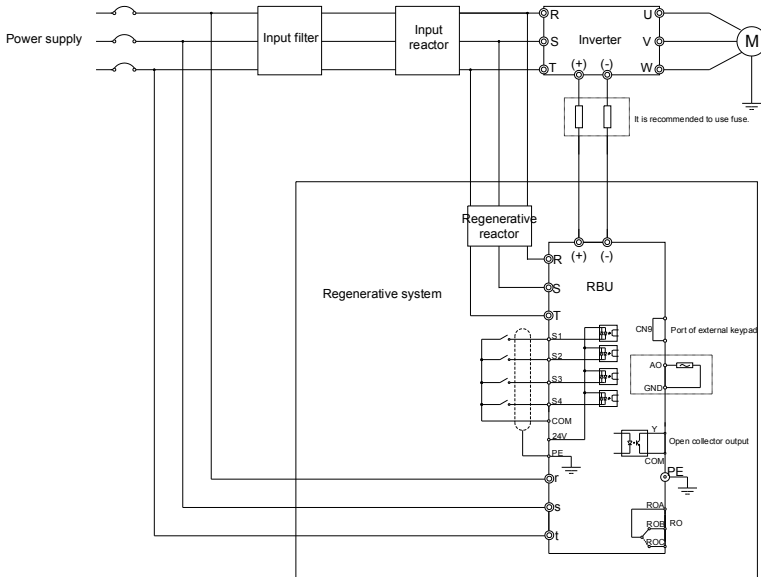

Figure 4-6 Standard wiring of RBU 400V 55kW-250kW/660V 55kW-400kW

Note:

1. RBU 400V 55kW-250kW/660V 55kW-400Kw has standard input/output reactor.
2. Input filter is optional.
3. The fuse is optional. Configure the fuse at 1.5 times of the rated current of the RBU.

4.6 Parallel connection**4.6.1 Parallel connection of RBU (M-S configuration)**

Steps:

1. Master setting:

- 1) P0.17=2;
- 2) Select P0.00=1 (terminal control);
- 3) Set as manual mode or automatic mode.

2. Slave setting:

- 1) Connect Y and COM of the master to S2 and COM of the slave;
- 2) Select P0.00=1 (terminal control);
- 3) Set as manual mode (S2 valid).

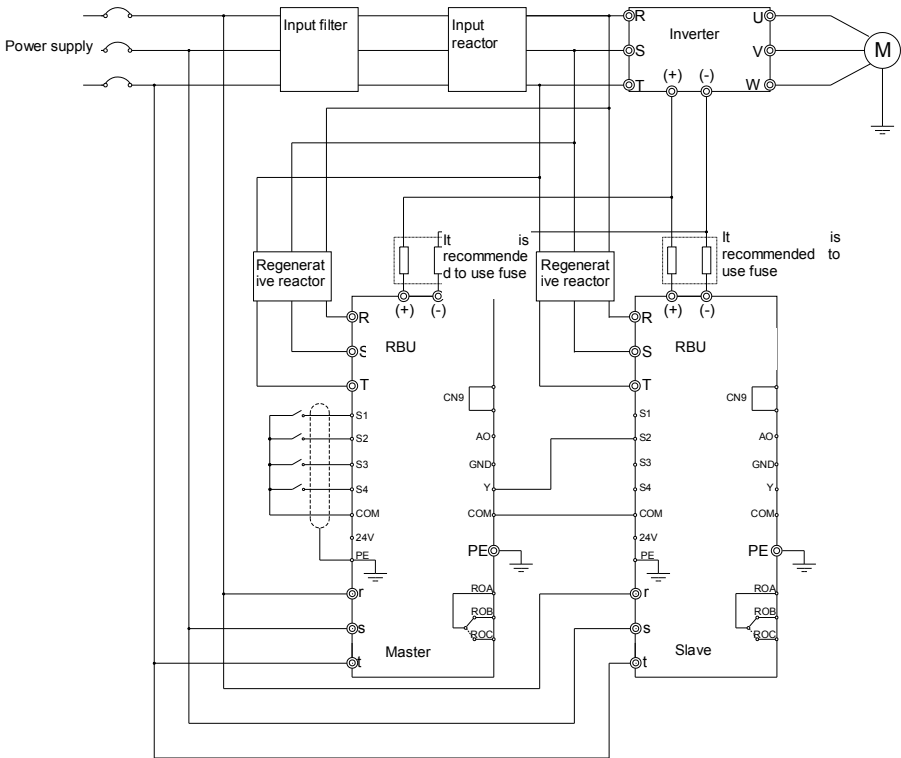

Figure 4-7 Parallel connection 1 of RBU

Connection instruction: make the first RBU as the master and others as the slave in parallel connection. Connect the Y and COM terminal of the first RBU to the S2 and COM terminal of the second one, third one and so on.

Note:

1. RBU 400V 22kW~45Kw has internal output reactor. RBU 400V 55kW~250kW/660V 55kW~400kW has standard output reactor.
2. Each RBU100H has 1 standard input reactor. Select the input reactor according to the rated parameters of the inverter.
3. The input filter is optional. Select the input filter according to the rated parameters of the inverter.
4. The fuse is optional. Configure the fuse at 1.5 times of the rated current of the RBU.
5. Derate 90% of the RBU100H in parallel connection.

4.6.2 Parallel connection of RBU (No master and slave)

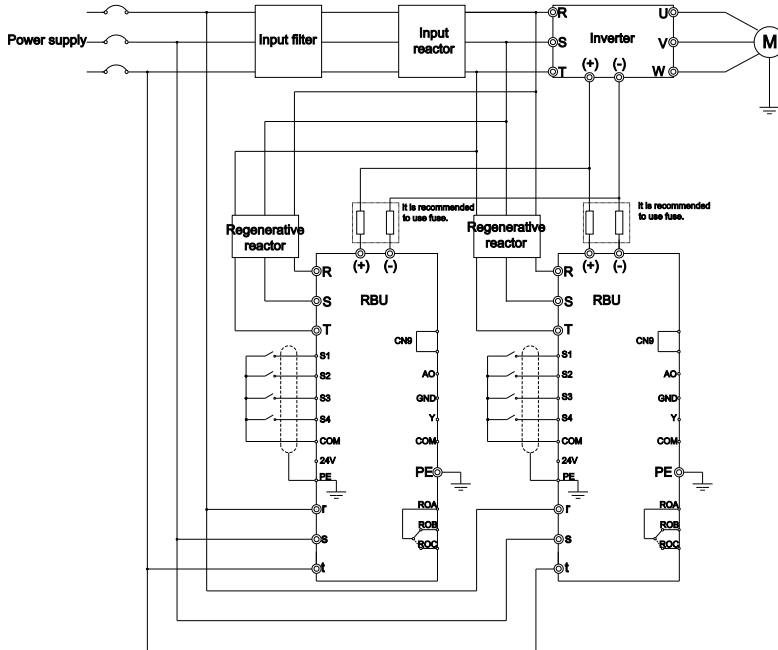

Figure 4-7 Parallel connection 2 of RBU

Note:

1. RBU 400V 22kW-45 kW has internal output reactor. RBU 400V 55kW-250kW/660V 55kW-400kW has standard output reactor.
2. Each RBU100H has 1 standard input reactor. Select the input reactor according to the rated parameters of the inverter.
3. The input filter is optional. Select the input filter according to the rated parameters of the inverter.
4. The fuse is optional. Configure the fuse at 1.5 times of the rated current of the RBU.
5. Derate 90% of the RBU100H in parallel connection.

5 Keypad Operation

5.1 Keypad

5.1.1 Keyboard diagram

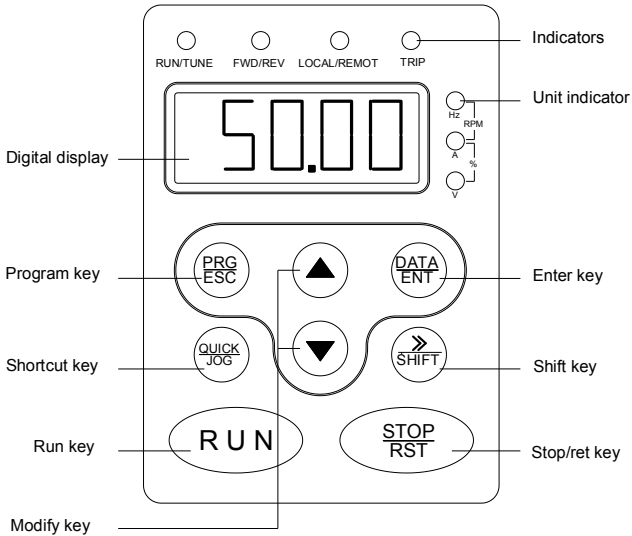



Figure 5-1 Keypad diagram



5.1.2 Buttons

Button	Name	Function
	Program Key	Enter or escape from the first level menu to delete the parameter quickly
	Enter Key	Progressively enter menu and confirm parameters.
	UP Increment Key	Progressively increase data or function codes.
	DOWN Decrement Key	Progressive decrease data or function codes.
	Shift Key	In parameter setting mode, press this button to select the bit to be modified. In other modes, cyclically displays parameters by right shift
	Run Key	Start to run the inverter in keypad control mode.

Button	Name	Function
	STOP/RST Key	In running status, restricted by P0.00, can be used to stop the inverter. When fault alarm, the button can be used to reset the inverter without any restriction.

5.1.3 Indicators

1) Function indicator light description:

Function indicator	Description
	Extinguished: stop status Flickering: parameter autotuning status Light on: operating status
	Extinguished: keypad control Flickering: terminal control Light on: communication control
	Extinguished: normal operation status Flickering: overload pre-warning status

2) Unit indicator light description:

Function indicator	Description
Hz	Frequency unit
A	Current unit
V	Voltage unit
RPM	Rotating speed unit
%	Percentage
	System temperature

3) Digital display:

5-digit LED, which can display all kinds of monitoring data and alarm codes such as reference frequency, output frequency and so on.

6 Function parameters

6.1 Function code

Code	Name	Detailed instruction	Default	Modify	No.
P0 group Basic function					
P0.00	Control mode	0~1 0: Keypad 1: Terminal: S1 valid: automatic operation S2 valid: manual operation	1	☉	0.
P0.01	Keypad control	0~1 0: Automatic operation 1: Manual operation	0	☉	1.
P0.02	Filter time	1~10	1	☉	2.
P0.03	Power loss protection threshold	0.5~30.0%	5.0%	○	3.
P0.04	Regenerative voltage	400.0~760.0V	650.0V	○	4.
P0.05	Hysteresis range of regenerative voltage	0.0~60.0V	12.0V	○	5.
P0.06	Regenerative stop time	0.1~10.0S	1.0S	○	6.
P0.07	Input frequency	0~1 0:50Hz 1:60Hz	0	☉	7.
P0.08	S3 function	1~15 3:Valid when connect S3 to COM Other reserved	3 (external fault)	☉	8.
P0.09	S4 function	1~15 2: Valid when connect S4 to COM Other reserved	2 (fault reset)	☉	9.
P0.10	Reserved		1	○	10.

Code	Name	Detailed instruction	Default	Modify	No.
P0.11	AO output	0~8 0: DC voltage(0~1000V) 1: Output current (0~200.0%) 2~8: Reserved	1	<input type="radio"/>	11.
P0.12	Lower limit of AO output	0.0%~100.0%	0.0%	<input type="radio"/>	12.
P0.13	Corresponding output of lower limit of AO	0.00V~10.00V	0.00V	<input type="radio"/>	13.
P0.14	Upper limit of AO output	0.0%~100.0%	100.0%	<input type="radio"/>	14.
P0.15	Corresponding output of upper limit of AO	0.00V~10.00V	10.00V	<input type="radio"/>	15.
P0.16	Running mode of the cooling fan	0~1 0:Operate after starting 1:Start when the temperature of the heat sink exceeds 45℃	1	<input type="radio"/>	16.
P0.17	Y switch output selection	0~15 0:No output	0	<input type="radio"/>	17.
P0.18	RO selection	1:Operation command valid 2:Regenerative output 3: Reserved 4:Fault output 5~15: Reserved	4(fault output)	<input type="radio"/>	18.
P0.19	UV protection	300.0~400.0V	380.0V	<input type="radio"/>	19.
P0.20	Fault reset times	0~3	0	<input checked="" type="radio"/>	20.
P0.21	Fault reset time	0.1~10.0S	3.0S	<input checked="" type="radio"/>	21.
P0.22	Phase loss protection	0~1 0: Invalid 1:Valid	1	<input checked="" type="radio"/>	22.
P0.23	Protection time of phase loss	0.5~10.0S	1.0S	<input checked="" type="radio"/>	23.

Code	Name	Detailed instruction	Default	Modify	No.
P0.24	Operation time	0~XXXXXH		●	24.
P0.25	Function parameters reset/fault history clear	0~2 0: No change 1: Reset 2: Fault history clear	0	◎	25.
P0.26	Software version			●	26.
P0.27	Previous three fault type	0~26 0: No fault 1: Reserved 2: Reserved 3: OUt3 4: Reserved 5: Reserved		●	27.
P0.28	Previous two fault type	6: OC3 7: Reserved 8: Reserved 9: OV3 10: UV 11: Reserved 12: OL2 13: Reserved 14: SPO 15: Reserved		●	28.
P0.29	Previous fault type	16: OH2		●	29.
P0.30	Current fault	17: EF 18: Reserved 19: ItE 20: Reserved 21: EEP 22: Reserved 23: Reserved 24: Reserved 25: CP 26: PEr		●	30.

Code	Name	Detailed instruction	Default	Modify	No.
P0.31	OC at current fault			●	31.
P0.32	DC voltage at current fault			●	32.
P0.33	Parameter lock	0~1 0: Null 1: Lock	0	○	33.
P1.00	User password	0~65535	*****	◎	34.

6.2 Detailed function

Function code	Name	Detailed instruction	Default
P0.00	Control mode	0~1 0: Keypad 1: Terminal : S1 valid: automatic operation S2 valid: manual operation	1
P0.01	Keypad control	0~1 0: Automatic operation 1: Manual operation	0

Automatic operation:

In automatic operation, the RBU detects the DC voltage and the operation stops.

The RBU works when DC voltage of the inverter-standard DC voltage $> P0.04$

The RBU stops when DC voltage of the inverter-standard DC voltage $< P0.05$

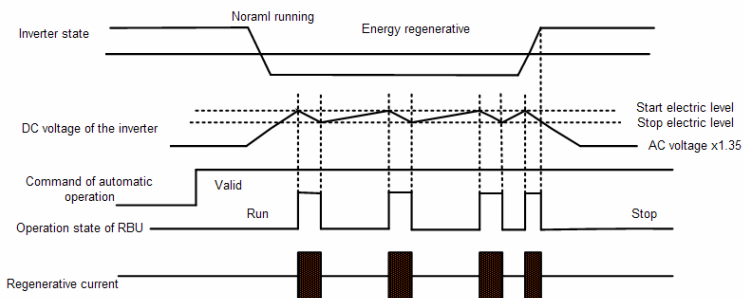

Manual operation:

RBU works when receiving the command.

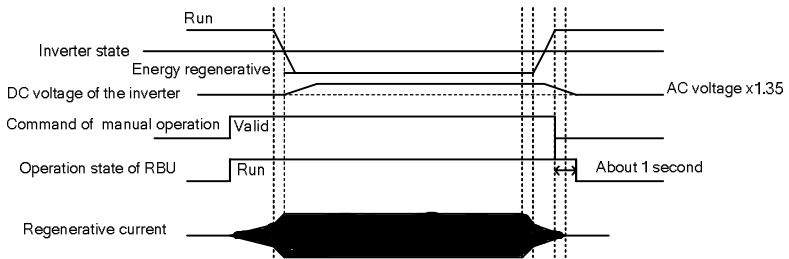

7 Fault tracking

Fault is indicated by LEDs. When FAULT indicator is on, the RBU is in an abnormal state. Use the information given in this chapter to find out the fault cause. If not, contact with the INVT office.

Fault code	Fault type	Possible cause	What to do
OU3	IGBT fault	<ol style="list-style-type: none"> 1. IGBT module fault. 2. The connection of the driving wires is not good. 3. Grounding is not properly. 	<ol style="list-style-type: none"> 1. Inspect external equipment and eliminate interference and press STOP/RST. 2. Ask for help
OC3	Over-current in running	<ol style="list-style-type: none"> 1. The RBU is abnormal. 2. The power of RBU is too low. 	<ol style="list-style-type: none"> 1. Check the input power 2. Select the RBU with a larger power 3. Ask for help
OV3	Over-voltage in running	<ol style="list-style-type: none"> 1. The input voltage is abnormal. 2. There is large energy feedback. 	<ol style="list-style-type: none"> 1. Check the input power 2. Check if the DEC time of the load is too short or the inverter starts during the rotation of the motor or it needs to increase the energy consumption components. 3. Ask for help
OL2	RBU overload	<ol style="list-style-type: none"> 1. Reset the rotating motor 2. The voltage of the power supply is too low. 3. The load is too heavy. 4. Close loop vector control, reverse direction of the code panel and long 	<ol style="list-style-type: none"> 1. Avoid the restarting after stopping. 2. Check the power of the supply line 3. Select an inverter with bigger power. 4. Select a proper motor 5. Ask for help

Fault code	Fault type	Possible cause	What to do
		low-speed operation	
SPO	Output phase loss	U,V,W phase loss input	<ol style="list-style-type: none"> 1. Check the output distribution 2. Ask for help
OH2	IGBT overheat	<ol style="list-style-type: none"> 1. Air duct jam or fan damage 2. Ambient temperature is too high. 	<ol style="list-style-type: none"> 1. Refer to the overcurrent solution 2. Redistribute dredge the wind channel or change the fan 3. Low the ambient temperature 4. Check and reconnect 5. Ask for help
EF	External fault	S3 external fault input terminals action	<ol style="list-style-type: none"> 1. Check the external device input 2. Ask for help
ItE	Current detection fault	The connection of the control board is not good	<ol style="list-style-type: none"> 1. Check the connector and repatch 2. Ask for help
EEP	EEPROM fault	<ol style="list-style-type: none"> 1. Error of controlling the write and read of the parameters 2. EEPROM damage 	<ol style="list-style-type: none"> 1. Press STOP/RST 2. Ask for help
CP	Control power fault	Auxiliary power supply damage	<ol style="list-style-type: none"> 1. Ask for help
PEr	Parameters error		



⚡ **Apply non-isolation circuit for the RBU. Disconnect (+) and (-) and ensure there is no voltage present before operation.**

8 Maintenance and hardware diagnostics

8.1 Maintenance interval

If installed in an appropriate environment, the RBU requires very little maintenance. The table lists the routine maintenance intervals recommended by INVT.

Checking		Item	Method	Criterion
Ambient environment		Check the ambient temperature, humidity and vibration and ensure there is no dust, gas, oil fog and water drop.	Visual examination and instrument test	Conforming to the manual
		Ensure there are no tools or other foreign or dangerous objects	Visual examination	There are no tools or dangerous objects.
Voltage		Ensure the main circuit and control circuit are normal.	Measurement by millimeter	Conforming to the manual
Main circuit	For public use	Ensure the screws are tightened up	Tighten up	NA
		Ensure there is no distortion, crackles, damage or color-changing caused by overheating and aging to the machine and insulator.	Visual examination	NA
	Ensure there is no dust and dirtiness	Visual examination	NA Note: if the color of the copper blocks change, it does not mean that there is something wrong with the features.	
	The lead of the conductors	Ensure that there is no distortion or color-changing of the conductors caused by overheating.	Visual examination	NA
		Ensure that there are no crackles or color-changing of the protective layers.	Visual examination	NA
	Terminals seat	Ensure that there is no damage	Visual examination	NA
	Resistors	Ensure whether there is	Smelling and	NA

Checking		Item	Method	Criterion
		replacement and splitting caused by overheating.	visual examination	
		Ensure that there is no offline.	Visual examination or remove one ending to coagulate or measure with multimeters	The resistors are in $\pm 10\%$ of the standard value.
Control circuit	PCB and plugs	Ensure there is no loose screws and contactors.	Fasten up	NA
		Ensure there is no smelling and color-changing.	Smelling and visual examination	NA
		Ensure there are no crackles, damage distortion and rust.	Visual examination	NA
		Ensure there is no weeping and distortion to the capacitors.	Visual examination or estimate the usage time according to the maintenance information	NA
Cooling system	Cooling fan	Estimate whether there is abnormal noise and vibration.	Hearing and Visual examination or rotate with hand	Stable rotation
		Estimate there is no losses screw.	Tighten up	NA
		Ensure there is no color-changing caused by overheating.	Visual examination or	NA

Checking		Item	Method	Criterion
			according to the maintenance information	
	Ventilating duct	Ensure whether there is stuff or foreign objection in the cooling fan, air vent.	Visual examination	NA

Consult the local INVT Service representative for more details on the maintenance. Visit the official website of INVT: <http://www.invt.com.cn> and select Inverter Services – Maintenance and Field Services.

8.2 Cooling fan

The RBU's cooling fan has a minimum life span of 25,000 operating hours. The actual life span depends on the inverter usage and ambient temperature.

Fan failure can be predicted by the increasing noise from the fan bearings. If the RBU is operated in a critical part of a process, fan replacement is recommended once these symptoms appear. Replacement fans are available from INVT.

8.2.1 Replacing the cooling fan

	<p>⚠ Read and follow the instructions in chapter Safety Precautions. Ignoring the instructions would cause physical injury or death, or damage to the equipment.</p>
---	---

1. Stop and disconnect the power supply and wait for at least the time designated on the RBU.
2. Lever the fan holder off the drive frame with a screwdriver and lift the hinged fan holder slightly upward from its front edge.
3. Free the fan cable from the clip.
4. Disconnect the fan cable.
5. Remove the fan holder from the hinges.
6. Install the new fan holder including the fan in reverse order.
7. Restore power.

8.3 Capacitors

8.3.1 Reforming the capacitors

The DC bus capacitors must be reformed according to the operation instruction if the inverter has been stored for a long time. The storing time is counted from the producing date other than the delivery data which has been marked in the serial number of the inverter.

Time	Operational principle
Storing time less than 1 year	Operation without charging
Storing time 1-2 years	Connect with the power for 1 hour before first ON command
Storing time 2-3 years	Use power surge to charge for the inverter <ul style="list-style-type: none"> • Add 25% rated voltage for 30 minutes • Add 50% rated voltage for 30 minutes • Add 75% rated voltage for 30 minutes • Add 100% rated voltage for 30 minutes
Storing time more than 3 years	Use power surge to charge for the inverter <ul style="list-style-type: none"> • Add 25% rated voltage for 2 hours • Add 50% rated voltage for 2 hours • Add 75% rated voltage for 2 hours • Add 100% rated voltage for 2 hours

The method of using power surge to charge for the inverter:

The right selection of Power surge depends on the supply power of the inverter. Single phase 230V AC/2A power surge applied to the inverter with single/three-phase 230V AC as its input voltage. The inverter with single/three-phase 230V AC as its input voltage can apply Single phase 230V AC/2A power surge. All DC bus capacitors charge at the same time because there is one rectifier.

High-voltage inverter needs enough voltage (for example, 400V) during charging. The small capacitor power (2A is enough) can be used because the capacitor nearly does not need current when charging.

The operation method of inverter charging through resistors (LEDs):

The charging time is at least 60 minutes if charge the DC bus capacitor directly through supply power. This operation is available on normal temperature and no-load condition and the resistor should be serially connected in the 3-phase circuits of the power supply:

400V driven device: 1k/100W resistor. LED of 100W can be used when the power voltage is no more than 400V. But if used, the light may be off or weak during charging.

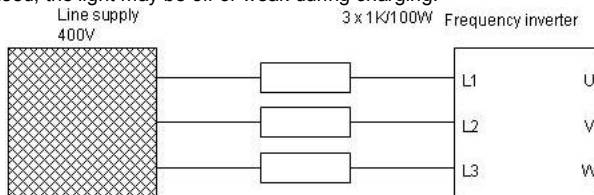

Figure 8-1 Illustration of the driven device 400V

8.3.2 Change electrolytic capacitors



✧ **Read and follow the instructions in chapter *Safety Precautions*. Ignoring the instructions may cause physical injury or death, or damage to the equipment.**

Change electrolytic capacitors if the working hours of electrolytic capacitors in the inverter are above 35000. Please contact with the local INVT offices or dial our national service hotline (400-700-9997) for detailed operation.

8.4 Power cables



✧ **Read and follow the instructions in chapter *Safety Precautions*. Ignoring the instructions may cause physical injury or death, or damage to the equipment.**

1. Stop the drive and disconnect it from the power line. Wait for at least the time designated on the RBU.
2. Check the tightness of the power cable connections.
3. Restore power.

9 Dimension and size

9.1 Dimension of the keypad

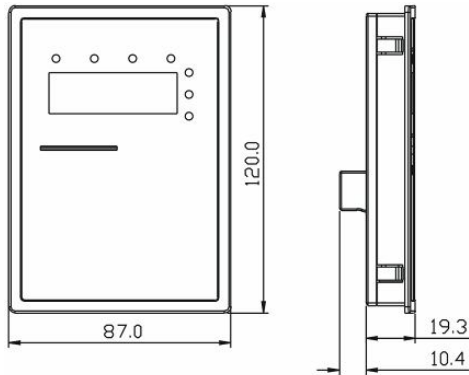

Figure 9-1 Dimension of the external keypad (big)

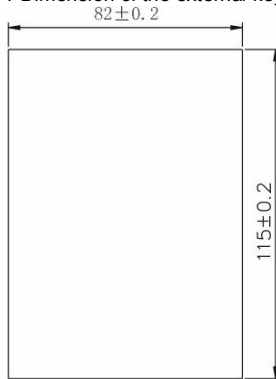

Figure 9-2 Hole dimension of the external keypad (big)

9.2 External dimension of RBU

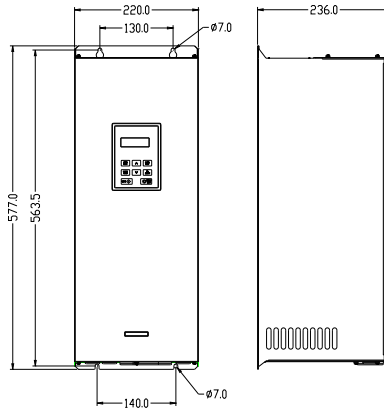

Figure 1-2 The external and installation dimension of RBU

Voltage degree	Model	W2(mm)	W3(mm)	H2(mm)	W1(mm)	H1(mm)	D(mm)	Installation hole (mm)
		Installation dimension			External dimension			
400V	22-45kW	130	140	563.5	220	577	236	7
	55-132kW	130	140	563.5	320	577	261	7
	160-250kW	250	250	732	440	750	326.2	9
660V	55-160kW	130	140	563.5	320	577	261	7
	200-400kW	250	250	732	440	750	326.2	9